



Transport Refrigeration

# Transport Refrigeration



# Transport Refrigeration

Daikin	2
Cold Chain Expertise	
From production to delivery	3
Vision 2050	4
Product Portfolio	5
Selection tool for box size	7

## Van Direct-Drive 8

## Invisible Direct-Drive 9

- SFZ007 | SFZ008 | SFZ009 | SFZ009 Multi 9

## Zero Direct-Drive 11

- Z200 | Z250 | Z350 | Z380 11

## Zero Direct-Drive Multi-Temp 13

- Z380 Multi 13

## Van Electric 14

## Invisible Electric 15

- SFZ008e | SFZ009e | SFZ009e Multi 15

## Zero Electric 17

- Z120b 17

## Electric Power Supply 18

## Zero Electric 19

- Z200e | Z250e | Z350e | Z350e Multi 19

## Light Truck 22

## SFZ 23

- SFZ238 | SFZ248 23

## SFZ Multi-Temp 25

- SFZ238 Multi | SFZ248 Multi 25

## Truck 26

## Uno 27

- U600 | U800 | U1000 28

## Uno 29

- U800 Multi | U1000 Multi 30

## Trailer 31

## Exigo 32

- E1500 32

## Exigo Accessories 33

- Solar Panel 34
- Datalogger 34

## Service Network 35

# Daikin

Air is essential to our existence, and our role in protecting it continues to expand.

"Aiming for sustainable growth and a sustainable society through technological strength and outstanding human resources"

- Masanori Togawa, President and CEO, Daikin Industries, Ltd.

Since 1924, we have devoted ourselves with unbridled passion to overcome the ever-evolving challenges of air to become the leading manufacturer of heating, ventilation, air conditioning and refrigeration equipment. Leveraging our innovative technology, we deliver outstanding products and system solutions to provide comfortable and sustainable environments for all people and goods in all regions of the world. This is, and always will be, the Daikin mission.

## Innovation means continuous improvement

We believe that there is always room for improvement, and this mindset is the driving force behind everything that we do at Daikin. From small advances in the production process, to major design breakthroughs that result in substantial energy savings, we aim to inspire technological change. With our regional development centres and global network of manufacturing and logistics facilities, we are serving the full breadth of HVACR needs of the world.

## Our Promise

For forward thinking consumers and businesses, Daikin is the all-inclusive partner, ensuring your peace of mind.

For our professional customers, our brand promise is

**Reliability – Sustainability – Efficiency.**



# Cold Chain Expertise

## From production to delivery

### Reshaping the future of cold chain supply

Combining refrigeration expertise with innovative technology, Daikin's comprehensive product portfolio delivers integrated temperature control solutions that improve quality and safety through every link in the distribution process from point of origin to the final consumer.

Our range of products and services provide the flexibility to meet diverse customer needs across a range of applications, during production, storage, retail and transit. Energy-efficient technologies with low-GWP refrigerants provide reliable and cost-effective operation, safeguarding perishable supplies, whatever the climate, while protecting the environment. We will leverage our strengths to cover the entire cold chain.

### COVERING THE ENTIRE COLD CHAIN

INDUSTRIAL-COMMERCIAL-TRANSPORT REFRIGERATION

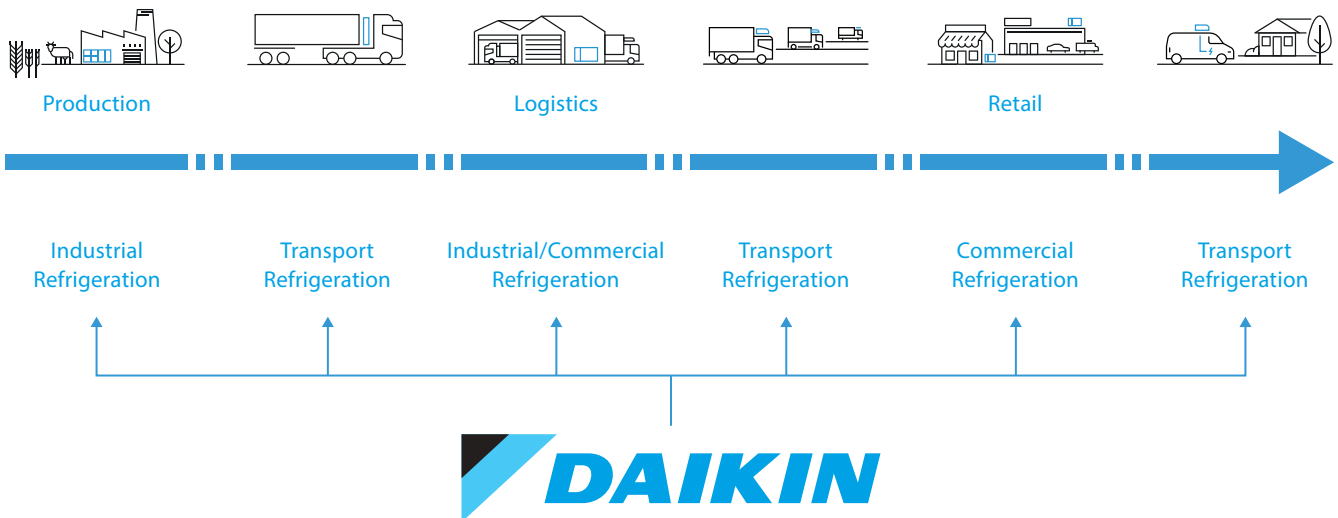

# Vision 2050

## Daikin Environmental Policy

Adopted in 2015, the Paris Agreement contains a target for the latter half of this century of reducing greenhouse gas emissions to net zero and limiting global warming by less than 2°C compared to pre-industrial levels. In the spirit of the Paris Agreement, Daikin has formulated Environmental Vision 2050, with a target of reducing greenhouse gas emissions to net zero by 2050. We have established a reduction target for 2030 and incorporated this into our efforts under the Fusion 25 Strategic Management Plan.

## Our Vision 2050

We will effectively eliminate the greenhouse gas emissions generated throughout the entire lifecycle of our products by 2050. Furthermore, we are committed to creating solutions that link society and customers as we work with stakeholders to reduce greenhouse gas emissions to net-zero. Using IoT and open innovation, we will meet the world's needs for air solutions by providing safe and healthy air environments while at the same time contributing to solving global environmental problems.

## Refrigeration Medium-Term Outlook

In our Cold Chain business, we are moving towards low-GWP and HFC-free natural refrigerants, while ensuring the correct safety standards are established in our markets. We maintain continuous focus on reducing the energy consumption of all our products. In the Transport Refrigeration industry, we will strive to lead the shift towards electrification and phasing-down of the reliance on combustion engine technologies.

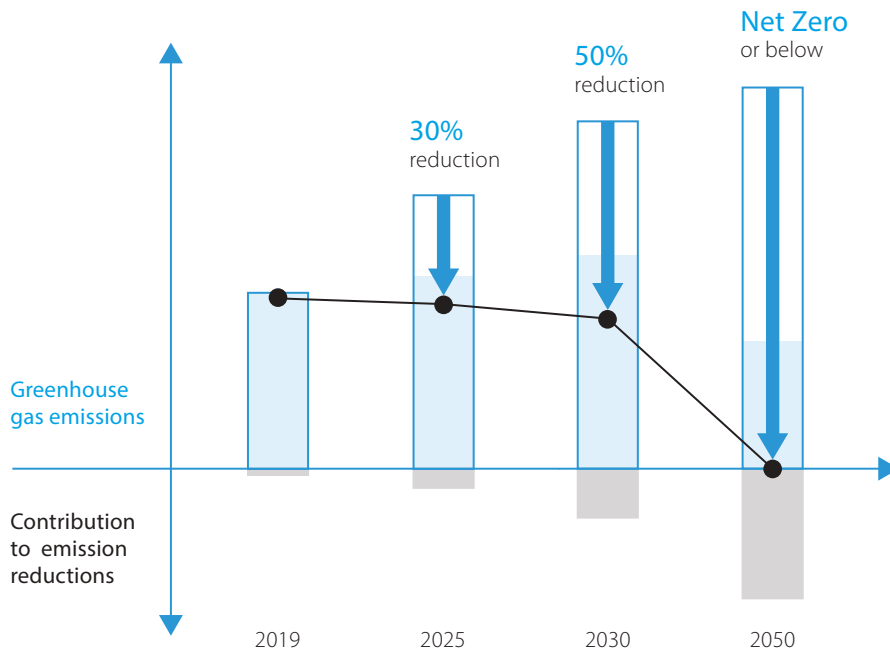

### Products

- Energy efficient products
- Lower global warming refrigerants
- Entire product lifecycle

### Solutions

- Energy management systems
- Energy services









### Carbon Offset

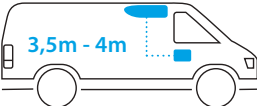
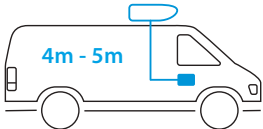
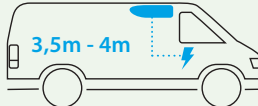
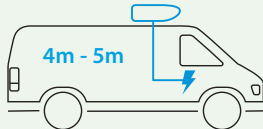





- Refrigerant recovery and recycle
- Renewable energy use
- Protecting forests
- And more...

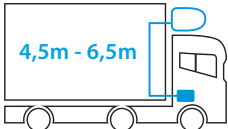
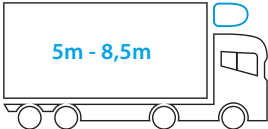
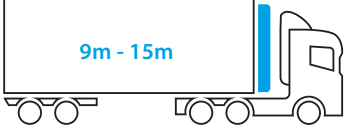

# Product Portfolio

Our transport refrigeration unit range offers reliable and efficient solutions for a wide range of applications and vehicle types. Each unit is designed to minimize your total cost of ownership, configured to your exact needs, manufactured to Daikin's rigorous quality standards, and supported with a service network available 24/7.

Van			
Direct-Drive		Electric 	
Invisible Direct-Drive	Zero Direct-Drive	Invisible Electric	Zero Electric
			
			
SFZ007 SFZ008 SFZ009	Z200 Z250 Z350 Z380	SFZ008e SFZ009e	Z120b Z200e Z250e Z350e
			
SFZ009 Multi	Z380 Multi	SFZ009e Multi	Z350e Multi

Light Truck	Truck	Trailer
SFZ	Uno	Exigo
		
		
SFZ238 SFZ248 SFZ268	U600 U800 U1000	E1500
		
SFZ238 Multi SFZ248 Multi SFZ268 Multi	U800 Multi U1000 Multi	

# Selection tool for box size

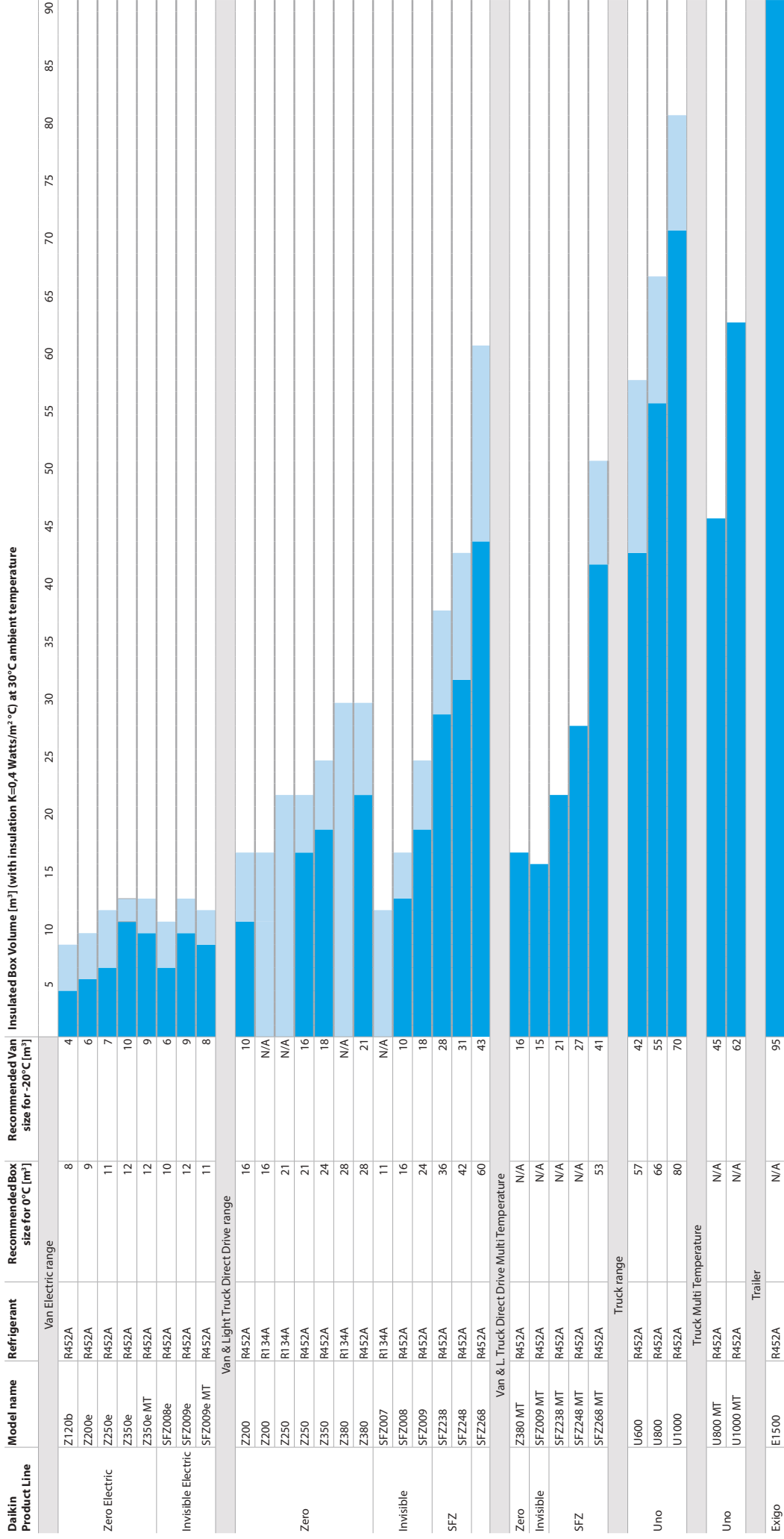

Note: This selection table is intended as a guide. It has been compiled using experience acquired in normal utilization of our equipment in transport and distribution. Conformity to these recommendations should guarantee your total satisfaction.

■ Frozen applications

■ Chilled applications

# Van Direct-Drive





## Invisible Direct-Drive

### SFZ007 | SFZ008 | SFZ009 | SFZ009 Multi

Our Invisible range is designed for discreet and efficient transportation of refrigerated products in vans. These units are installed underneath the vehicle chassis, completely invisible from the outside, preserving the aesthetics, original height and aerodynamics of the vehicle, while reducing bodywork. SFZ007, SFZ008 and SFZ009 offer varying refrigeration capacities and volume ratings tuned for different applications. SFZ009 Multi features dual evaporators to enable products with different temperature requirements to be transported in two separate zones.

The Invisible range, with its ultra-thin dimensions make it the ideal choice for customers who need a space-saving solution. A driver-friendly interface in the cabin allows real-time monitoring and control of the unit performance to ensure the cargo is maintained at precisely the right temperature throughout the trip.

#### Key Features:

- Multiple temperature zones in the same vehicle (Multi model only)
- Powered by direct-drive on engine, electric stand-by
- Vehicle access to tight underground areas
- Under-chassis mounting preserves vehicle aesthetics and aerodynamics
- Invisible from the outside
- Low noise
- User-friendly cabin driver interface
- Telematics-compatible
- 2-year standard warranty



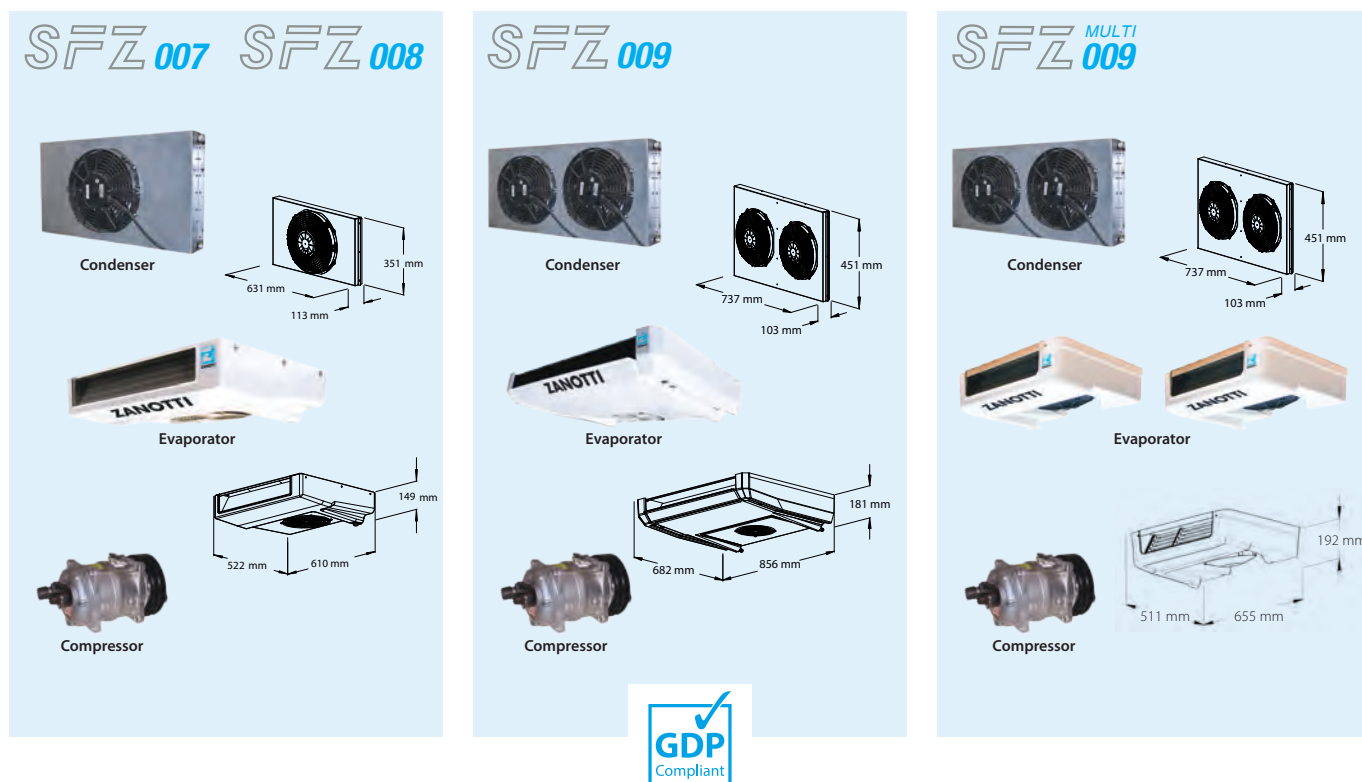

		SFZ007	SFZ008	SFZ009	SFZ009 Multi				
<b>General</b>									
Refrigerant		R134a		R452A					
Refrigerant quantity	kg	1.4	1.4	1.4	2.8				
Road compressor		QP13/UPF120	QP13/UPF120	QP16/UPF170	QP16/UPF170				
<b>System net cooling capacity under ATP conditions (30°C ambient temperature)</b>									
	°C	0°C	-20°C	0°C	-20°C	0°C	-20°C	0°C	-20°C
Road mode	W	1540	N/A	2010	1050	3160	1830	3175	1320
Stand-by mode	W	1115	N/A	1260	735	2030	1125	1975	875
Redommended body volume	m <sup>3</sup>	11	N/A	16	10	24	18	N/A	15
<b>Heating capacity</b>									
Road mode	W	N/A	1890	2790	2640				
Stand-by mode	W	N/A	1380	1630	1580				
<b>Airflow rate</b>									
Airflow rate at 100kPa static pressure	m <sup>3</sup> /h	786	786	1062	2x 620				
<b>Dimensions (LxWxH)</b>									
Condensing unit	mm	351x631x113	351x631x113	451x737x103	451x737x103				
Evaporator	mm	522x610x149	522x610x149	682x856x181	(2x) 511x655x192				
<b>Weight</b>									
Condenser without electric stand-by	kg	25	38	45	45				
Condenser with electric stand-by	kg	50	65	75	75				
Evaporator	kg	10	14	20,5	2x 10,2				

These products contain fluorinated greenhouse gases (R134a GWP=1430 / R452A GWP=2140,5).

Stand-by voltages available: 230/1/50 or 400/3/50

Vehicle voltages available: 12VDC or 24VDC



## Zero Direct-Drive

### Z200 | Z250 | Z350 | Z380

The Zero range meets the needs of the distribution industry by offering the utmost flexibility in the temperature management of refrigerated products. The extensive direct-drive Zero line-up including Z200, Z250, Z350, and Z380 is designed to meet a wide range of applications in light commercial vehicles.

#### Key Features:

- Proven reliability and performance
- Powered by direct-drive on engine, electric stand-by
- Easy to install and service with removable side panels
- Configurable for a wide range of refrigerated applications in light commercial vehicles
- Low noise
- User-friendly cabin driver interface
- Reduced refrigerant charge and maintenance costs
- Telematics-compatible
- 2-year standard warranty

All Zero models provide easy installation and serviceability. The condensing unit can be mounted on the roof or the front wall of the box, and the ultra-thin evaporator installed in the cargo compartment maximizes cargo volume. A driver-friendly interface in the cabin allows real-time monitoring and control of unit performance to ensure goods are maintained at precisely the right temperature throughout the trip. Our Zero units are setting new standards with their attractive design.



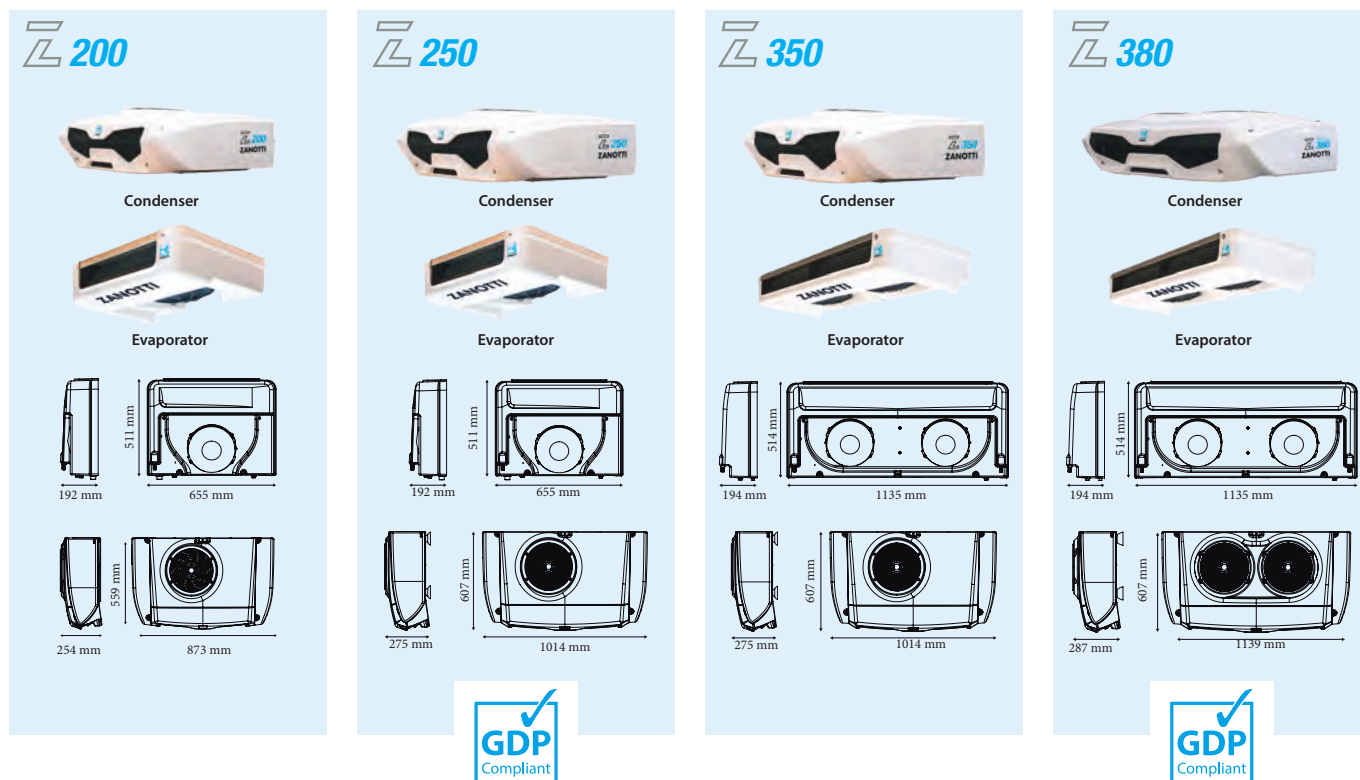

		Z200	Z250	Z380	Z200	Z250	Z350	Z380							
<b>General</b>															
Refrigerant		R134a			R452A										
Refrigerant quantity	kg	1.34	1.45	2.1	1.4	1.65	1.7	1.9							
Road Compressor		QP15/UPF150			QP13/UPF120		QP15/UPF150								
<b>System net cooling capacity under ATP conditions (30°C ambient temperature)</b>															
	°C	0°C	0°C	-20°C	0°C	-20°C	0°C	-20°C	0°C	-20°C	0°C	-20°C	0°C	-20°C	
Road mode	W	1750	N/A	2100	N/A	2920	N/A	2240	860	2680	1470	3350	1840	3800	2020
Stand-by mode	W	850	N/A	1190	N/A	2450	N/A	1400	630	2120	820	2240	890	2450	970
Recommended body volume	m <sup>3</sup>	16	N/A	21	N/A	28	N/A	16	10	21	16	24	18	28	21
<b>Heating capacity</b>															
Road mode	W	1750	1930	2620	2100	2500	3100	3300							
Stand-by mode	W	N/A	1020	1710	1300	1900	2000	2200							
<b>Airflow rate</b>															
Airflow rate at 100kPa static pressure	m <sup>3</sup> /h	622	650	1870	622	650	1300	1870							
<b>Dimensions (LxWxH)</b>															
Condensing unit	mm	559x873x254	607x1014x275	607x1139x287	559x873x254	607x1014x275	607x1014x275	607x1139x287							
Evaporator unit	mm	511x655x192	511x655x192	514x1135x194	511x655x192	511x655x192	514x1135x194	514x1135x194							
<b>Weight</b>															
Condenser without electric stand-by	kg	28	34	40	30	36	36	42							
Condenser with electric stand-by	kg	54	70	78	56	72	72	80							
Evaporator	kg	9	9	18	10,2	10,5	19,6	19,6							

These products contain fluorinated greenhouse gases (R134a GWP=1430 / R452A GWP=2140,5).

Stand-by voltages available: 230/1/50 or 400/3/50

Vehicle voltages available: 12VDC

# Zero Direct-Drive Multi-Temp

## Z380 Multi

Z380 Multi and Z380 Multi (Narrow Evap) models are designed to meet the modern needs of low environmental impact refrigeration for light commercial vehicles. These units feature additional evaporators to enable transport of products with different temperature requirements in separate zones, available in multiple configurations to adapt to a wide range of applications.

All Zero models provide easy installation and serviceability. The condensing unit can be mounted on the roof or the front wall of the box, and the ultra-thin evaporator installed in the cargo compartment maximizes cargo volume. A driver-friendly interface in the cabin allows real-time monitoring and control of unit performance to ensure goods are maintained at precisely the right temperature throughout the trip. Our Zero units are setting new standards with their attractive design.



### Key Features:

- Multiple temperature zones in the same vehicle
- Proven reliability and performance
- Powered by direct-drive on engine, electric stand-by
- Easy to install and service with removable side panels
- Configurable for a wide range of refrigerated applications in light commercial vehicles
- Low noise
- User-friendly cabin driver interface
- Reduced refrigerant charge and maintenance costs
- Telematics-compatible
- 2-year standard warranty

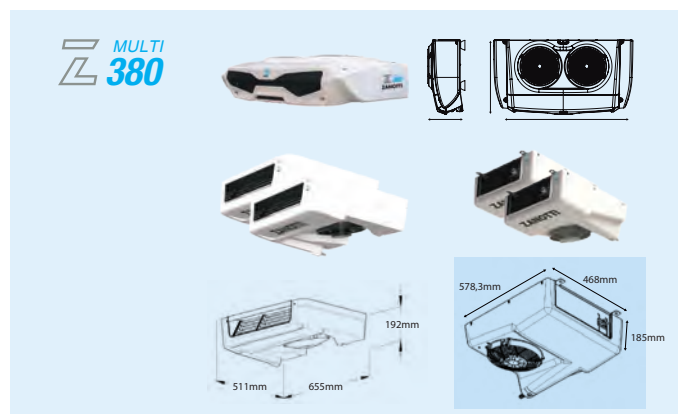

	Z380 Multi			Z380 Multi (Narrow Evap)		
<b>General</b>						
Refrigerant		R452A				
Refrigerant quantity	kg	1.7				
<b>System net cooling capacity under ATP conditions (30°C ambient temperature)</b>						
	°C	0°C	-20°C	0°C	-20°C	
Road mode	W	3256	1655	3250	1310	
Stand-by mode	W	2030	645	2420	1030	
Recommended body volume	m <sup>3</sup>	N/A	16	N/A	N/A	
<b>Heating capacity</b>						
Road mode	W	3010			2630	
Stand-by mode	W	1770			1520	
<b>Airflow rate</b>						
Airflow rate at 100kPa static pressure	m <sup>3</sup> /h	2x 620			2x 830	
<b>Dimensions</b>						
Condensing unit	mm	607x1139x287			607x1139x287	
Evaporator unit	mm	(2) 511x655x192			N/A	
<b>Weight</b>						
Condenser without electric stand-by	kg	42			42	
Condenser with electric stand-by	kg	80			80	
Evaporator	kg	2x 10,2			2x 16	
<b>Road compressor</b>						
Displacement	cc	146			146	

These products contain fluorinated greenhouse gases (R452A GWP=2140,5).

Stand-by voltages available: 230/1/50 or 400/3/50

Vehicle voltages available: 12VDC

# Van Electric





## Invisible Electric

### SFZ008e | SFZ009e | SFZ009e Multi

The Invisible Electric range is designed for discreet and efficient transportation of refrigerated products in vans on electric power, both on road and during stand-by. A highly reliable battery-inverter package supplies the power, making the Invisible Electric an ideal choice for full-electric, hybrid, or conventional vehicles.

These units are installed underneath the vehicle chassis, completely invisible from the outside, preserving the aesthetics, original height and aerodynamics of the vehicle, while reducing bodywork. SFZ009e offers varying refrigeration capacities and volume ratings tuned for different applications. SFZ009e Multi features dual evaporators to enable products with different temperature requirements to be transported in two separate zones.

#### Key Features:

- Zero emissions
- Powered by reliable battery-inverter pack on road, chargeable on electric grid
- Compatible with full-electric, hybrid or conventional vehicles
- Multiple temperature zones in the same vehicle (Multi model only)
- Vehicle access to tight underground areas
- Under-chassis mounting preserves vehicle aesthetics and aerodynamics
- Invisible from the outside
- Low noise
- User-friendly cabin driver interface
- Telematics-compatible
- 2-year standard warranty

The Invisible range, with its ultra-thin dimensions make it the ideal choice for customers who need a space-saving solution. A driver-friendly interface in the cabin allows real-time monitoring and control of the unit performance to ensure the cargo is maintained at precisely the right temperature throughout the trip.



Position of the unit on the vehicle.



Installation of the SFZ 009e condenser in the back of the vehicle.

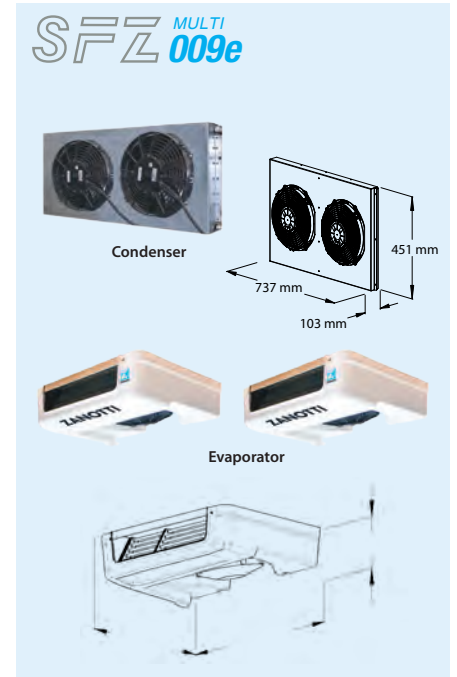
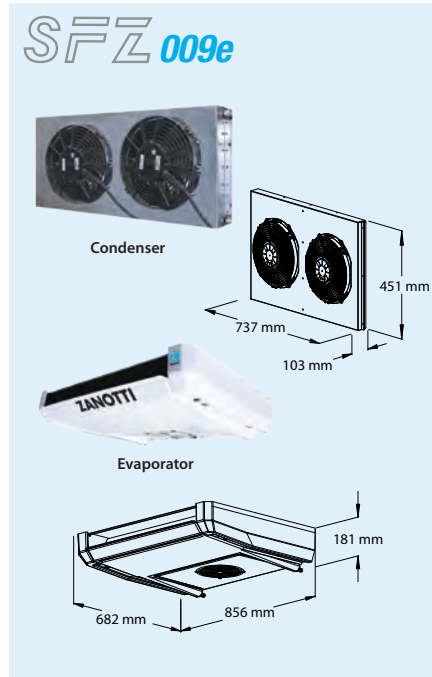
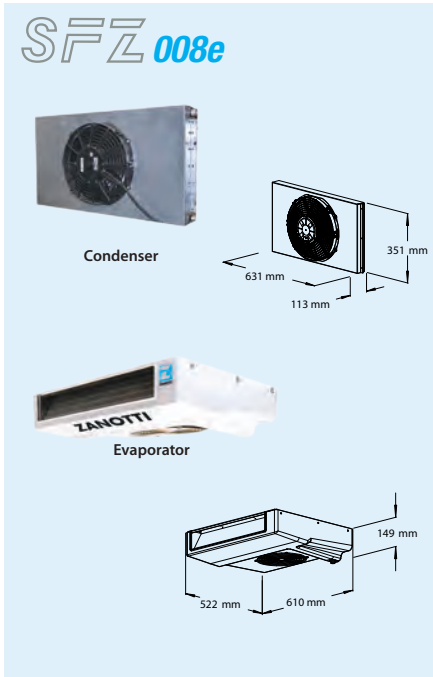

		SFZ008e	SFZ009e	SFZ009e Multi			
<b>General</b>							
Refrigerant			R452A				
Refrigerant quantity		1.4	1.4	2.8			
<b>System net cooling capacity under ATP conditions (30°C ambient temperature)</b>							
	°C	0°C	-20°C	0°C	-20°C	0°C	-20°C
Battery mode	W	1275	710	2340	1145	1975	875
Recomanded body volume	m <sup>3</sup>	10	6	12	9	11	8
<b>Heating capacity</b>							
Battery mode	W	1380		1650		1580	
<b>Airflow rate</b>							
Airflow rate at 100kPa static pressure	m <sup>3</sup> /h	786		1062		2x 620	
<b>Weight</b>							
Condenser with electric stand-by	kg	65		75		75	
Evaporator	kg	14		20,5		2x 10,2	
<b>Max current</b>							
	A	119		165		170	

These products contain fluorinated greenhouse gases (R452A GWP=2140,5).

Stand-by voltages available: 230/1/50 or 400/3/50

Vehicle voltages available: 12VDC or 24VDC

# Zero Electric

## Z120b

Z120b is powered by the vehicle battery, with minimal environmental impact and maximum cooling effectiveness ideal for refrigerated transport in vans. The unit can be installed quickly without any mechanical couplings with the vehicle engine, which also minimises power draw and thus emissions.

All Zero models provide easy installation and serviceability. The condensing unit can be mounted on the roof or the front wall of the box, and the ultra-thin evaporator installed in the cargo compartment maximizes cargo volume. A driver-friendly interface in the cabin allows real-time monitoring and control of unit performance to ensure goods are maintained at precisely the right temperature throughout the trip.



### Key Features:

- Low emissions
- Proven reliability and performance
- Powered by vehicle battery on engine, electric stand-by
- Compatible with full-electric, hybrid or conventional vehicles
- Easy to install and service with removable side panels
- Low noise
- User-friendly cabin driver interface
- Reduced refrigerant charge and maintenance costs
- Telematics-compatible
- 2-year standard warranty, extendable up to 5 years

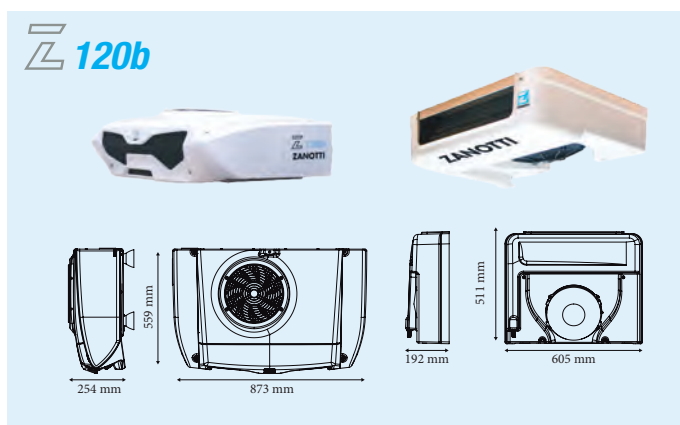

Z120b					
<b>General</b>					
Refrigerant		R452A		R134A	
Refrigerant quantity	kg	1.2		1.05	
<b>System net cooling capacity under ATP conditions (30°C ambient temperature)</b>					
	°C	0°C	-20°C	0°C	-20°C
Battery mode	W	1270	480	810	N/A
Standby mode	W	1035	398	785	N/A
Recommended body volume	m <sup>3</sup>	8	4	6	N/A
<b>Heating capacity</b>					
Battery mode	W	1100		N/A	
<b>Airflow rate</b>					
Airflow rate at 100kPa static pressure	m <sup>3</sup> /h	560		560	
<b>Weight</b>					
Condenser with electric stand-by	kg	47		47	
Evaporator	kg	10,2		10,2	
<b>Dimensions</b>					
Condensing unit	mm	559x873x254		559x873x254	
Evaporator unit	mm	511x655x192		511x655x192	
<b>Max current</b>					
	A	75		55	

This product contains fluorinated greenhouse gases (R452A GWP=2140,5).

Stand-by voltages available: 230/1/50 or 400/3/50

Vehicle voltages available: 12VDC



# Electric Power Supply

Our power supply packages are designed to match our Invisible Electric and Zero Electric ranges, providing a high level of reliability and customization for the specific vehicle and application needs.

The power supply can be configured as one or two DC lithium-ion batteries, each providing 1,25 to 6kW up to 12kW total; and comes with a robust inverter battery charger.

## Key Features:

- Zero emissions
- Zero maintenance
- Automotive-grade design with high reliability
- Long life with 3500 cycles
- Fast charging
- 230VAC power for charging and stand-by operation
- Bluetooth connection with smartphone app
- Compatible with telematics, for remote battery monitoring
- Optional connection to vehicle DC battery for supplementary power supply
- Optional auxiliary input for external power supply



Battery Charger  
Z120b only



Inverter Battery Charger  
SFZ009e / Z200e / Z250e /  
Z350e / Z350e Multi



## Zero Electric

### Z200e | Z250e | Z350e | Z350e Multi

The Zero range meets the needs of the distribution industry by offering the utmost flexibility in the temperature management of refrigerated products. Zero Electric is designed to meet a wide range of applications in light commercial vehicles on electric power, both on road and during stand-by. A highly reliable battery-inverter package supplies the power, making Zero Electric an ideal choice for full-electric, hybrid, or conventional vehicles.

Z200e, Z250e and Z350e offer varying refrigeration capacities and volume ratings tuned for different applications. Z350e Multi features additional evaporators to enable transport of products with different temperature requirements in separate zones.

All Zero models provide easy installation and serviceability. The condensing unit can be installed as top-mount on the roof of the box or nose-mount on the front wall of the box, and the ultra-thin evaporator installed in the cargo compartment maximizes cargo volume. A driver-friendly interface in the cabin allows real-time monitoring and control of unit performance to ensure goods are maintained at precisely the right temperature throughout the trip. Our Zero units are setting new standards with their attractive design.

#### Key Features:

- Zero emissions
- Powered by reliable battery-inverter pack on road, chargeable on electric grid
- Compatible with full-electric, hybrid or conventional vehicles
- Multiple temperature zones in the same vehicle (Multi model only)
- Proven reliability and performance
- Easy to install and service with removable side panels
- Low noise
- Configurable for a wide range of refrigerated applications in light commercial vehicles
- User-friendly cabin driver interface
- Reduced refrigerant charge and maintenance costs
- Telematics-compatible
- 2-year standard warranty



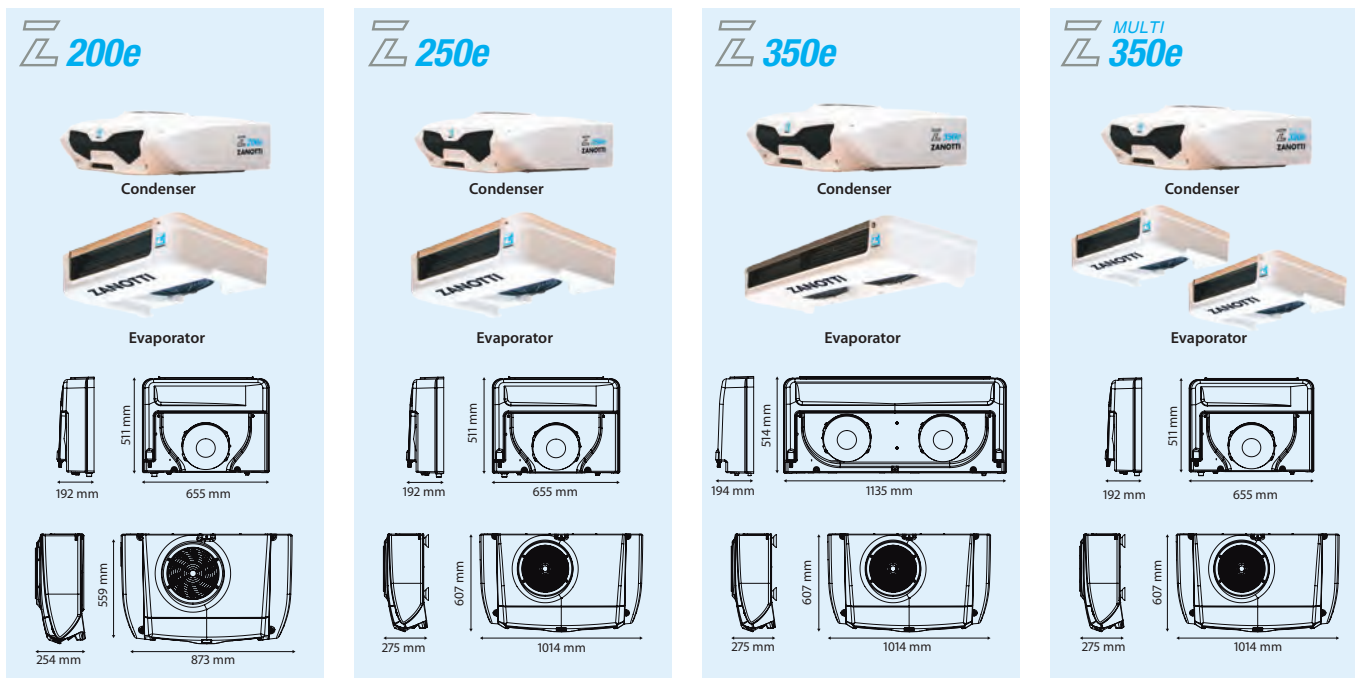

		Z200e	Z250e	Z350e	Z350e Multi				
<b>General</b>									
Refrigerant		R452A							
<b>System net cooling capacity under ATP conditions (30°C ambient temperature)</b>									
	°C	0°C	-20°C	0°C	-20°C	0°C	-20°C	0°C	-20°C
Battery mode	W	1495	695	1735	955	1885	1045	1790	955
Recommended body volume	m <sup>3</sup>	9	6	11	7	12	10	12	9
<b>Heating capacity</b>									
Battery mode	W	1200	1500	1650	1600				
<b>Airflow rate</b>									
Airflow rate at 100kPa static pressure	m <sup>3</sup> /h	620	650	1300	2x 620				
<b>Dimensions (LxWxH)</b>									
Condensing unit	mm	559x873x254	607x1014x275	607x1014x275	607x1014x275				
Evaporator unit	mm	511x655x192	511x655x192	514x1135x194	(2x) 511x655x192				
<b>Weight</b>									
Condenser with electric stand-by	kg	54	70	70	70				
Evaporator	kg	10,2	10,5	19,6	2X 10,2				
<b>Max current</b>									
	A	100	159	166	171				

These products contain fluorinated greenhouse gases (R452A GWP=2140,5).

Stand-by voltages available: 230/1/50 or 400/3/50

Vehicle voltages available: 12VDC or 24VDC



# Light Truck





## SFZ

### SFZ238 | SFZ248 | SFZ268

SFZ is a robust direct-drive solution for refrigerated transport on light to medium trucks. It is a proven design optimized for energy-efficiency, low noise, and easy-to-service transport of temperature-controlled goods in medium sized boxes.

SFZ238, SFZ248 and SFZ268 are designed as nose-mount, installed on the front wall of the box, with multiple configurations of evaporators and fans to meet the requirements of a wide range of vehicle types and applications. A driver-friendly interface in the cabin allows real-time monitoring and control of unit performance to ensure goods are maintained at precisely the right temperature throughout the trip.

#### Key Features:

- Proven reliability and performance
- Powered by direct-drive on engine, electric stand-by
- Easy to install and service, light weight
- Low noise
- Configurable for a wide range of refrigerated applications in light to medium trucks
- User-friendly cabin driver interface
- Telematics-compatible
- 2-year standard warranty



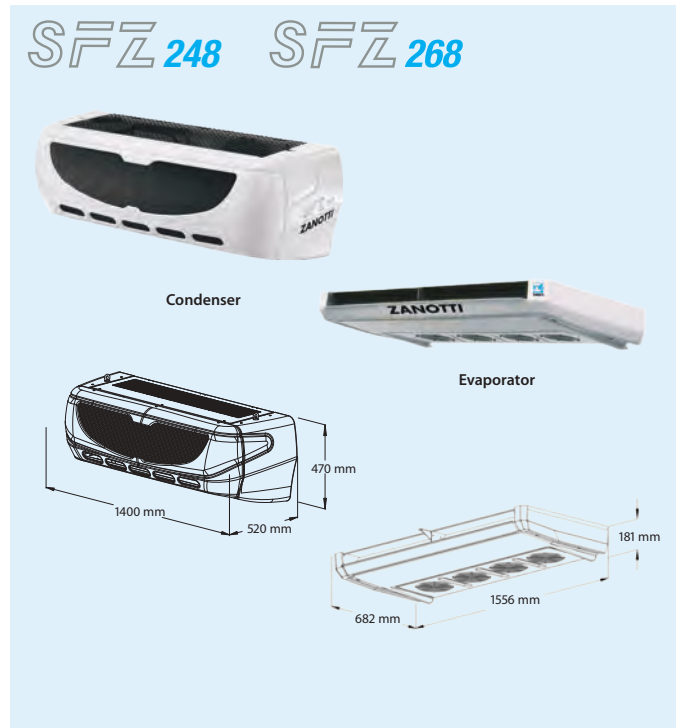
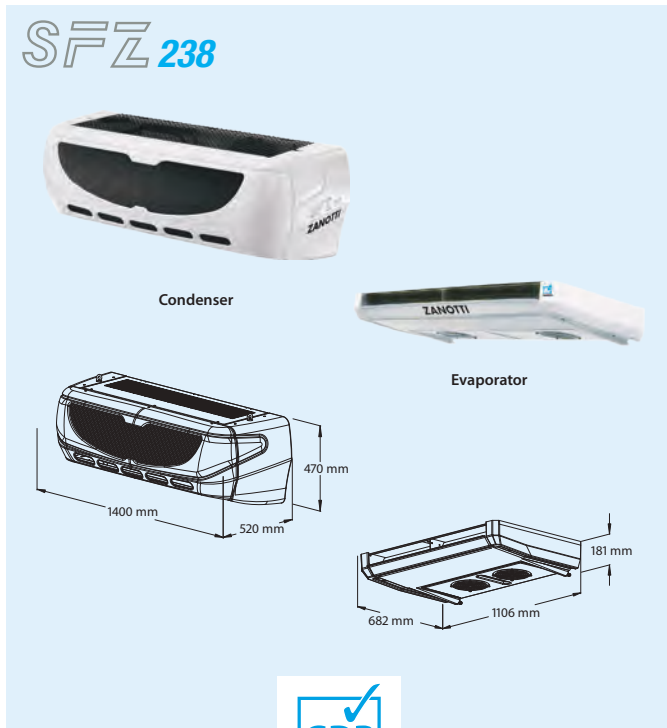

		SFZ238	SFZ248	SFZ268			
<b>General</b>							
Refrigerant		R452A					
Refrigerant quantity	kg	3.5	4	4.0			
Road Compressor		QP16/UPF170	QP16/UPF170	QP21			
<b>System net cooling capacity under ATP conditions (30°C ambient temperature)</b>							
	°C	0°C	-20°C	0°C	-20°C	0°C	-20°C
Road mode	W	4515	2500	5100	2570	6035	3225
Stand-by mode	W	3715	1900	4405	2005	4640	1740
Recommended body volume	m <sup>3</sup>	36	28	42	31	57	42
<b>Heating capacity</b>							
Road mode	W	3990	4540	4000			
Stand-by mode	W	3310	2800	3350			
<b>Airflow rate</b>							
Airflow rate at 100kPa static pressure	m <sup>3</sup> /h	1670	3340	1822			
<b>Dimensions (LxWxH)</b>							
Condensing unit	mm	520x1400x470	520x1400x470	1400x520x470			
Evaporator unit	mm	682x856x181	682x1556x181	1556x682x181			
<b>Weight</b>							
Condenser without electric stand-by	kg	70	77	85			
Condenser with electric stand-by	kg	128	143	145			
Evaporator	kg	26,5	42,5	40			

These products contain fluorinated greenhouse gases (R452A GWP=2140,5).

Stand-by voltages available: 230/1/50 or 400/3/50

Vehicle voltages available: 12VDC or 24VDC

# SFZ Multi-Temp

## SFZ238 Multi | SFZ248 Multi | SFZ268 Multi

Our SFZ Multi-Temp range is designed to meet the modern needs of refrigeration for light to medium trucks. These units feature additional evaporators to enable transport of products with different temperature requirements in separate zones, available in multiple configurations to adapt to a wide range of applications. It is a proven design optimized for energy-efficiency, low noise, and easy-to-service transport of temperature-controlled goods in medium-sized boxes.

SFZ238 Multi, SFZ248 Multi, SFZ268 Multi are designed as nose-mount, installed on the front wall of the box. A driver-friendly interface in the cabin allows real-time monitoring and control of unit performance to ensure goods are maintained at precisely the right temperature throughout the trip.

### Key Features:

- Multiple temperature zones in the same vehicle
- Proven reliability and performance
- Powered by direct-drive on engine, electric stand-by
- Easy to install and service, lightweight
- Low noise
- Configurable for a wide range of refrigerated applications in light to medium trucks
- User-friendly cabin driver interface
- Telematics-compatible
- 2-year standard warranty

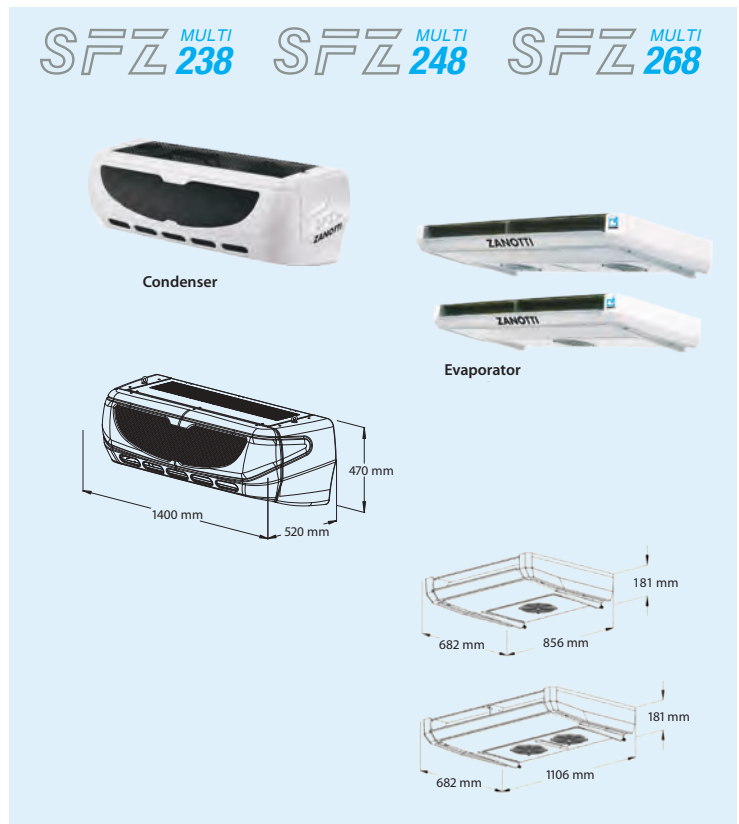

		SFZ238 Multi	SFZ248 Multi	SFZ268 Multi			
<b>General</b>							
Refrigerant		R452A					
Refrigerant quantity	kg	4.6	4.6	4.6			
Road compressor		QP16/UPF170	QP16/UPF170	QP21			
<b>System net cooling capacity under ATP conditions (30°C ambient temperature)</b>							
	°C	0°C	-20°C	0°C	-20°C	0°C	-20°C
Road mode	W	4240	2135	5085	2255	6035	3150
Stand-by mode	W	3404	1250	3553	1320	4430	2015
Recommended body volume	m <sup>3</sup>	N/A	21	N/A	27	N/A	38
<b>Heating capacity</b>							
Road mode	W	3850		4430		4450	
Stand-by mode	W	3230		3610		3650	
<b>Airflow rate</b>							
Airflow rate at 100kPa static pressure	m <sup>3</sup> /h	2x 835		2x 1670		2x1289	
<b>Dimension (LxWxH)</b>							
Condensing unit	mm	520x1400x470		520x1400x470		1400x520x181	
Condenser with electric stand-by	kg	(2x) 682x856x181		(2x) 682x1106x181		(2x) 1106x6082x181	
<b>Weight</b>							
Condenser without electric stand-by	kg	70		77		95	
Condenser with electric stand-by	kg	128		143		153	
Evaporator	kg	2x20		2x42,5		2x27	

These products contain fluorinated greenhouse gases (R452A GWP=2140,5).

Stand-by voltages available: 230/1/50 or 400/3/50

Vehicle voltages available: 12VDC or 24VDC

# Truck





## Uno

### U600 | U800 | U1000

The redesigned Uno range of units are independently powered with a diesel engine, and available in various capacities to efficiently transport temperature-controlled products in medium to heavy trucks. The Uno features Zanotti's innovative direct coupling design between the engine and the compressor, and utilize Daikin's expertise in design for reliability and performance. Their high cooling performance, energy efficiency and extended maintenance intervals minimise the total cost of ownership, while meeting the most stringent emission, material waste, and noise pollution regulations.

U600, U800, and U1000 are designed as nose-mount, installed on the front wall of the box. The electronics enabled advanced diagnostics. A robust interface in the cabin can be installed in the vehicle DIN slot or mounted on the dash, allowing real-time monitoring and control of unit performance to ensure goods are maintained at precisely the right temperature throughout the trip.

#### Key Features:

- Designed for high reliability with a custom Yanmar engine
- Innovative powertrain design enabling high performance and energy efficiency
- Reduced fuel consumption and noise
- Extended maintenance intervals
- 2-year standard warranty



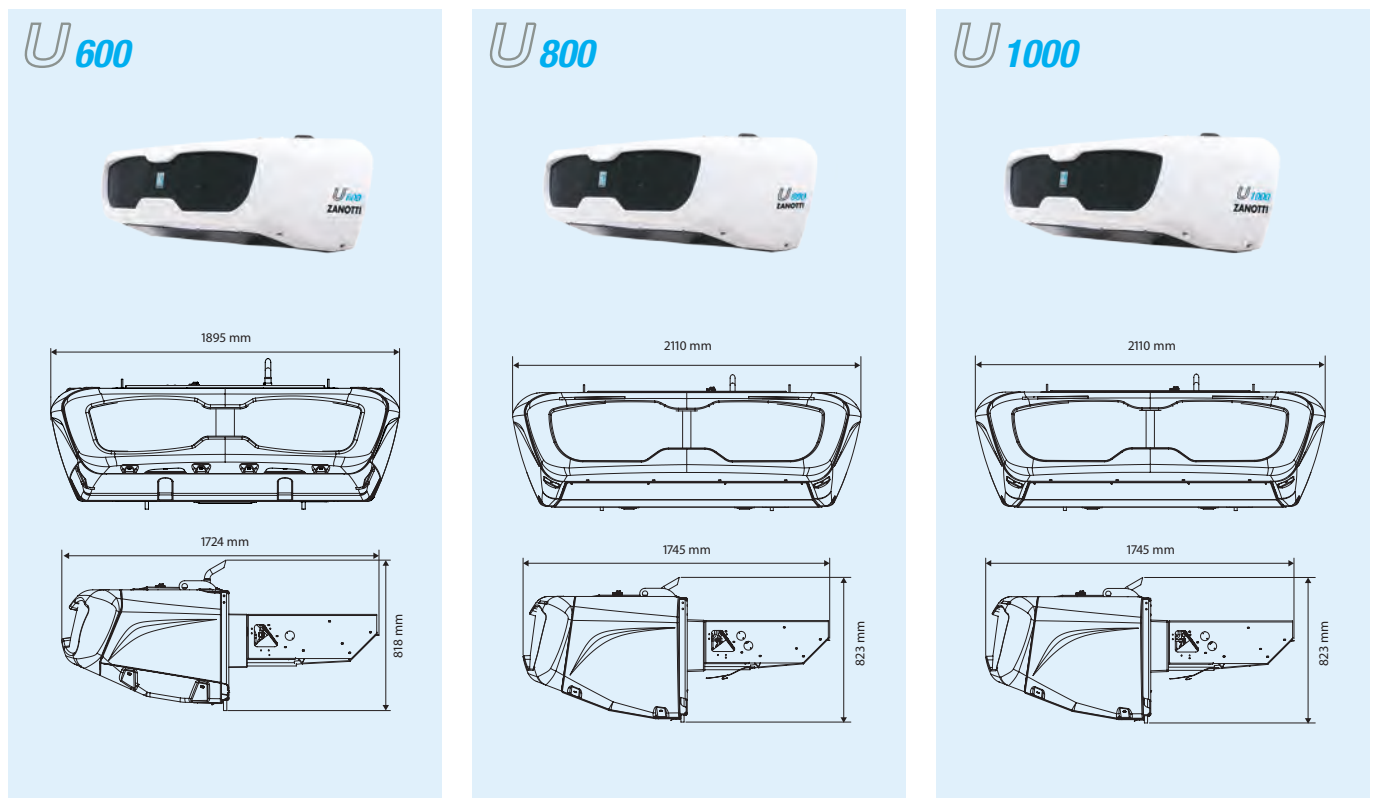

		U600	U800	U1000			
<b>General</b>							
Refrigerant		R452A					
Defrost		Hot gas defrost					
Refrigerant quantity	kg	3.6	4.8	4.8			
<b>System net cooling capacity under ATP conditions (30°C ambient temperature)</b>							
	°C	0°C	-20°C	0°C	-20°C	0°C	-20°C
Road mode	W	5880	3160	9030	4700	10025	5655
Stand-by mode	W	3315	1615	6455	3475	8340	4500
Recommended body volume	m <sup>3</sup>	57	42	66	55	80	70
<b>Heating capacity</b>							
Road mode	W	5400		7500		8700	
Stand-by mode	W	3200		5700		7200	
<b>Airflow rate</b>							
Airflow rate at 100kPa static pressure	m <sup>3</sup> /h	1500		2200		2500	
Air Throw	m	6,5		7,5		8,5	
<b>Weight</b>							
Monoblock road and stand-by	kg	485		500		549	
Monoblock road-only	kg	435		455		504	
<b>Diesel engine</b>							
Displacement	cc	854		1116		1116	
Rated power output	kW	11,5		15,1		15,1	
Maintenance interval	hrs	2000		2000		2000	
<b>Road compressor</b>							
Displacement	cc	235		325		390	
<b>Stand-by compressor</b>							
Displacement	m <sup>3</sup> /h	11,3		14,4		21,4	

These products contain fluorinated greenhouse gases (R452A GWP=2140,5).

Stand-by voltages available: 400/3/50



## Uno

### U800 Multi | U1000 Multi

The redesigned Uno range of units are independently powered with a diesel engine, and available in various capacities to efficiently transport temperature-controlled products in medium to heavy trucks. The Uno features Zanotti's innovative direct coupling design between the engine and the compressor, and utilise Daikin's expertise in design for reliability and performance. Their high cooling performance, energy efficiency and extended maintenance intervals minimise the total cost of ownership, while meeting the most stringent emission, material waste, and noise pollution regulations.

U800 Multi and U1000 Multi are designed as nose-mount, installed on the front wall of the box, with multiple configurations of evaporators and fans to meet the requirements of a wide range of vehicle types and applications. The electronics enabled advanced diagnostics. A robust interface in the cabin can be installed in the vehicle DIN slot or mounted on the dash, allowing real-time monitoring and control of unit performance to ensure goods are maintained at precisely the right temperature throughout the trip.

#### Key Features:

- Multiple temperature zones in the same vehicle
- Designed for high reliability with a custom Yanmar engine
- Innovative powertrain design enabling high performance and energy efficiency
- Reduced fuel consumption and noise
- Extended maintenance intervals
- 2-year standard warranty, extendable up to 5 years

The all-new Uno cabin controller is modern technology in a robust build.



## U800 Multi | U1000 Multi

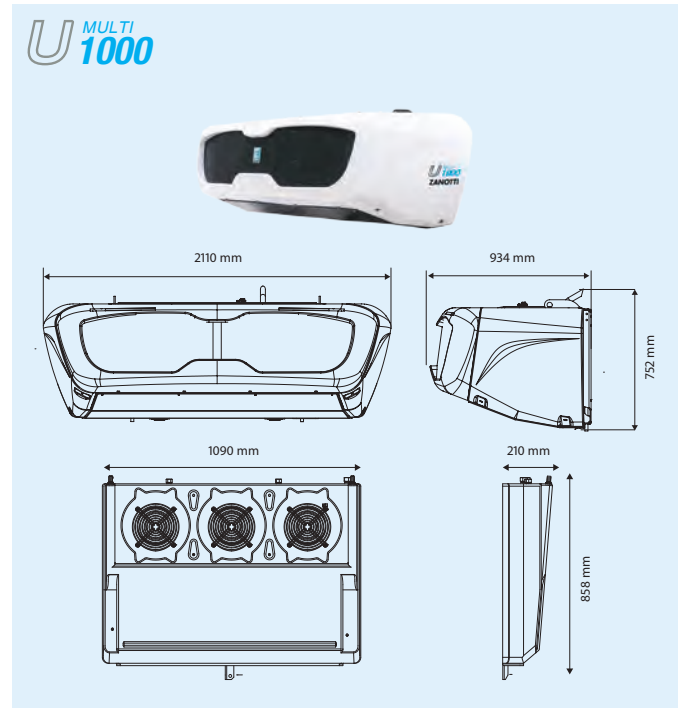
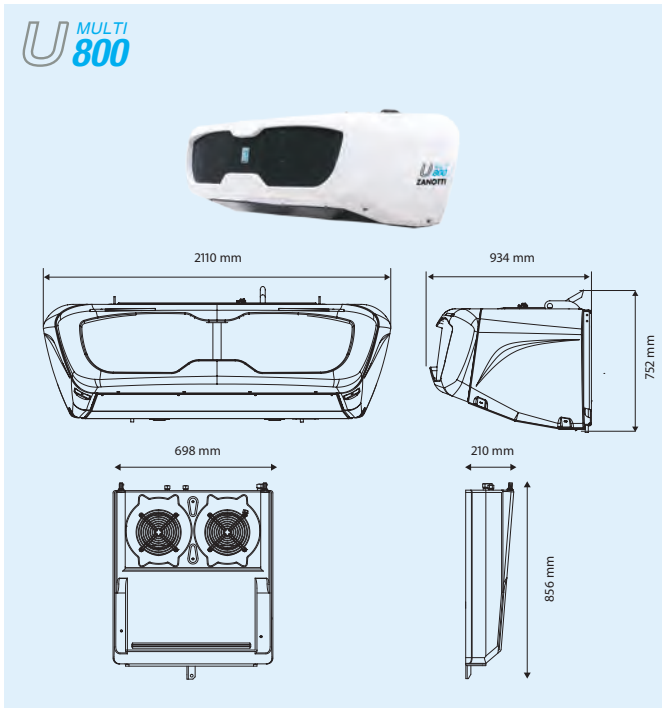

	U800 Multi		U1000 Multi		
<b>General</b>					
Refrigerant		R452A			
Defrost		Hot gas defrost			
Refrigerant quantity	kg	5		5.6	
<b>System net cooling capacity under ATP conditions (30°C ambient temperature)</b>					
	°C	0°C	-20°C	0°C	-20°C
Road mode	W	7970	4140	9830	5410
Stand-by mode	W	6050	3075	8650	4450
Recommended body volume	m <sup>3</sup>	N/A	45	N/A	62
<b>Heating capacity</b>					
Road mode	W	7300		8500	
Stand-by mode	W	4900		7600	
<b>Airflow rate</b>					
Airflow rate at 100kPa static pressure	m <sup>3</sup> /h	2x 1680		2x 2520	
Air Throw	m	7,5		8,5	
<b>Weight</b>					
Split road and stand-by	kg	500		505	
Monoblock road-only	kg	460		465	
Evaporator	kg	35 x 2		40 x 2	
<b>Diesel engine</b>					
Displacement	cc	1116		1116	
Rated power output	kW	13,2		13,2	
Maintenance interval	hrs	2000		2000	
<b>Road compressor</b>					
Displacement	cc	325		390	

These products contain fluorinated greenhouse gases (R452A GWP=2140,5).

Stand-by voltages available: 400/3/50

# Trailer





# Exigo

## E1500

**Daikin Exigo is the new benchmark in trailer refrigeration – built for the needs of today, and the challenges of tomorrow.**

Every aspect of Exigo has been designed to provide high performance, energy-efficient and reliable transport of refrigerated cargo. It is the next generation in trailer refrigeration, being engine-powered, and compatible with battery technologies.

### Key Features:

- Unique electric architecture with Daikin inverter technology providing 15kW true capacity both on engine and electric power
- Variable-speed compressor and fans for maximum pull-down performance and energy efficiency
- Reduced maintenance downtime with industry leading service intervals (3000 hours as standard)
- Low noise as standard
- Ease of unit operation with high resolution graphical user interface
- Daikin components with proven reliability and a lightweight design
- GDP-compliant, supporting cold chain integrity of pharmaceuticals and medicinal products
- Telematics with 2-year subscription included as standard
- EMEA sales and service network backed by Daikin



High resolution graphical user interface



Advanced telematics included as standard



**INVERTER**



**Non-Inverter**

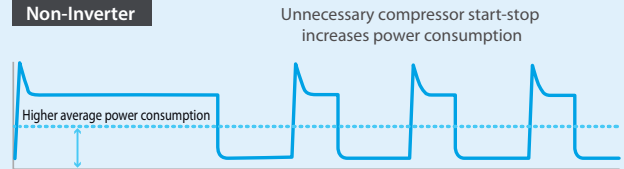

Inverter reduces power and fuel consumption by eliminating unnecessary compressor start-stop

Specifications		E1500
Cooling capacity 30/0°C - Engine & Electric	W	15630
Cooling capacity 30/-20°C - Engine & Electric	W	9660
Heating capacity -20/+2°C - Engine & Electric	W	10500
Air Flow rate evaporator at max pulldown	m <sup>3</sup> /h	5500
Air throw	m	15
Engine		Kubota Custom Diesel Engine 1500 cc / 4 Cylinders NRMM Stage V Compliant
Generator		15kW / 400V 3P 50Hz / Direct Drive
Compressor		Custom scroll compressor   economizer   inverter Variable speed
Variable speed components		Compressor   Evaporator fans   Condenser Fans
Controller		Daikin PCB
User interface		7" High Resolution LCD
Temperature zones		Single
Refrigerant		R-452A
Total net weight	kg	730
Unit Dimensions W x H x D	mm	2072 x 2227 x 440
Refrigerant quantity	kg	5.1
Connectivity		Telematics as Standard with 2-Year Subscription Included
Pharma		Certicold GDP certification
Power supply		
Voltage	V	400
Phase		3P+N
Frequency	Hz	50

# Exigo Accessories

## Solar Panel

### Key Features:

- Extends Exigo 12V battery life and efficiency
- Improves fuel efficiency by charging the 12V battery
- Keeps telematics active during long standby

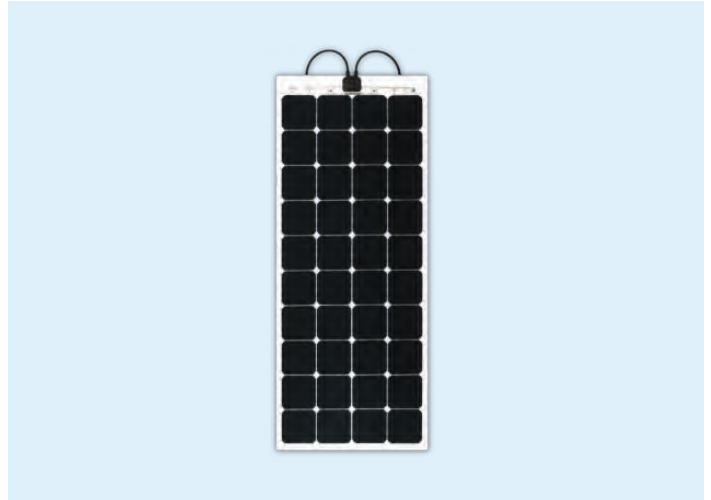

Specifications		Solar Panel
Power	W	138
Weight	Kg	1.8
Length	mm	1363
Width	mm	546
Thickness	mm	2

## Datalogger

### Key Features:

- Enables independent cold chain monitoring
- Includes 2 temperature sensors extendable to 6
- Includes integrated printer



# Service Network



Our continuously growing European service network, extending to over 300 authorized service partners, enabled by Daikin to provide repair and maintenance services for our van, truck, and trailer units. Our service partners always apply our genuine spare parts, engineered to ensure maximum performance and reliability. Utilising the authorized service partners and genuine parts is the only way to protect your investment under Daikin warranty and minimise total cost of ownership.









Discover our portfolio,  
partner locator and more



linkedin.com/company/  
daikin-transport-refrigeration

**Daikin Europe N.V.** Naamloze Vennootschap Zandvoordestraat 300 · 8400 Oostende · Belgium · www.daikin.eu · BE 0412 120 336 · RPR Oostende (Responsible Editor)

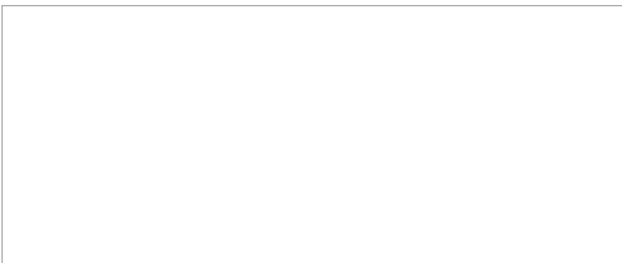

05/2026



The present publication is drawn up by way of information only and does not constitute an offer binding upon Daikin Europe N.V. Daikin Europe N.V. has compiled the content of this publication to the best of its knowledge. No express or implied warranty is given for the completeness, accuracy, reliability or fitness for particular purpose of its content and the products and services presented therein. Specifications are subject to change without prior notice. Daikin Europe N.V. explicitly rejects any liability for any direct or indirect damage, in the broadest sense, arising from or related to the use and/or interpretation of this publication. All content is copyrighted by Daikin Europe N.V.