

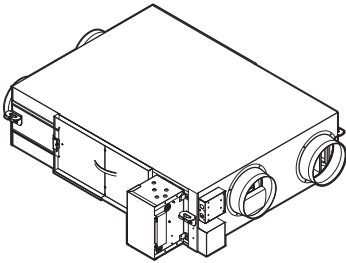

Installation and operation manual



Heat reclaim ventilation unit



VAM350J ▲ VEB ▼
VAM500J ▲ VEB ▼
VAM650J ▲ VEB ▼
VAM800J ▲ VEB ▼
VAM1000J ▲ VEB ▼
VAM1500J ▲ VEB ▼
VAM2000J ▲ VEB ▼

▲ = 1, 2, 3, ..., 9, A, B, C, ..., Z
▼ = , , 1, 2, 3, ..., 9

Installation and operation manual
Heat reclaim ventilation unit

English

Table of contents

1	About the documentation	2
1.1	About this document.....	2
2	Specific installer safety instructions	2
For the user 4		
3	User safety instructions	4
3.1	General.....	4
3.2	Instructions for safe operation.....	5
4	User interface	5
5	Maintenance and service	5
5.1	Maintenance of the air filter.....	5
5.2	Maintenance of the heat exchange element.....	6
6	Troubleshooting	6
7	Relocation	7
8	Disposal	7
For the installer 7		
9	About the box	7
9.1	Heat reclaim ventilation unit.....	7
9.1.1	To remove the accessories.....	7
10	About the heat reclaim ventilation unit	7
10.1	About the EKVDX option.....	8
11	Unit installation	8
11.1	Preparing the installation site.....	8
11.1.1	Installation site requirements for the heat reclaim ventilation unit.....	8
11.2	Preparing the unit.....	8
11.2.1	To install the optional adapter PCB.....	8
11.2.2	To install the duct flanges.....	9
11.2.3	To install the EKVDX option.....	9
11.3	Unit orientation.....	9
11.4	To install the anchor bolts.....	10
11.5	Duct connections.....	11
12	Electrical installation	11
12.1	Component electrical specifications.....	11
12.2	Specifications for field supplied fuses and wires.....	12
12.3	Opening the switch box.....	12
12.4	Electrical connections for additional field supplied damper.....	15
12.5	To connect the electrical wiring.....	15
13	Configuration	16
13.1	To change settings.....	16
	Case 1: Change settings with BRC1E53.....	16
	Case 2: Change settings with BRC301B61.....	17
	Case 3: Change settings with BRC1H.....	17
	Case 4: Change settings with BRC1K.....	17
13.2	Field settings.....	18
13.3	Settings for all configurations.....	20
13.3.1	About settings 19(29)-0-04 and 19(29)-0-05.....	21
13.4	About the controller.....	21
13.4.1	BRC1E53 controller.....	21
13.4.2	BRC301B61 controller.....	22
13.4.3	BRC1H controller.....	23
13.4.4	BRC1K controller.....	23
14	Commissioning	23

14.1	Checklist before commissioning.....	23
14.2	Checklist during commissioning.....	24
14.2.1	About the system test run.....	24
15	Troubleshooting	24
15.1	Solving problems based on error codes.....	24
15.1.1	Error codes: Overview.....	24
16	Disposal	25
17	Technical data	25
17.1	Wiring diagram.....	25
17.2	Service space.....	26

1 About the documentation

1.1 About this document



INFORMATION

Make sure that the user has the printed documentation and ask him/her to keep it for future reference.

Target audience

Authorised installers + end users



INFORMATION

This appliance is intended to be used by expert or trained users in shops, in light industry and on farms, or for commercial use by lay persons.

Documentation set

This document is part of a documentation set. The complete set consists of:

- **General safety precautions:**
 - Safety instructions that you **MUST** read before installing
 - Format: Paper (in the accessory bag of the heat reclaim ventilation unit)
- **Heat reclaim ventilation unit installation and operation manual:**
 - Installation and operation instructions
 - Format: Paper (in the accessory bag of the heat reclaim ventilation unit)
- **Installer and user reference guide:**
 - Preparation of the installation, good practices, reference data,...
 - Detailed step-by-step instructions and background information for basic and advanced usage
 - Format: Digital files on <https://www.daikin.eu>. Use the search function to find your model.

The latest revision of the supplied documentation is published on the regional Daikin website and is available via your dealer.

The original instructions are written in English. All other languages are translations of the original instructions.

Technical engineering data

- A **subset** of the latest technical data is available on the regional Daikin website (publicly accessible).
- The **full set** of the latest technical data is available on the Daikin Business Portal (authentication required).

2 Specific installer safety instructions

Always observe the following safety instructions and regulations.

2 Specific installer safety instructions

Unit installation (see "11 Unit installation" ▶ 8)



WARNING

Fixing method of the heat reclaim ventilation unit **MUST** be in accordance with the instructions from this manual. See "11.4 To install the anchor bolts" ▶ 10].



WARNING

The appliance shall be stored in a room without continuously operating ignition sources (example: open flames, an operating gas appliance or an operating electric heater).



CAUTION

Appliance is **NOT** accessible to the general public. Install it in a secured area, protected from easy access.

This unit is suitable for installation in a commercial and light industrial environment.



WARNING

When connected to an EKVDX, the height of the air extraction opening from the room **MUST** be equal or below the refrigerant release point.



CAUTION

- The appliance is designed to be a built-in appliance. It may **NOT** be accessible to the general public. Adequate measures have to be taken to prevent access by other than qualified persons.
- Check if the installation location can support the unit's weight. Poor installation is hazardous. It can also cause vibrations or unusual operating noise.
- Provide sufficient service space and inspection holes. Inspection holes are needed for the air filters, the heat exchange elements and the fans.
- Do **NOT** install the unit so that it is in contact with a ceiling or wall, this may cause vibration.



CAUTION

- A minimum length of 1.5 m is required for the outdoor air, exhaust air and return air ducting. If the ducting is shorter, or if no ducting is installed, then you **MUST** install grilles in the duct openings or the openings of the unit.
- Make sure no wind can blow in the ducting.



WARNING

When combined with an EKVDX unit, do **NOT** install operating ignition sources (example: open flames, an operating gas appliance or an operating electric heater) in the duct work.

Electrical installation (see "12 Electrical installation" ▶ 11)



WARNING

Electrical wiring **MUST** be in accordance with the instructions from this manual. See "12 Electrical installation" ▶ 11].



WARNING

- All wiring **MUST** be performed by an authorised electrician and **MUST** comply with the national wiring regulation.
- Make electrical connections to the fixed wiring.
- All components procured on-site and all electrical construction **MUST** comply with the applicable legislation.



WARNING

- After finishing the electrical work, confirm that each electrical component and terminal inside the switch box is connected securely.
- Make sure all covers are closed before starting up the unit.



WARNING

If **NOT** factory installed, a main switch or other means for disconnection, having a contact separation in all poles providing full disconnection under overvoltage category III condition, **MUST** be installed in the fixed wiring.



WARNING

- **ONLY** use copper wires.
- Make sure the field wiring complies with the applicable legislation.
- All field wiring **MUST** be performed in accordance with the wiring diagram supplied with the product.
- **NEVER** squeeze bundled cables and make sure they do **NOT** come into contact with the piping and sharp edges. Make sure no external pressure is applied to the terminal connections.
- Make sure to install earth wiring. Do **NOT** earth the unit to a utility pipe, surge absorber, or telephone earth. Incomplete earthing may cause electrical shock.
- Make sure to install the required fuses or circuit breakers.
- Make sure to install an earth leakage protector. Failure to do so may cause electrical shock or fire.



CAUTION

Before opening the cover, be sure to turn off the power switches of the main units and other devices connected to the main units.

- Remove the screws that secure the cover and open the switch box.
- Secure the power supply cable and the control wire with a tie wrap, as shown in the figures.



WARNING

If a gap is present at the cable entry, wrap the cable (or cables) with the sealing material from the accessory bag.

This will prevent small objects (such as children's fingers, ... etc.) as well as fluid droplets from entering the unit.

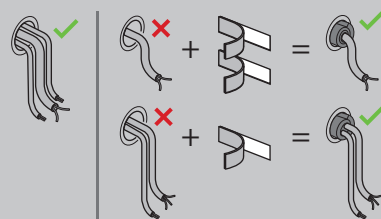

WARNING

Prevent hazards due to inadvertent resetting of the thermal cut-out: power to this appliance **MUST NOT** be supplied through an external switching device, such as a timer, or connected to a circuit that is regularly turned **ON** and **OFF** by the utility.

3 User safety instructions

WARNING

- When carrying out an inspection on the switch box of the unit, ALWAYS make sure that the unit is disconnected from the mains. Turn off the respective circuit breaker.
- When a safety device was activated, stop the unit and find out why the safety device was activated before resetting it. NEVER shunt safety devices or change their values to a value other than the factory default setting. If you are unable to find the cause of the problem, call your dealer.

WARNING

- If the power supply has a missing or wrong N-phase, equipment might break down.
- Establish proper earthing. Do NOT earth the unit to a utility pipe, surge absorber, or telephone earth. Incomplete earthing may cause electrical shocks.
- Install the required fuses or circuit breakers.
- Secure the electrical wiring with cable ties so that the cables do NOT come in contact with sharp edges or piping, particularly on the high-pressure side.
- Do NOT install a phase advancing capacitor, because this unit is equipped with an inverter. A phase advancing capacitor will reduce performance and may cause accidents.

WARNING

- Do NOT extend the power supply or the interconnection cable by using wire connectors, wire connection clamps, taped wires, extension cords. These can cause overheating, electric shock or fire.

WARNING

- ALWAYS use multicore cable for power supply cables.

WARNING

- Use an all-pole disconnection type breaker with at least 3 mm between the contact point gaps that provides full disconnection under overvoltage category III.

CAUTION

- In case of combination with an EKVDX option using R32 refrigerant, do NOT turn off the circuit breaker, unless you smell something burning, or during a short repair period, inspection, or cleaning of the unit. Otherwise, R32 refrigerant leakage CANNOT be detected.

WARNING

- If the supply cord is damaged, it MUST be replaced by the manufacturer, its service agent or similarly qualified persons in order to avoid a hazard.

Commissioning (see "[14 Commissioning](#)" ▶ 23)]

WARNING

- Commissioning MUST be in accordance with the instructions from this manual. See "[14 Commissioning](#)" ▶ 23].

For the user

3 User safety instructions

Always observe the following safety instructions and regulations.

3.1 General

WARNING

- If you are NOT sure how to operate the unit, contact your installer.

WARNING

This appliance can be used by children aged from 8 years and above and persons with reduced physical, sensory or mental capabilities or lack of experience and knowledge if they have been given supervision or instruction concerning use of the appliance in a safe way and understand the hazards involved.

Children SHALL NOT play with the appliance.

Cleaning and user maintenance SHALL NOT be made by children without supervision.

WARNING

To prevent electrical shocks or fire:

- Do NOT rinse the unit.
- Do NOT operate the unit with wet hands.
- Do NOT place any objects containing water on the unit.

CAUTION

- Do NOT place any objects or equipment on top of the unit.
- Do NOT sit, climb or stand on the unit.

- Units are marked with the following symbol:



This means that electrical and electronic products may NOT be mixed with unsorted household waste. Do NOT try to dismantle the system yourself: dismantling the system, treatment of the refrigerant, of oil and of other parts MUST be done by an authorised installer and MUST comply with applicable legislation.

Units MUST be treated at a specialised treatment facility for reuse, recycling and recovery. By ensuring this product is disposed of correctly, you will help to prevent potential negative consequences for the environment and human health. For more information, contact your installer or local authority.

- Batteries are marked with the following symbol:



This means that the batteries may NOT be mixed with unsorted household waste. If a chemical symbol is printed beneath the symbol, this chemical symbol means that the battery contains a heavy metal above a certain concentration.

Possible chemical symbols are: Pb: lead (>0.004%).

Waste batteries MUST be treated at a specialised treatment facility for reuse. By ensuring waste batteries are disposed of correctly, you will help to prevent potential negative consequences for the environment and human health.

3.2 Instructions for safe operation



CAUTION

During operation, NEVER check or clean the unit. It may cause electrical shock. Do NOT touch the rotating parts, it will cause injury.



CAUTION

This unit is equipped with electrically powered safety measures that are required when connected to an EKVDX. In order to be effective, the installed unit MUST be electrically powered at all times, except for short service periods.



CAUTION

Before accessing, make sure to turn OFF the operation switch and disconnect the power.



WARNING

Stop operation and shut OFF the power if anything unusual occurs (burning smells etc.).

Leaving the unit running under such circumstances may cause breakage, electrical shock or fire. Contact your dealer.

4 User interface

This operation manual offers a non-exhaustive overview of the main functions of the system.

Detailed information on required actions to achieve certain functions can be found in the dedicated installation and operation manual of the indoor unit.

Refer to the operation manual of the installed controller.

5 Maintenance and service



CAUTION

See "3 User safety instructions" [▶ 4] to acknowledge all related safety instructions.



NOTICE

Maintenance MUST be done by an authorised installer or service agent.

We recommend performing maintenance at least once a year. However, applicable legislation might require shorter maintenance intervals.



NOTICE

We recommend to clean at least once every 2 years (for general office use). If necessary, shorter maintenance intervals might be required.

5.1 Maintenance of the air filter



NOTICE

- Do NOT wash the air filter in hot water.
- Do NOT dry the air filter over a fire.
- Do NOT subject the air filter to direct sunlight.
- Do NOT use organic solvents, such as gasoline or thinner, on the air filter.
- Make sure to install the air filter after servicing (missing air filter causes clogged heat exchange element). Replacement air filters are available.

To clean the air filters

- Go into the ceiling through the inspection hole, loosen the screw of the hinge mechanism (on the left side) to open the service cover. Take the service cover off by rotating it around the vertical axis of the hanging metal.

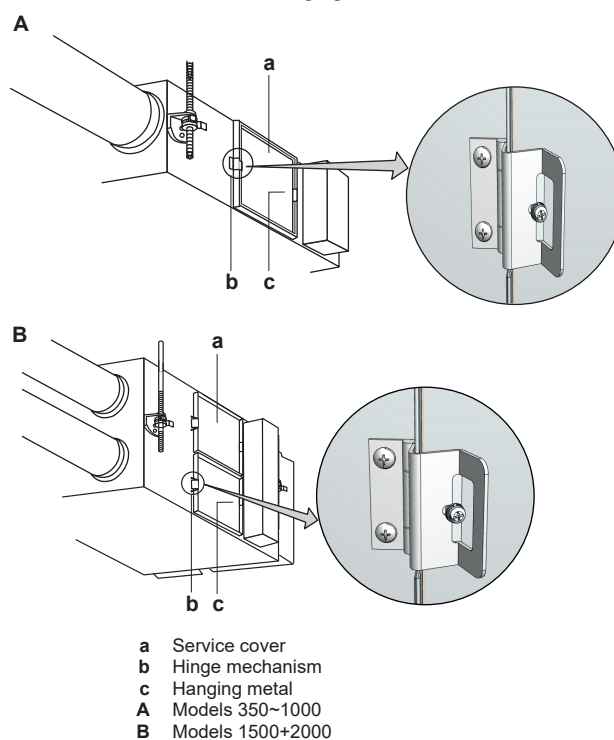

- Take out the air filters from the unit body.

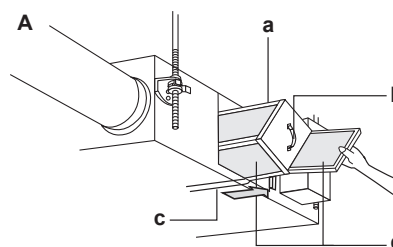

6 Troubleshooting

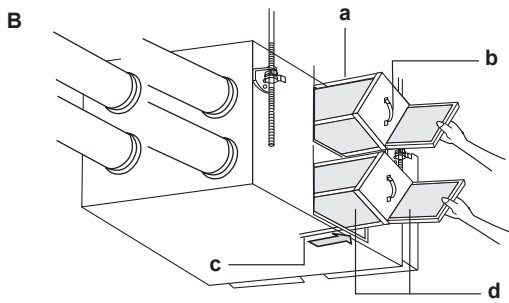

- a Heat exchange element
- b Handle
- c Rail
- d Air filter
- A Models 350~1000
- B Models 1500+2000

- 3 To clean the air filter, lightly pat it with your hand or remove dust with a vacuum cleaner. If excessively dirty, wash it in water.

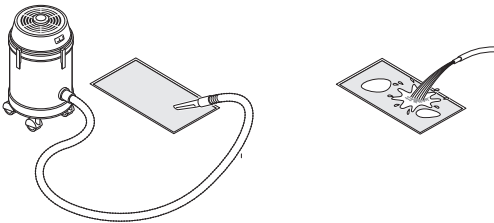

- 4 If the air filter is washed, remove water completely and allow to dry for 20 to 30 minutes in the shade.
- 5 When dried completely, install the air filter back in place after the installation of the heat exchange element. Make sure the air filter is orientated correctly, as shown in the figure.

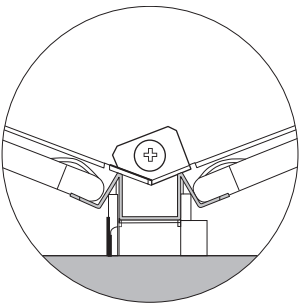

- 6 Install the service cover securely in place.

5.2 Maintenance of the heat exchange element



NOTICE

- NEVER wash the heat exchange element with water.
- NEVER touch the heat exchange element paper because it can be damaged if it is forced.
- Do NOT crush the heat exchange element.

To clean the heat exchange element

- 1 Take out the heat exchange elements. Refer to "5.1 Maintenance of the air filter" [▶ 5].
- 2 Equip a vacuum cleaner with a brush on the end of the suction nozzle.
- 3 Use the vacuum cleaner and lightly apply the brush to the surface of the heat exchange element to remove dust.

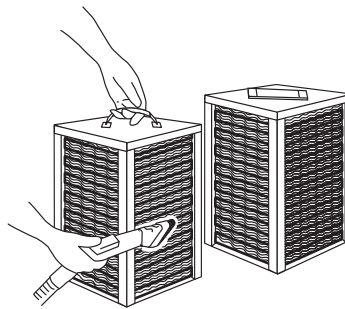

- 4 Place the heat exchange element on the rail and insert it in the unit.
- 5 Install the air filters in the unit.
- 6 Install the service cover.

6 Troubleshooting

If one of the following malfunctions occurs, take the measures shown below and contact your dealer.

The system MUST be repaired by a qualified service person.

Malfunction	Measure
If a safety device such as a fuse, a breaker or an earth leakage breaker frequently actuates or the ON/OFF switch does NOT properly work.	Turn OFF the main power switch.
If water leaks from the unit.	Stop the operation.
The operation switch does NOT work well.	Turn OFF the power supply.
If the controller display indicates the unit number, the operation lamp flashes and the malfunction code appears.	Notify your installer and report the malfunction code.

If the system does NOT operate properly except for the above mentioned cases and none of the above mentioned malfunctions is evident, investigate the system in accordance with the following procedures.

Malfunction	Measure
The system does NOT operate at all.	<ul style="list-style-type: none"> • Check if there is no power failure. Wait until power is restored and restart operation. • Check if no fuse has blown or breaker is activated. Change the fuse or reset the breaker if necessary. • Check if the indication of the operation control method on the controller is shown. This is normal. Operate the unit using the air conditioner remote control or the central controller. Refer to "13 Configuration" [▶ 16]. • Check if the indication of operation standby is displayed on the controller, indicating that the unit is precooling/preheating. The unit is at stop and will start operation after the precooling/preheating operation is completed. Refer to "13 Configuration" [▶ 16].
The amount of discharged air is small and the discharging sound is high.	<ul style="list-style-type: none"> • Check if the air filter and heat exchange element are NOT clogged. Refer to "5 Maintenance and service" [▶ 5].
The amount of discharged air is large and the discharging sound is high.	<ul style="list-style-type: none"> • Check if the air filter and heat exchange element are installed. Refer to "5 Maintenance and service" [▶ 5].

i INFORMATION

The unit may not operate as requested due to a filter contamination check.

In case a malfunction code appears on the indoor unit controller display, contact your installer and inform the malfunction code, the unit type, and serial number (you can find this information on the nameplate of the unit).

For your reference, a list with malfunction codes is provided. Refer to "15.1.1 Error codes: Overview" [p. 24]. Depending on the level of the malfunction code, the code can be reset by pushing the ON/OFF button. If NOT, ask your installer for advice.

i INFORMATION

The preheating/precooling function of the heat reclaim ventilation unit is disabled when it is connected to an EKVDX.

After checking all the items above, if it is impossible to fix the problem yourself, contact your installer and state the symptoms, the complete model name of the unit (with manufacturing number if possible) and the installation date.

7 Relocation

Contact your dealer to remove and reinstall the entire unit. Moving units requires technical expertise.

8 Disposal

! NOTICE

Do NOT try to dismantle the system yourself: dismantling of the system, treatment of the refrigerant, oil and other parts MUST comply with applicable legislation. Units MUST be treated at a specialised treatment facility for reuse, recycling and recovery.

For the installer

9 About the box

Keep the following in mind:

- At delivery, the unit MUST be checked for damage and completeness. Any damage or missing parts MUST be reported immediately to the claims agent of the carrier.
- Bring the packed unit as close as possible to its final installation position to prevent damage during transport.
- Prepare in advance the path along which you want to bring the unit to its final installation position.

9.1 Heat reclaim ventilation unit

9.1.1 To remove the accessories

Models 350+500

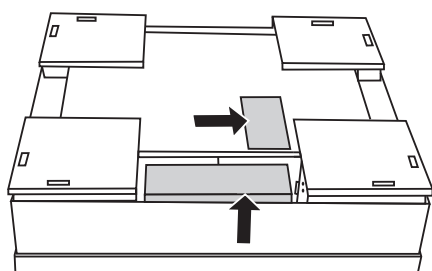

Models 650~1000

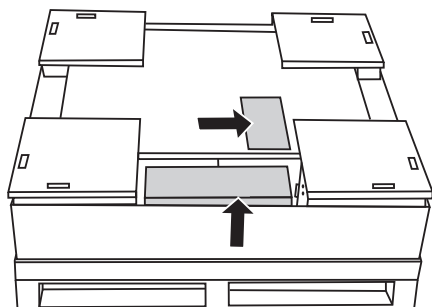

Models 1500+2000

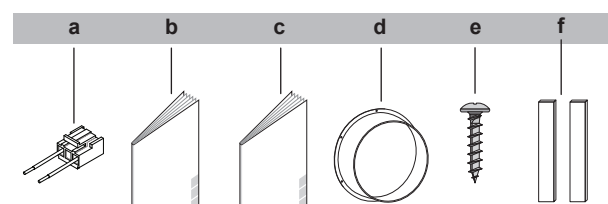
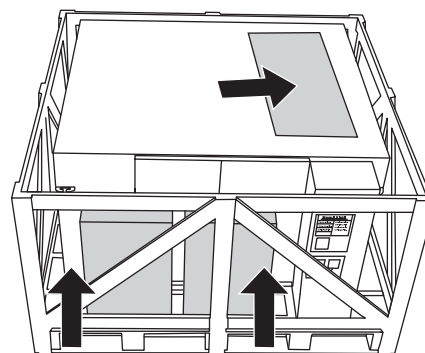

- a Connector for additional external damper
- b General safety precautions
- c Installation and operation manual
- d Duct flanges (models 350~1000 4×, models 1500+2000 8×)
- e Screws (models 350+500 16×, models 650~1000 24×, models 1500+2000 48×)
- f Seal strips for cables (switchbox cable entry)

10 About the heat reclaim ventilation unit

The heat reclaim ventilation unit is intended for indoor installation.

! NOTICE

ALWAYS use the air filters. If the air filters are NOT used, the heat exchange elements can get clogged, possibly causing poor performance and subsequent failure.

11 Unit installation

Operation range	
Outdoor air + room air	
Temperature	-10°C DB~46°C DB
Relative humidity	≤80%
VAM unit location	
Temperature	0°C DB~40°C DB
Relative humidity	≤80%

It is possible that, due to condensation, the paper heat exchanger deteriorates when the unit operates in conditions with high indoor humidity combined with low outdoor temperature. If such combined conditions occur for an extended period of time, the necessary precautions must be taken to prevent condensation. Example: install a preheater to heat up outdoor air.

When the heat reclaim ventilation unit is installed upside down, the minimum allowed outdoor air temperature is 5°C. If this cannot be guaranteed, you **MUST** install a heater to heat up the outdoor air to 5°C.

10.1 About the EKVDX option

The EKVDX option is an airconditioning unit for the pretreatment of incoming supply air from a VAM heat reclaim ventilation unit. For comfort temperature control, it is still required to install a normal indoor unit.

EKVDX units are available:

- for models VAM500~2000J*.
- with refrigerants R32 or R410A.

In case an EKVDX is installed, after setting the field settings on the EKVDX, make sure to set the appropriate field settings on the VAM. See "13.2 Field settings" [p 18].



INFORMATION

When connected to an EKVDX, the minimum airflow during normal operation or during the refrigerant leakage detection is always >240 m³/h.

11 Unit installation

11.1 Preparing the installation site

Do NOT install a heat reclaim ventilation unit or air suction/discharge grille in the following places:

- Places, such as machinery plants and chemical plants, where noxious gases or corrosive components of materials such as acid, alkali, organic solvent and paint are present.
- Places, such as bathrooms, subject to moisture. Moisture can cause electrical shock, electric leakage and other failures.
- Places subject to high temperature or direct flames.
- Places subject to much soot. Soot clings to air filter and heat exchange elements, disabling them.

11.1.1 Installation site requirements for the heat reclaim ventilation unit



CAUTION

See "2 Specific installer safety instructions" [p 2] to make sure this installation complies with all safety regulations.

Service space

See "17.2 Service space" [p 26].

11.2 Preparing the unit



CAUTION

See "2 Specific installer safety instructions" [p 2] to make sure this installation complies with all safety regulations.



INFORMATION

- Flexible ducting with sound insulation is effective to reduce blowing noises.
- When selecting installation materials, consider the required volume of air flow and the acceptable level of noise for that particular installation.
- When room air infiltrates into the ceiling and the temperature and humidity in the ceiling become too high, insulate the metal parts of the unit.
- **ONLY** use the inspection hole to access the inside of the unit.
- The sound pressure level is less than 70 dBA.

11.2.1 To install the optional adapter PCB

For models 350-500-800-1000

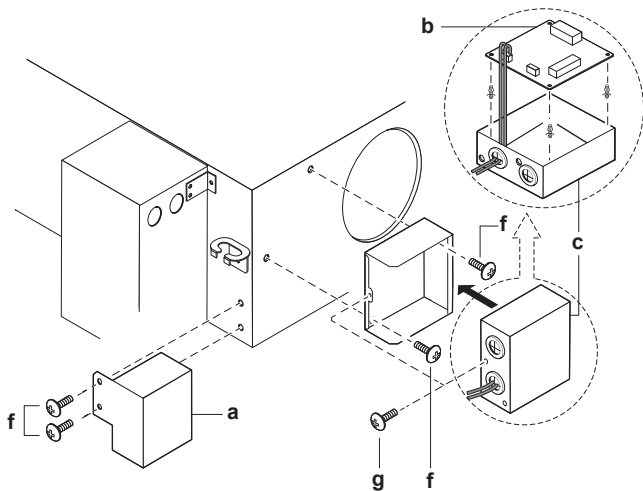

- a BRP4A50A (optional accessory)
- b KRP2A51 (optional accessory)
- c KRP1BA101 (installation box)
- f Screw
- g Screw (supplied with the installation box)

- 1 Remove the screws from the unit.
- 2 Attach the optional adapter PCB (KRP2A51) in the installation box (KRP1BA101).
- 3 Follow the installation instructions provided with the option kits (BRP4A50A, KRP2A51 and KRP1BA101).
- 4 Guide the PCB wire through the dedicated holes and attach it as instructed in "Opening the switch box" in the installer and user reference guide.
- 5 Attach the options to the unit, as shown in the figure.
- 6 After the wires are connected, fasten the switch box cover.

For model 650

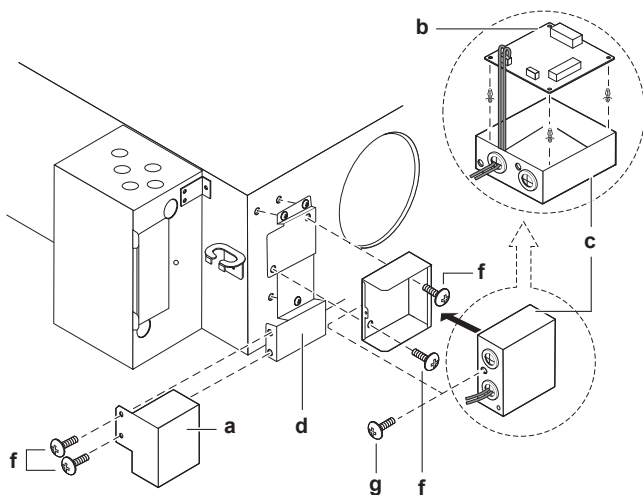

- a BRP4A50A (optional accessory)
- b KRP2A51 (optional accessory)
- c KRP1BA101 (installation box)
- d EKMP65VAM (mounting plate)
- f Screw
- g Screw (supplied with the installation box)

- 1 Remove the screws from the unit.
- 2 Attach the optional mounting plate (EKMP65VAM) to the unit.
- 3 Attach the optional adapter PCB (KRP2A51) in the installation box (KRP1BA101).
- 4 Follow the installation instructions provided with the option kits (BRP4A50A, KRP2A51 and KRP1BA101).
- 5 Guide the PCB wire through the dedicated holes and attach it as instructed in "Opening the switch box" in the installer and user reference guide.
- 6 Attach the options to the optional mounting plate, as shown in the figure.
- 7 After the wires are connected, fasten the switch box cover.

For models 1500+2000

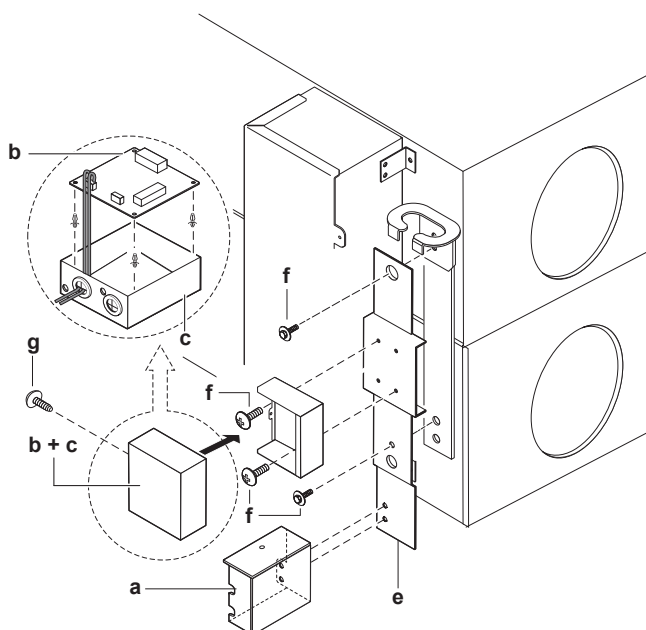

- a BRP4A50A (optional accessory)
- b KRP2A51 (optional accessory)
- c KRP1BA101 (installation box)
- d EKMP65VAM (mounting plate)
- f Screw
- g Screw (supplied with the installation box)

- 1 Remove the screws from the middle of the plate connecting the 2 units.
- 2 Attach the optional mounting plate (EKMPVAM) on top of the plate connecting the 2 units.
- 3 Attach the optional adapter PCB (KRP2A51) in the installation box (KRP1BA101).
- 4 Follow the installation instructions provided with the option kits (BRP4A50A, KRP2A51 and KRP1BA101).
- 5 Guide the PCB wire through the dedicated holes and attach it as instructed in "Opening the switch box" in the installer and user reference guide.
- 6 Attach the options to the optional mounting plate, as shown in the figure.
- 7 After the wires are connected, fasten the switch box cover.

11.2.2 To install the duct flanges

- 1 Position the duct flanges (a) over the duct holes.
- 2 Secure the duct flanges with the provided screws (b) (see accessory bag).

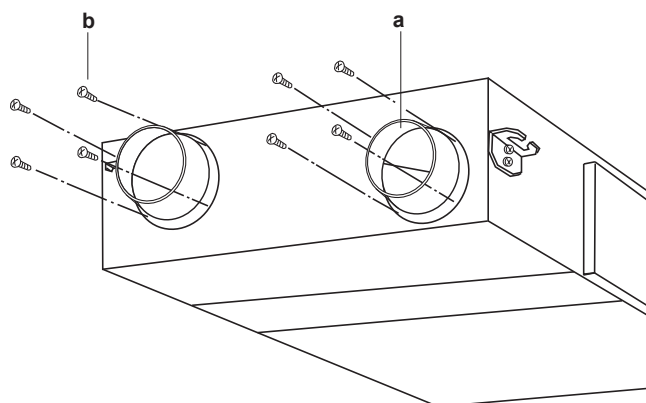

- a Duct flange
- b Screw

Model	Required screws	Duct flanges
VAM350	16	4× Ø200 mm
VAM500	16	4× Ø200 mm
VAM650	24	4× Ø250 mm
VAM800	24	4× Ø250 mm
VAM1000	24	4× Ø250 mm
VAM1500	48	8× Ø250 mm
VAM2000	48	8× Ø250 mm

11.2.3 To install the EKVDX option

See "13.2 Field settings" [p 18].

For more information, see the Installation and operation manual of the EKVDX.

11.3 Unit orientation

The following illustration helps you to install the heat reclaim ventilation unit in the correct position:

11 Unit installation

Normal installation

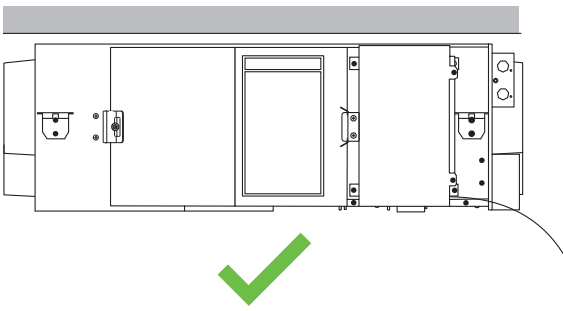

Upside down installation

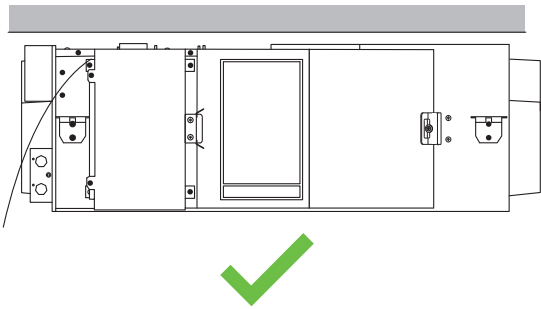

Vertical installation

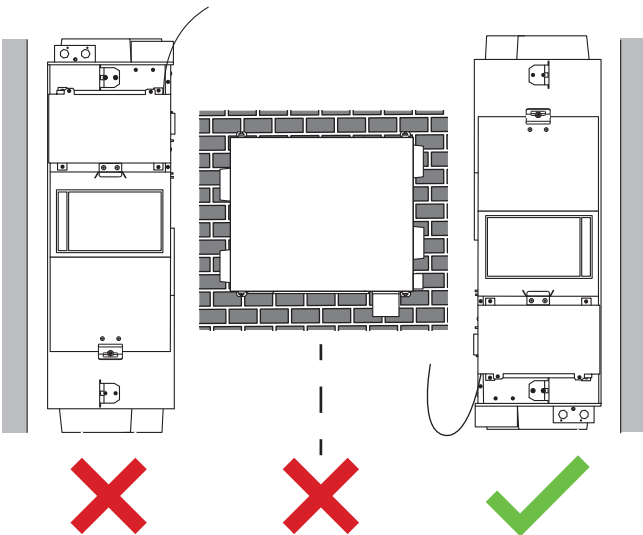

INFORMATION

When the unit is installed vertically, the installer **MUST** provide a support under the unit to distribute the weight of the unit between the support and the installation bolts in the wall.



NOTICE

When the heat reclaim ventilation unit is installed vertically in low outdoor temperature conditions, dewing or freezing may occur. If such operating conditions are to be expected, take the appropriate precautions, e.g. install an electrical heater.

Installation tips

- Installing the unit upside down allows for common use of the inspection hole, thus reducing the required maintenance space. For example, if 2 units are installed closely together, only 1 inspection hole is required for maintaining or replacing filters, heat exchange elements,...

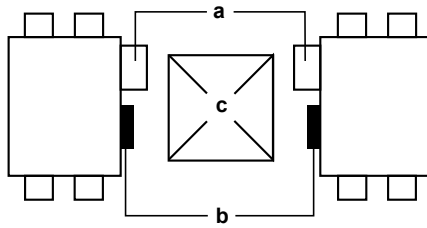

- a Control box
- b Service cover
- c Inspection hole

- Keep in mind that the ceiling hooks **MUST** be rotated 180° when the heat reclaim ventilation unit is installed upside down (see the figure).

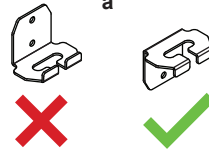
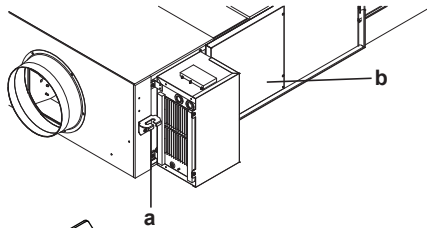

- a Ceiling hook
- b Service cover

11.4 To install the anchor bolts

Prerequisite: Before installing the anchor bolts, remove any foreign objects, such as vinyl and paper, from the inside of the fan housing.

- 1 Install the anchor bolts (M10 to M12).
- 2 Pass the metal suspension brackets over the anchor bolts.
- 3 Secure the anchor bolts with washer and nut.

For models 350~1000

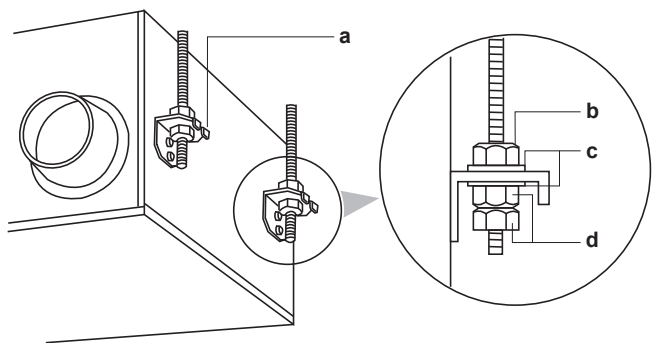

For models 1500+2000

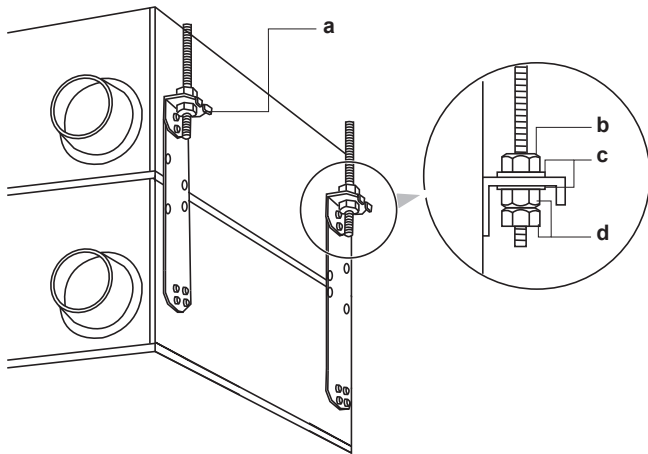

- a Ceiling hook
- b Nut
- c Washer
- d Double nut



NOTICE

ALWAYS hang up the unit by its suspension brackets.

11.5 Duct connections

Do NOT connect the ducts as follows:

Extreme bend. Do NOT bend the duct more than 90°.	
Multi bend	
Reduced diameter. Do NOT reduce the duct diameter.	

- The minimum bend radius for flexible ducts is as follows: $(\text{Øduct} / 2) \times 1.5$
- To prevent air leakage, wind aluminium tape around the section where the duct flanges and the ducts are connected.
- Install the opening of the supply air as far as possible from the opening of the room air.
- Use ducts with a diameter that fits the unit model. See the data book.
- Install the two outdoor ducts with a downward slope (minimum 1:50) to prevent entry of rain water. Also provide insulation for both ducts, to prevent dew formation. (Insulation material: 25 mm thick glass wool)
- If the temperature and humidity levels inside the ceiling are always high, install ventilation inside the ceiling.
- Insulate the duct and the wall electrically when a metal duct has to penetrate the metal lattice and wire lattice or the metal lining of a wooden structure wall.
- Install the ducts in such a way that the wind CANNOT blow inside the ducting.
- All 4 ducts MUST have a length ≥ 1.5 m (exception: VAM in combination with optional EKVDX, see EKVDX operation and installation manual).

Models 350~1000

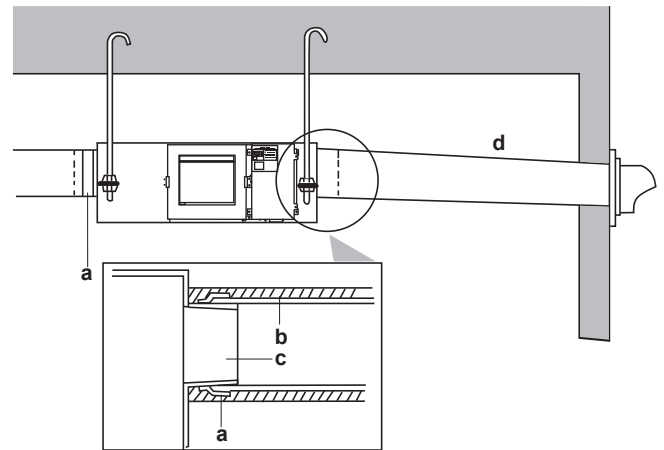

Models 1500+2000

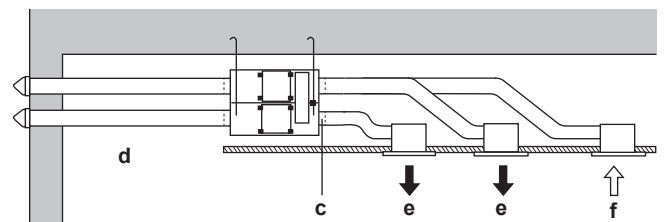

- a Aluminium tape (field supply)
- b Insulation material (field supply)
- c Duct flange (accessories)
- d Slope minimum 1:50
- e Supply air
- f Room air



INFORMATION

For more information about duct connections in combination with an EKVDX module, refer to the installer and user reference guide of the EKVDX unit.

12 Electrical installation



CAUTION

See "2 Specific installer safety instructions" [p 2] to make sure this installation complies with all safety regulations.

12.1 Component electrical specifications

Model	350	500	650	800	1000	1500	2000
Power supply							
Voltage	220~240 V \pm 10%.						
Frequency	50/60 Hz						
MCA (A)	1.56	2.08	2.80	4.39	4.90	8.78	9.80
MFA (A)	6	6	6	6	6	16	16
Fan motor							
P (kW)	0.08×2	0.08×2	0.11×2	0.21×2	0.21×2	0.21×4	0.21×4
FLA (A)	0.62×2	0.83×2	1.12×2	1.76×2	1.96×2	1.76×4	1.96×4

- MCA Minimum Circuit Amps
- MFA Maximum Fuse Amps
- P Motor Rated Load
- FLA Full Load Amps



NOTICE

The power supply MUST be protected with the required safety devices, i.e. a main switch, a slow blow fuse on each phase and an earth leakage protector in accordance with the applicable legislation.

12 Electrical installation

NOTICE

In the power supply line, ALWAYS install a residual current device (RCD) with an instantaneous action. The installed RCD MUST comply with the national wiring regulation.

NOTICE

See the data book for more details.

12.2 Specifications for field supplied fuses and wires

Power supply wiring	
Field supplied fuses	6 A/16 A
Wire	H05VV-U3G
Size	Wire size MUST comply with the applicable legislation.
Interconnection wiring	
Wiring	Sheathed wire (2 wire)
Size	0.75~1.25 mm ²

Precautions

When connecting more than one wire to the power supply wiring, use a 2 mm² (Ø1.6 mm) gauge wire.

When using 2 power wires of a gauge greater than 2 mm² (Ø1.6 mm), branch the line outside the terminal board of the unit, in accordance with electrical equipment standards. The branch MUST be sheathed to provide a degree of insulation equal to or greater than the power supply wiring itself.

Limit the total current of crossover wiring between indoor units to less than 12 A.

Do NOT connect wires of different gauge to the same grounding terminal. Loose connections may reduce the protection.

For the controller wiring, refer to the installation manual of the controller delivered with the controller.

Wiring example

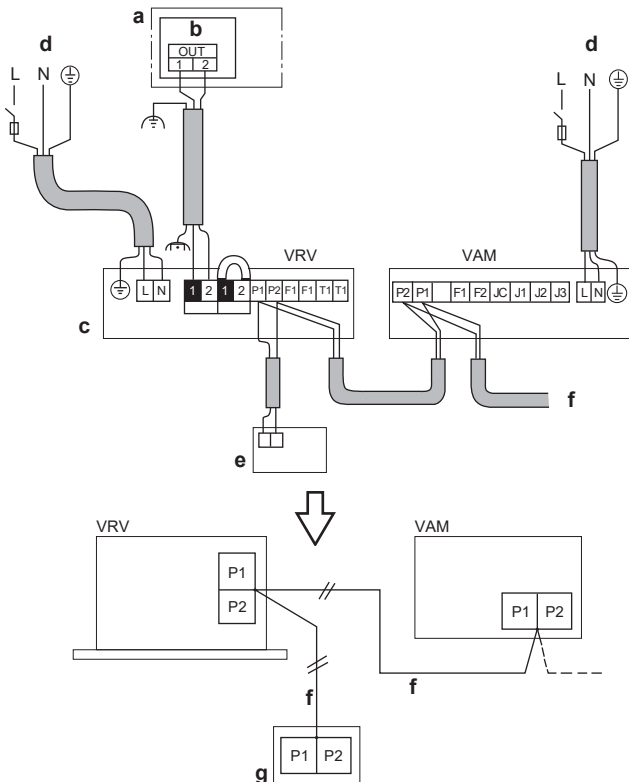

a Outdoor unit/BS unit

- b Switch box
- c Indoor unit
- d Power supply 220-240 V~50/60 Hz
- e Controller for VRV
- f Interconnection wiring
- g Controller for VAM
- VRV VRV indoor unit
- VAM VAM heat reclaim ventilation unit



WARNING

The VAM and the EKVDX indoor unit MUST share the same electrical safety devices and power supply.

12.3 Opening the switch box



CAUTION

Before opening the cover, be sure to turn off the power switches of the main units and other devices connected to the main units.

- Remove the screws that secure the cover and open the switch box.
- Secure the power supply cable and the control wire with a tie wrap, as shown in the figures.

Models 350~650

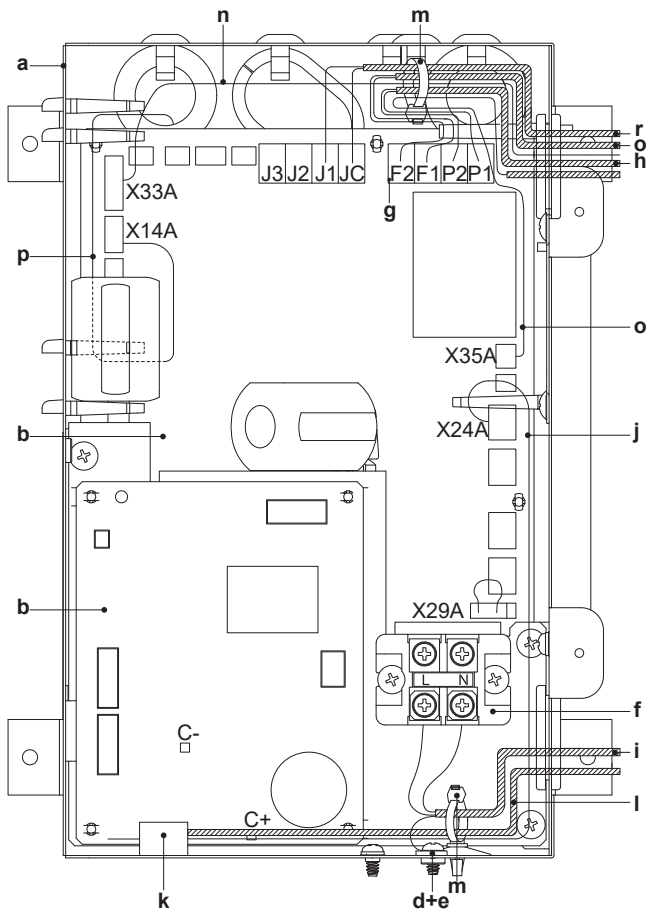

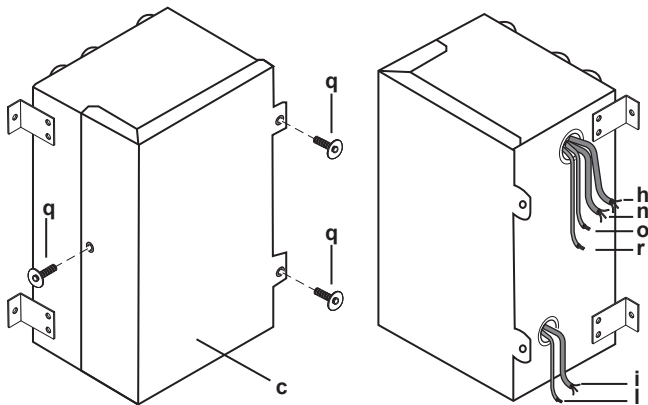
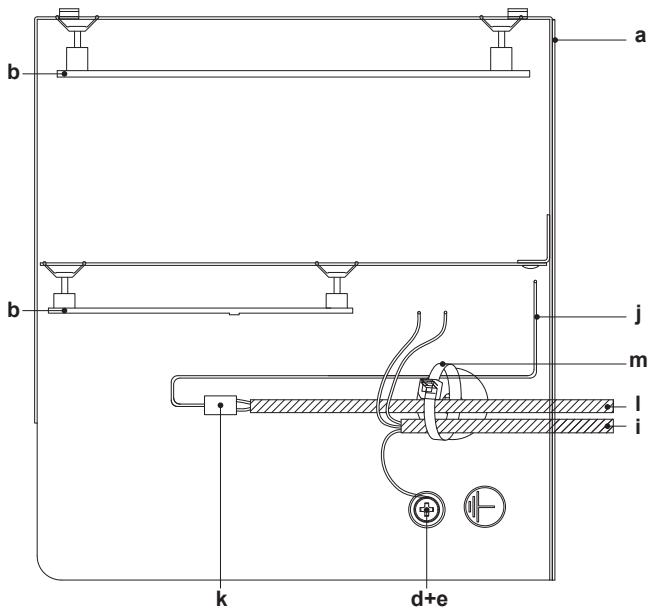

- a Switch box
- b PCB
- c Switch box cover
- d Securing screw and washer
- e Grounding terminal
- f Terminal board
- g Interconnection wiring terminal board (P1, P2, F1, F2)
- h Interconnection wiring (to optional controller)
- i Power supply cable
- j Wires for connection of additional external damper (supplied accessory)
- k Insulated splices-closed barrel connector (0.75 mm²) (field supply)
- l Double or reinforced insulated flexible cable (0.75 mm²) to external damper (field supply)
- m Tie wrap (field supply)
- n BRP4A50A (optional accessory)
- o KRP2A51 (optional accessory)
- p CO₂ sensor (optional accessory)
- q Tapping screw
- r Wires for fresh-up operation

Models 800+1000

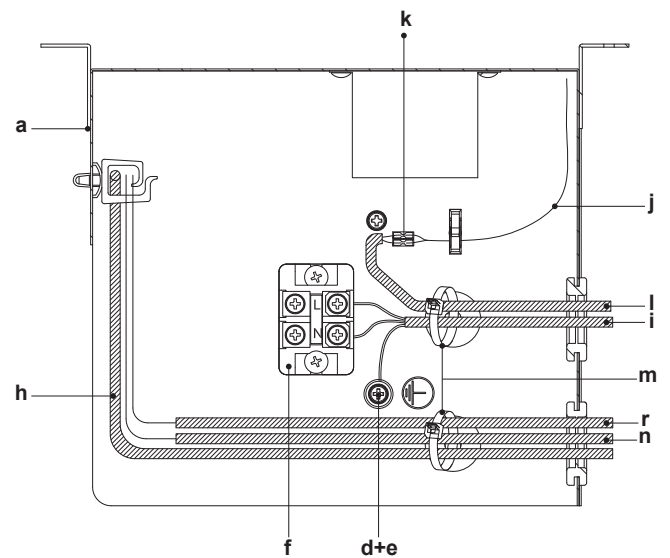
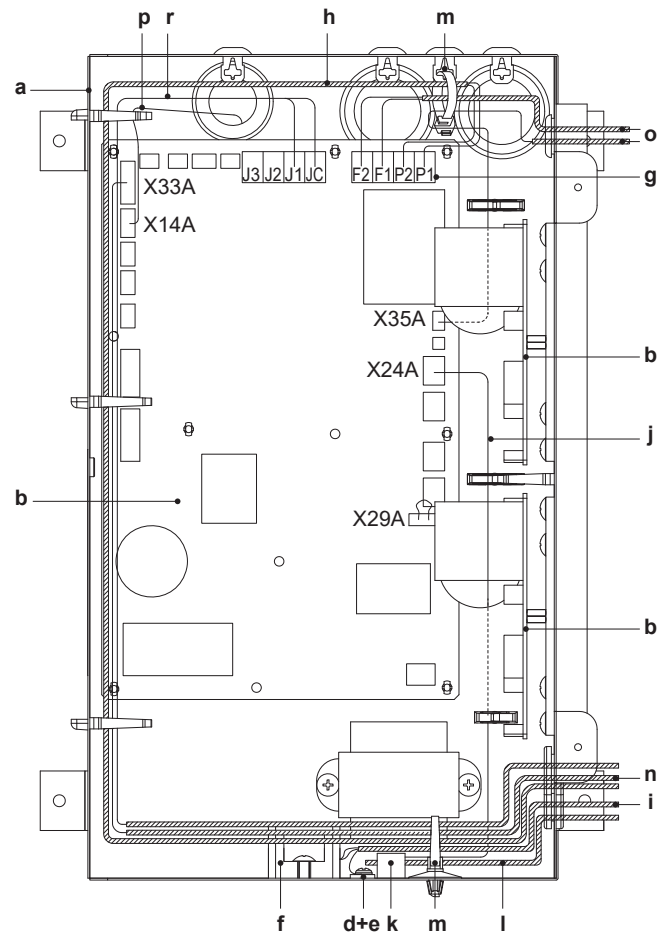

12 Electrical installation

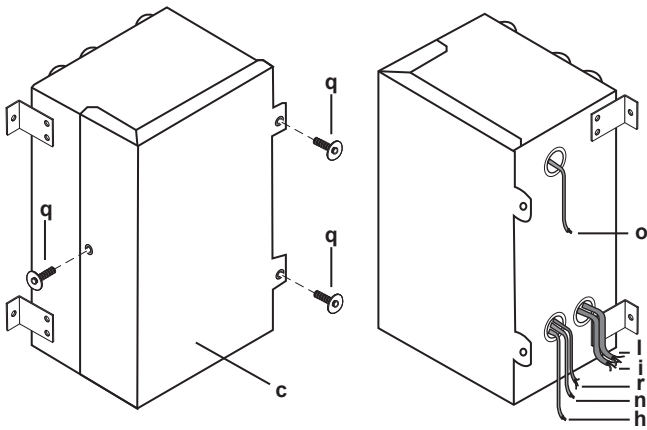

- a Switch box
- b PCB
- c Switch box cover
- d Securing screw and washer
- e Grounding terminal
- f Terminal board
- g Interconnection wiring terminal board (P1, P2, F1, F2)
- h Interconnection wiring (to optional controller)
- i Power supply cable
- j Wires for connection of additional external damper (supplied accessory)
- k Insulated splices-closed barrel connector (0.75 mm²) (field supply)
- l Double or reinforced insulated flexible cable (0.75 mm²) to external damper (field supply)
- m Tie wrap (field supply)
- n BRP4A50A (optional accessory)
- o KRP2A51 (optional accessory)
- p CO₂ sensor (optional accessory)
- q Tapping screw
- r Wires for fresh-up operation

Models 1500+2000

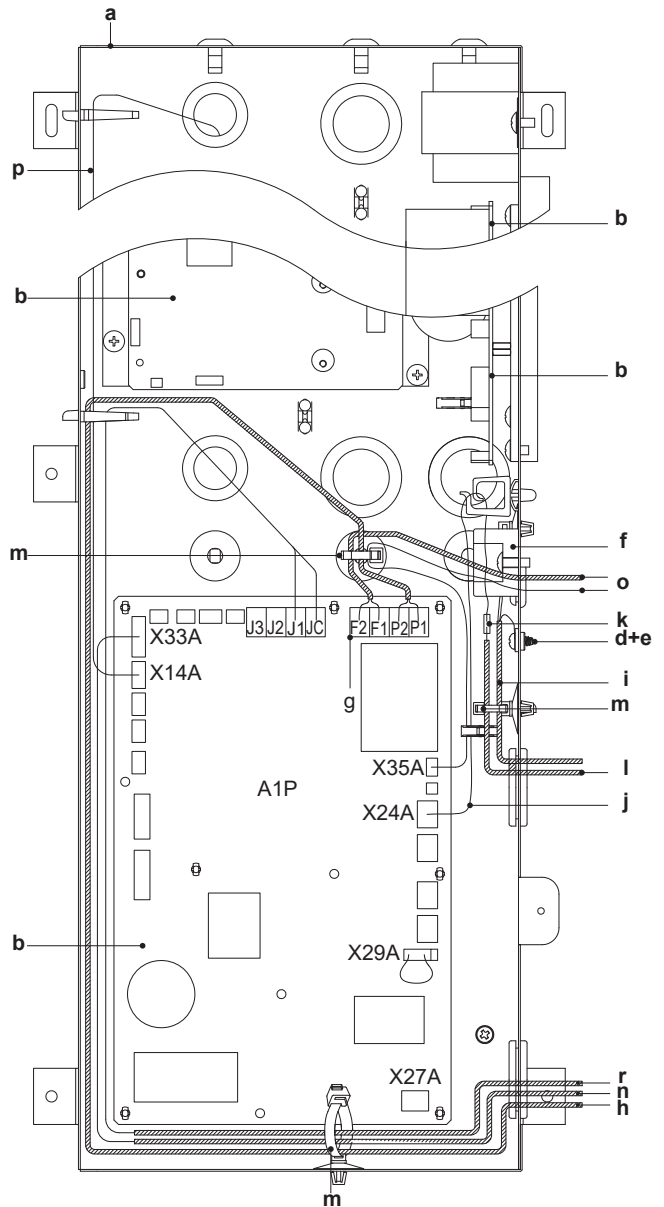

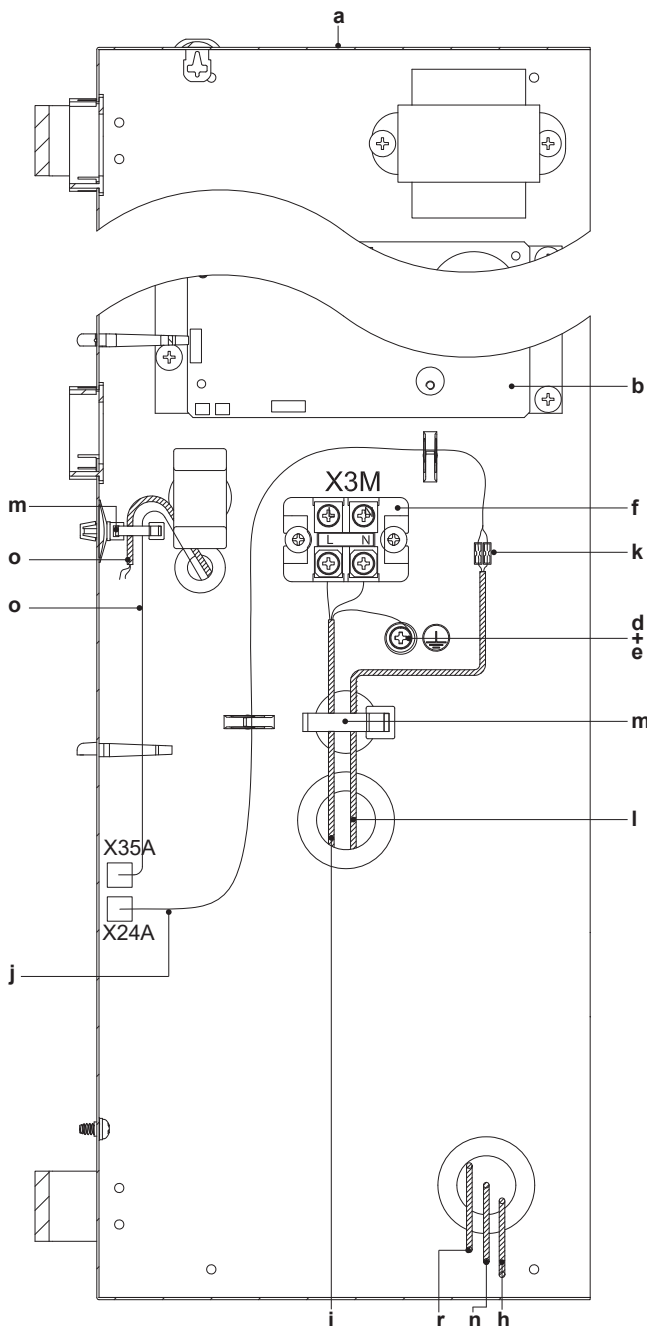

- e Grounding terminal
- f Terminal board
- g Interconnection wiring terminal board (P1, P2, F1, F2)
- h Interconnection wiring (to optional controller)
- li Power supply cable
- j Wires for connection of additional external damper (supplied accessory)
- k Insulated splices-closed barrel connector (0.75 mm²) (field supply)
- l Double or reinforced insulated flexible cable (0.75 mm²) to external damper (field supply)
- m Tie wrap (field supply)
- n BRP4A50A (optional accessory)
- o KRP2A51 (optional accessory)
- p CO₂ sensor (optional accessory)
- q Tapping screw
- r Wires for fresh-up operation

12.4 Electrical connections for additional field supplied damper

An external damper prevents the intake of outdoor air when the VAM is switched off.

The VAM main PCB provides a contact for an external damper.

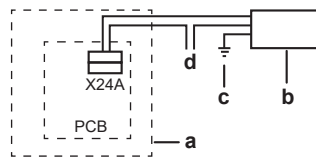

- a VAM
- b External damper
- c External damper earthing
- d Power source



CAUTION

Follow the instructions below carefully.

Required electrical connections

Connect one end of the accessory wire to the X24A connector on the PCB and the other end to the wire leading to the external damper via an insulated splices-closed barrel connector (0.75 mm²).

The electrical circuit requires a current protection of 3 A and a maximum voltage of 250 V.

X24A will close the contact when the VAM fan starts operating and it will open the contact when the fan is stopped.

12.5 To connect the electrical wiring



WARNING

Do NOT extend the power supply or the interconnection cable by using wire connectors, wire connection clamps, taped wires, extension cords.

These can cause overheating, electric shock or fire.



WARNING

The VAM and the EKVDX indoor unit MUST share the same electrical safety devices and power supply.

- 1 **Power supply cable:** Route the cable through the frame and connect the wires to the terminal block (L, N, earth).
- 2 Secure the power supply with the power supply clamp, as shown in "Opening the switch box" in the installer and user reference guide.
- 3 **Interconnection cable(s):** Route the cable(s) through the frame, connect the wires to the terminal block (P1, P2).

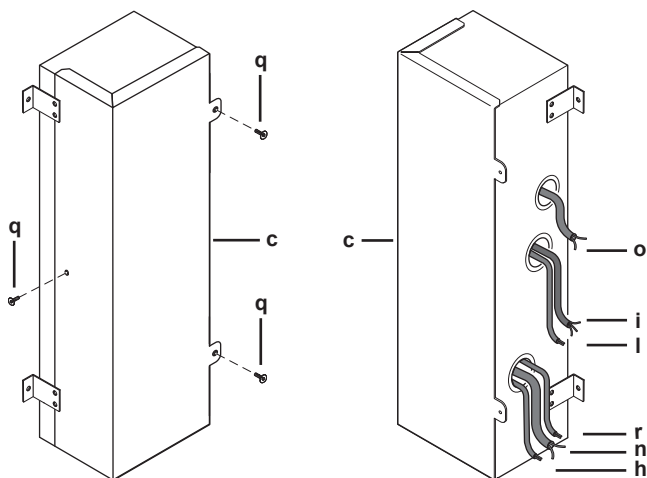

- a Switch box
- b PCB
- c Switch box cover
- d Securing screw and washer

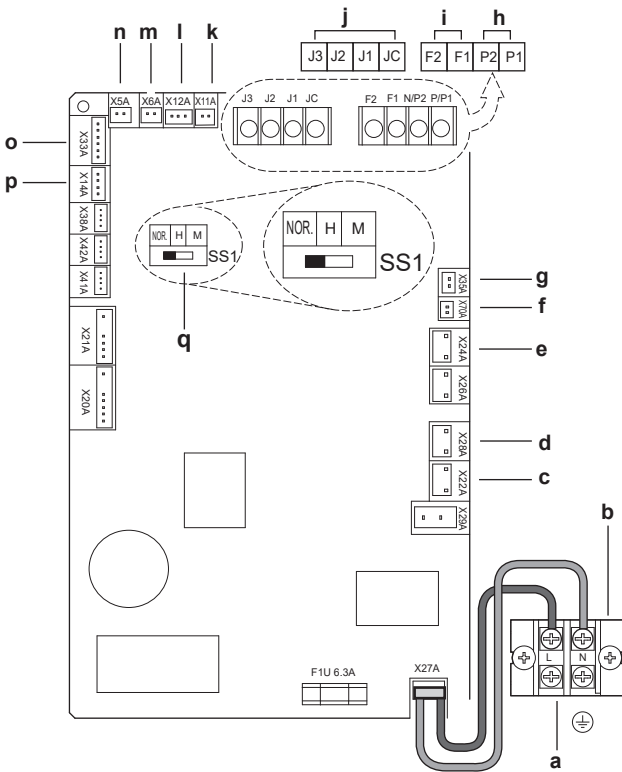

- a Power supply
- b Terminals
- c Bypass damper
- d Bypass damper (only models 1500+2000 bottom unit)
- e External damper (field supply)
- f Fan communications
- g KRP2A51 (option)
- h Controller
- i Central control
- j External input
- k Outdoor air thermistor
- l Indoor air thermistor
- m Bypass damper (only models 1500+2000 bottom unit)
- n Bypass damper
- o BRP4A50A (optional accessory)
- p CO₂ sensor
- q Factory setting (No operation if setting is changed)



WARNING

If a gap is present at the cable entry, wrap the cable (or cables) with the sealing material from the accessory bag. This will prevent small objects (such as children's fingers, ... etc.) as well as fluid droplets from entering the unit.

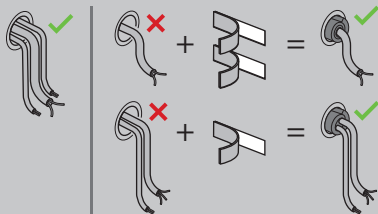

NOTICE

Factory settings: Do NOT change the switch settings when a controller is connected. SS1 is a setting switch to operate the unit without controller. Changing the switch setting when a controller is connected will stop the unit from operating normally. Keep the switch on the PCB in the factory setting position.

13 Configuration

13.1 To change settings

The heat reclaim ventilation unit settings can be adjusted using the controller of either the heat reclaim ventilation unit or the air conditioner.

The settings (format: e.g. 19(29)-1-02), that are used in this chapter are composed of 3 parts, divided by "-":

- Mode number: e.g. 19(29), where 19 is the mode number for group settings and 29 is the mode number for individual settings.
- Switch number: e.g. 1
- Position number: e.g. 02

Initial settings

- Mode numbers 17, 18, and 19: group control of heat reclaim ventilation units.



NOTICE

Field setting mode numbers 17, 18 and 19 CANNOT be used with EKVDX indoor units.

- Mode numbers 27, 28, and 29: individual control or when operating with the optional EKVDX units.

Case 1: Change settings with BRC1E53

Make sure that the switch box lid on the heat reclaim ventilation unit is closed.

- 1 Briefly press a button to turn on the screen light.
 - 2 Press and hold the Cancel button (a) for at least 4 seconds to enter the Service Settings menu.
 - 3 Go to Field Settings with the Up/Down buttons and press the Menu/Enter button (b).
 - 4 Press the Left/Right buttons to highlight the number under Mode.
 - 5 Press the Up/Down buttons to select the required mode number.
- Result:** From mode 20 and up, you also have to select a unit number for individual control.
- 6 Use the Left/Right buttons to highlight the number under Unit No..
 - 7 Use the Up/Down buttons to select an indoor unit number. Selecting a unit number is NOT necessary when configuring the entire group.
 - 8 Use the Left/Right buttons to select a switch number (0 to 15) to change.

In case of individual settings:

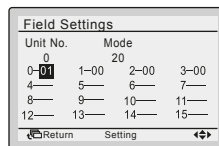

In case of group settings:

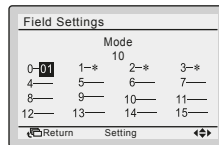

- 9 Use the Up/Down buttons to select the required position number.
- 10 Press the Menu/Enter (b) button and confirm the selection with Yes.

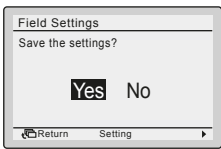

11 After you have completed all changes, press the Cancel button (a) twice to return to the normal mode.

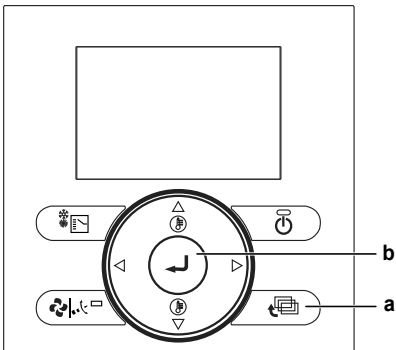

- a Cancel button
- b Menu/Enter button

Case 2: Change settings with BRC301B61

Make sure that the switch box lid on the heat reclaim ventilation unit is closed.

- 1 With the unit in normal mode, press the Inspection/Trial button (a) for more than 4 seconds to enter the local setting mode.
- 2 Use the Ventilation mode button (b) and the Airflow rate button (c) to select a mode number.

Result: The code display is blinking.

- 3 To configure settings for individual units under group control, press the Timer setting on/off button (d) and select the number of the unit that you want to configure.
- 4 To select the setting switch number, press the top section of the Timer button (e). To select the setting position number, press the lower section of the Timer button (e).

- 5 Press the Program/Cancel button (f) once to enter the setting.

Result: The code display stops blinking and lights up.

- 6 Press the Inspection/Trial button (a) to return to normal mode.

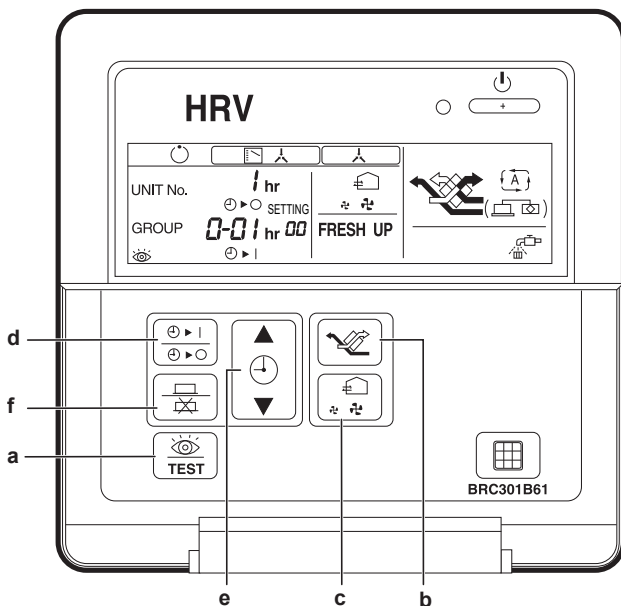

- a Inspection/Trial button
- b Ventilation mode button
- c Airflow rate button
- d Timer setting on/off button

- e Timer button
- f Program/Cancel button

i INFORMATION

Setting 18(28)-11 CANNOT be selected with this controller.

Case 3: Change settings with BRC1H

i INFORMATION

Please refer to the Installer and user reference guide of the BRC1H remote controller.

Case 4: Change settings with BRC1K

i INFORMATION

Please refer to the installer and user reference guide of the BRC1K remote controller.

13.2 Field settings

Mode	SW	SW description	SW position ^(a)														
			01	02	03	04	05	06	07	08	09	10	11	12	13	14	15
17 (27)	0	Filter cleaning time	±2500 hours	±1250 hours	—	—	—	—	—	—	—	—	—	—	—	—	—
	1	Nighttime free cooling timer (after stop) ^(b)	OFF	ON after 2 hours	ON after 4 hours	ON after 6 hours	ON after 8 hours	—	—	—	—	—	—	—	—	—	—
	2	Precool/preheat ^(c)	OFF	ON	—	—	—	—	—	—	—	—	—	—	—	—	—
	3	Precool/preheat duration ^(c)	30 minutes	45 minutes	60 minutes	—	—	—	—	—	—	—	—	—	—	—	—
17 (27)	4	Initial fan speed ^(d)	High	Ultra-high	—	—	—	—	—	—	—	—	—	—	—	—	—
	5 ^(a)	Yes/No setting for duct connection with VRV system	Without duct	With duct	Without duct	Without duct	Without duct	Without duct	Without duct	Without duct	Without duct	Without duct	Without duct	Without duct	Without duct	Without duct	Without duct
	6	Fan setting for cold areas ^(f)	—	—	Stop/Stop	Low/Low	Stop/stop	Low/Low	Stop/stop	Low/Low	Stop/stop	Low/Low	Stop/stop	Low/Low	Stop/stop	Low/Low	Stop/stop
	7	Fan operation during defrost/oil return/hot start ^(f)	—	—	Stop/Stop	Stop/Stop	Stop/Stop	Stop/—	Stop/—	Stop/—	Stop/—	Stop/—	Stop/—	Stop/—	Stop/—	Stop/—	Stop/—
18 (28)	6	Nighttime free cooling (fan settings) ^(g)	High	Ultra-high	—	—	—	—	—	—	—	—	—	—	—	—	—
	7	Target temperature for independent nighttime free cooling ^(g)	18°C	19°C	20°C	21°C	22°C	23°C	24°C	25°C	26°C	27°C	28°C	29°C	30°C	—	—
	8	Central zone link	No	Yes	—	—	—	—	—	—	—	—	—	—	—	—	—
	9	Preheat time extension ^(c)	0 minutes	30 minutes	60 minutes	90 minutes	—	—	—	—	—	—	—	—	—	—	—
18 (28)	0	External signal ^(h) JCU2	Last command	Priority on external input	Priority on operation	Disable nighttime free cooling/Perform forced stop	—	—	—	—	—	—	—	—	—	—	—
	1	Direct power ON	OFF	ON	—	—	—	—	—	—	—	—	—	—	—	—	—
	2	Auto restart ^(h)	OFF	ON	—	—	—	—	—	—	—	—	—	—	—	—	—
	3	Output signal to external damper (X24A)	—	—	Damper output (fan operation)	Damper output (fan operation)	—	—	—	—	—	—	—	—	—	—	—
18 (28)	4	Indication of ventilation mode	ON	OFF	—	—	—	—	—	—	—	—	—	—	—	—	—
	6	Automatic ventilation air flow mode	Linear	—	Fixed A	Fixed B	—	—	—	—	—	—	—	—	—	—	—
	7	Fresh-up mode	Supply – no indication	Exhaust – no indication	Supply – indication	Exhaust – indication	—	—	—	—	—	—	—	—	—	—	—
	8	External input terminal function selection ⁽ⁱ⁾ (JCU/J1)	Fresh-up	Error output	Error output and stop operation	Forced off	Fan forced off	Air-flow up	—	—	—	—	—	—	—	—	—
18 (28)	9	BRP4A50A output switching selection (between X3 and X4)	Heater output	Error output	Fan output (Low/High/Ultra-high)	Fan output (High/Ultra-high)	Fan output (Ultra-high)	Fan output (Low/High/Ultra-high)	—	—	—	—	—	—	—	—	—
	10	(between X1 and X2)	Operation output	Operation output	Operation output	Operation output	—	—	—	—	—	—	—	—	—	—	—
	11	EKVDX connected? ^(j)	No	Yes	—	—	—	—	—	—	—	—	—	—	—	—	—
	13	Filter contamination check	No action	Reset filter check	Force filter check	—	—	—	—	—	—	—	—	—	—	—	—
19 (29)	13	Cooling set point (with EKVDX)	13°C	15°C	16°C	17°C	18°C	19°C	20°C	21°C	22°C	23°C	24°C	25°C	26°C	28°C	30°C
	14	Heating set point (with EKVDX)	24°C	26°C	27°C	28°C	29°C	30°C	31°C	32°C	33°C	35°C	37°C	39°C	41°C	43°C	45°C
	0	Pressure-based check with fan step 1-15	Pressure-based check with fan step 1-15	Pressure-based check with new fan step	Timer based check	Filter contamination target detection with fan step 1-15	Auto ESP selection and filter contamination target detection with new fan step	—	—	—	—	—	—	—	—	—	—
	0	Filter contamination inspection ^(k)	Pressure-based check with fan step 1-15	Pressure-based check with new fan step	Run 1/10 (27 min. OFF/3 min. ON)	Run 1/6 (25 min. OFF/5 min. ON)	Run 1/4 (22.5 min. OFF/7.5 min. ON)	Step 6	Step 6	Run 1/2 (15 min. OFF/15 min. ON)	Step 7	Step 7	Step 7	Step 7	Step 7	Step 7	Step 7
19 (29)	1	Low lap ^(l)	OFF	Run 1/15 (28 min. OFF/2 min. ON)	Run 1/10 (27 min. OFF/3 min. ON)	Run 1/6 (25 min. OFF/5 min. ON)	Step 4	Step 4	Run 1/2 (15 min. OFF/15 min. ON)	Step 5	Step 5	Step 5	Step 5	Step 5	Step 5	Step 5	Step 5
	2	Supply fan step ^(m)	Step 1	Step 2	Step 3	Step 4	Step 5	Step 6	Step 7	Step 8	Step 9	Step 10	Step 11	Step 12	Step 13	Step 14	Step 15
	3	Exhaust fan step ^(m)	Step 1	Step 2	Step 3	Step 4	Step 5	Step 6	Step 7	Step 8	Step 9	Step 10	Step 11	Step 12	Step 13	Step 14	Step 15
	4	24-hour ventilation ⁽ⁿ⁾	OFF	Run 1/15 (28 min. OFF/2 min. ON)	Run 1/10 (27 min. OFF/3 min. ON)	Run 1/6 (25 min. OFF/5 min. ON)	Run 1/4 (22.5 min. OFF/7.5 min. ON)	Run 1/3 (20 min. OFF/10 min. ON)	Run 1/2 (15 min. OFF/15 min. ON)	Step 1	Step 1	Step 1	Step 1	Step 1	Step 1	Step 1	Step 1

Mode	SW	SW description	SW position ^(a)														
			01	02	03	04	05	06	07	08	09	10	11	12	13	14	15
19(29)	5	Humidification ON/OFF setting	ON	OFF	—	—	—	—	—	—	—	—	—	—	—	—	—
	7	Reference concentration shift for ventilation air flow control (ppm)	0	+200	+400	+600	-200	-400	-600	—	—	—	—	—	—	—	—
1A	8	Stop ventilation by automatic ventilation air flow control	Allowed	NOT allowed	Allowed	NOT allowed	—	—	—	—	—	—	—	—	—	—	—
	8	Fan residual operation	OFF	OFF	Heater operation	Heater operation	—	—	—	—	—	—	—	—	—	—	—
1A	9	Normal ventilation tap on automatic ventilation air flow control	—	—	—	—	Control by CO ₂ sensor	—	—	—	—	—	—	—	—	—	—
	15	R32 safety system ^(b)	OFF	ON	—	—	—	—	—	—	—	—	—	—	—	—	—
1A	0	Fresh-up operation ^(c)	OFF	ON	—	—	—	—	—	—	—	—	—	—	—	—	—

- ^(a) Factory settings are marked with a grey background.
- ^(b) In case VAM and EKVDX are combined and the R32 safety system of the VAM is active, the nighttime free cooling is disabled.
- ^(c) The preheating/precooling function of the heat reclaim ventilation unit is disabled when it is connected to an EKVDX.
- ^(d) When connected to an EKVDX, set to 2 or 4.
- ^(e) When connected to an EKVDX, 17(27)-5 can be set to 1, 3, 4, 7 or 8.
- ^(f) Fan operation when heater thermostat is OFF. Supply air/Exhaust air, e.g. Low/Low means: Supply air low/Exhaust air low.
- ^(g) When connected to an EKVDX, JC/J2 cannot be used. Set to 18(28)-0-7. Instead, use T1 T2 of the EKVDX. See the EKVDX Installation and operation manual.
- ^(h) When connected to an EKVDX, do not change the default settings.
- ⁽ⁱ⁾ When connected to an EKVDX, JC/J1 cannot be used. Instead, use T1 T2 of the EKVDX. See the EKVDX Installation and operation manual.
- ^(j) When connected to an EKVDX, set to 18(28)-10-2.
- ^(k) When connected to an EKVDX, a filter contamination check is performed automatically and is timer based. This setting CANNOT be done with BRC301B61
- ^(l) When connected to an EKVDX, this field setting will always be OFF.
- ^(m) See the technical data book for pressure drop curves and selection of fan curves (step 1 to 15).
- ⁽ⁿ⁾ When connected to an EKVDX, setting 2 (safety ON) is required in case R32 refrigerant is used. Setting 1 (safety OFF) is required in case R410A refrigerant is used.

Note: When connected to an EKVDX, SS1 cannot be used. Instead, use T1 T2 of the EKVDX. See the EKVDX Installation and operation manual.

Note: The setting modes are mentioned as group settings, between parentheses are the setting modes for individual unit control or when connected to the EKVDX option. Group number setting for central controller: mode 00=group controller / mode 30=individual controller. For the setting procedure, see "Group number setting for central control" in the operation manual of either the ON/OFF controller or the central controller.

13 Configuration

13.3 Settings for all configurations

Setting 17(27)-4: First choose the fan speed. Set it to high or ultra-high.

Flow "All other system configurations" is not applicable when combining VAM with EKVDX. Check the field settings for both units to make sure the combination of VAM and EKVDX is operational

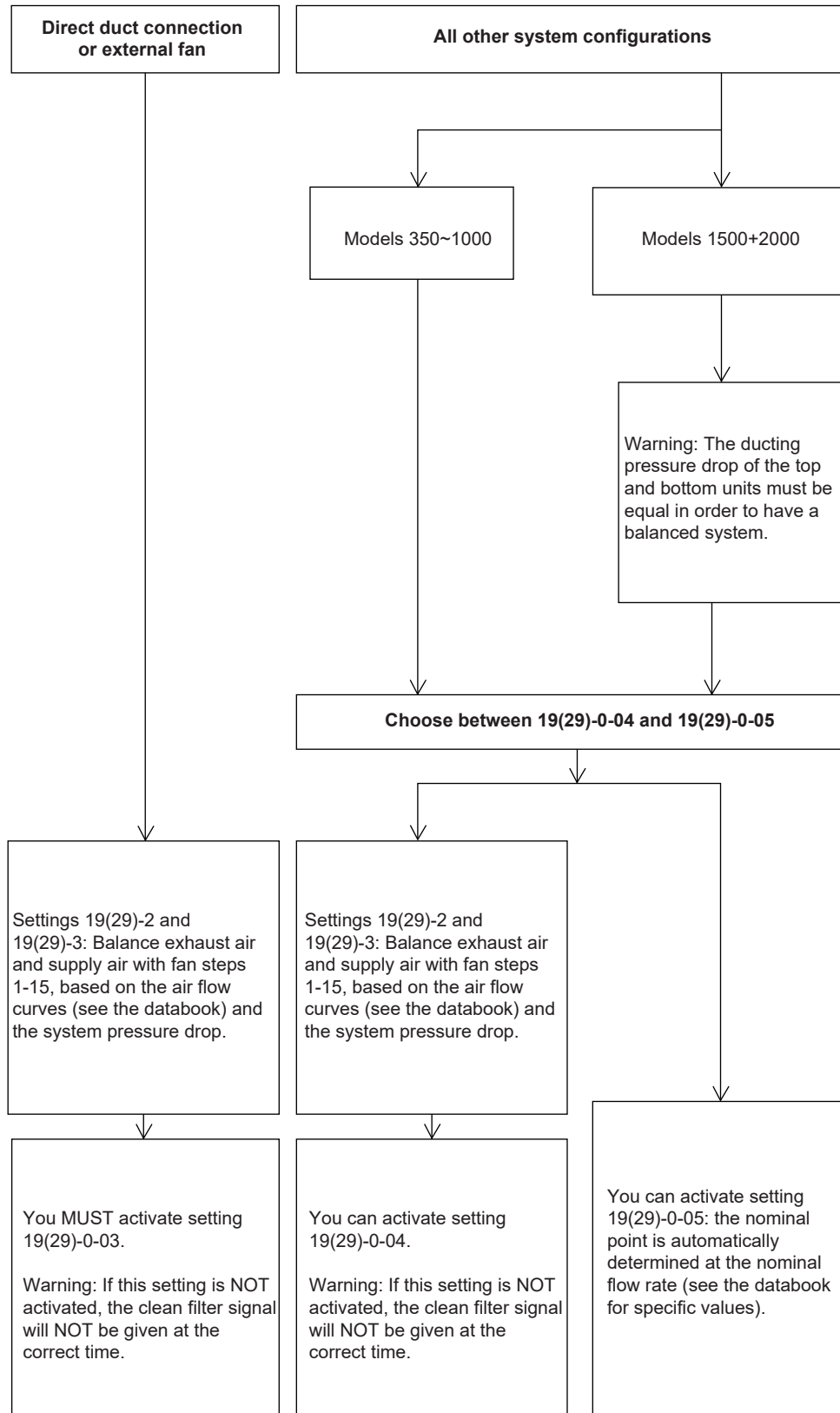

13.3.1 About settings 19(29)-0-04 and 19(29)-0-05

- When you have configured setting 19(29)-0-04 successfully, the system automatically changes it to setting 19(29)-0-01.
- When you have configured setting 19(29)-0-05 successfully, the system automatically changes it to setting 19(29)-0-02.



NOTICE

If the ducting is changed, install clean filters and reconfigure setting 19(29)-0-04 or 19(29)-0-05. Otherwise the signal to clean the filters will come too soon. Do NOT adjust the dampers when setting 19(29)-0-04 or 05 is activated.

- If the controller is switched off while activating setting 19(29)-0-04 or 19(29)-0-05, configuration is aborted. When you switch the controller back on, the function starts from the beginning.
- Setting 19(29)-0-04 takes between 1 and 6 minutes to complete. You can check if the setting was completed successfully by checking if the field setting is changed to 0-01.
- Setting 19(29)-0-05 takes between 3 and 35 minutes to complete. You can check if the setting was completed successfully by checking if the field setting is changed to 0-02.



INFORMATION

While activating setting 19(29)-0-04 and 19(29)-0-05, the unit is set to heat recovery and the fan is on high or ultra high. After configuration, the settings are returned to what they were before the configuration.

- These settings can ONLY be activated with clean filters.
- For models 1500+2000, make sure that the ducting pressure drop of the top and bottom units is balanced.
- The function starts as soon as it is selected and the controller is on.
- Setting 19(29)-0-04 CANNOT be configured if the outside temperature is $\leq -10^{\circ}\text{C}$, which is out of the operation range.
- Setting 19(29)-0-05 CANNOT be configured if the outside temperature is $\leq 5^{\circ}\text{C}$. In this case, error 65-03 is shown and the unit stops working. Change the setting to 19(29)-0-04.
- The setting CANNOT be configured if there are alerts or errors present.
- If booster fans are used, you can ONLY configure setting 19(29)-0-03.
- Settings 19(29)-0-04 and 19(29)-0-05 can be configured for multiple units with 1 controller.

13.4 About the controller

13.4.1 BRC1E53 controller



NOTICE

This controller is NOT allowed in combination with EKVDX indoor units.

Please read the manual supplied with the controller (BRC1E53) for more detailed instructions.

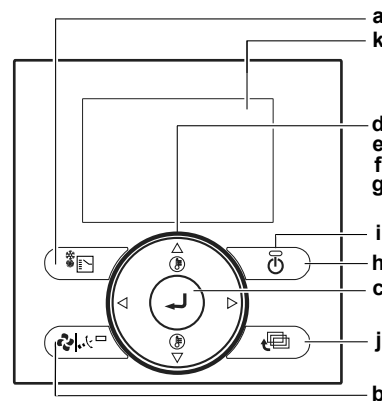

- a Operation Mode Selector button
- b Fan Speed/Airflow Direction button
- c Menu/Enter button
- d Up button
- e Down button
- f Right button
- g Left button
- h ON/OFF button
- i Operation lamp
- j Cancel button
- k LCD (with backlight)

To change the ventilation rate

- Press the Menu/Enter button to display the main menu.
- Press the Up/Down buttons to select Ventilation and press the Menu/Enter button.

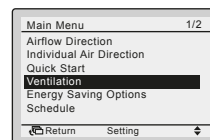

- Press the Up/Down buttons to select Ventilation Rate and press the Menu/Enter button.

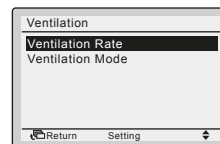

- Press the Up/Down buttons to change the setting to Low or High and press the Menu/Enter button to confirm.

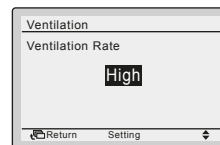

To select ventilation mode

Ventilation mode is used when cooling or heating is NOT necessary, so ONLY the heat reclaim ventilation units are operating.

- Press the Operation Mode Selector button several times until the ventilation mode is selected.

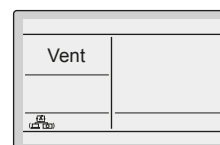

To change the ventilation mode

- Press the Menu/Enter button to display the main menu.

13 Configuration

2 Press the Up/Down buttons to select Ventilation and press the Menu/Enter button.

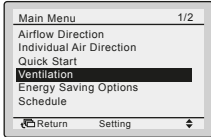

3 Press the Up/Down buttons to select Ventilation Mode and press the Menu/Enter button.

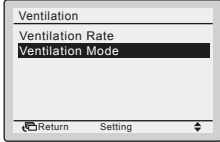

4 Press the Up/Down buttons to select the required ventilation mode. For more information about ventilation modes, see Ventilation modes in the installer and user reference guide.

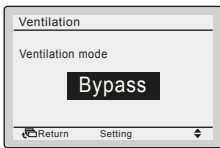

Ventilation modes

You can change the ventilation mode in the main menu.

Mode	Description
Auto mode	Using information from the air conditioner (cooling, heating, fan, and set temperature) and heat reclaim ventilation unit (indoor and outdoor temperatures), this mode automatically switches between Heat Reclaim Ventilation mode and Bypass mode.
Heat Reclaim Ventilation mode (Energy Reclaim Ventilation)	Outdoor air is supplied to the room after passing through a heat exchange element, where heat is exchanged with the room air.
Bypass mode	The outdoor air bypasses the heat exchange element. This means that outdoor air is supplied to the room without heat exchange with the room air.

Time to clean filter indication

When the filter pressure drop becomes too large, the following message or icon is displayed at the bottom of the basic screen: Time to clean filter or . Clean the filters. For more information, see "5 Maintenance and service" ▶ 5].

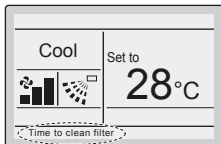

To remove the Time to clean filter indication

- 1 Press the Menu/Enter button.
- 2 Press the Up/Down buttons to select Reset Filter Indicator.
- 3 Press the Menu/Enter button.

Result: You return to the basic screen. The Time to clean filter indication is no longer displayed.

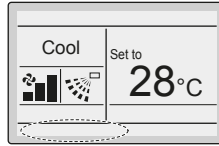
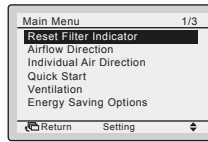

About error indications

If an error occurs, there is an error icon in the basic screen and the operation lamp blinks. If a warning occurs, ONLY the error icon blinks and the operation lamp does NOT. Press the Menu/Enter button to display the error code or warning and contact information.

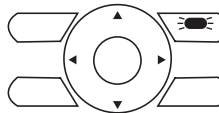
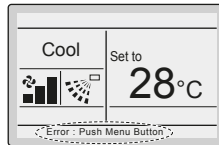

The error code blinks and the contact address and model name appear as shown below. In this case, notify your dealer about the error code.

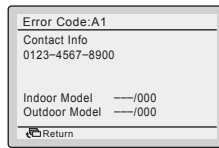

13.4.2 BRC301B61 controller









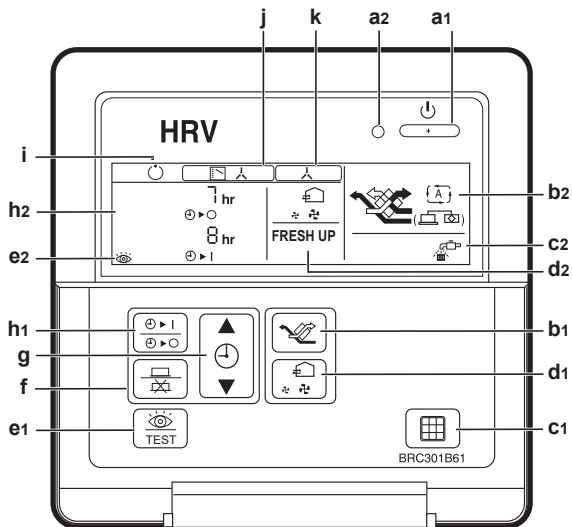























NOTICE

This controller is NOT allowed in combination with EKVDX indoor units.



For non-independent systems, starting, stopping and setting a timer is NOT possible with this controller (BRC301B61). In such cases, use the air conditioner controller (BRC1E53) or the central controller.



Item	Description							
a	On/OFF							
	<p>a1 Operation/Stop button Press this button once and the unit starts to operate. Press this button again and the unit stops.</p> <p>a2 Operation lamp This red pilot lamp lights up while the unit is in operation.</p>							
b	Ventilation mode							
	b1 Ventilation mode changeover button							
	b2 Ventilation mode changeover display							
	<table border="1"> <tr> <td></td> <td>Automatic mode The unit's temperature sensor automatically changes the operation mode of the unit to bypass mode or Heat Reclaim Ventilation mode.</td> </tr> <tr> <td></td> <td>Heat Reclaim Ventilation mode The outdoor air passes through the heat exchange element to effect Heat Reclaim Ventilation.</td> </tr> <tr> <td></td> <td>Bypass mode The outdoor air does NOT pass through the heat exchange element, but bypasses it to deliver cooler air.</td> </tr> </table>		Automatic mode The unit's temperature sensor automatically changes the operation mode of the unit to bypass mode or Heat Reclaim Ventilation mode.		Heat Reclaim Ventilation mode The outdoor air passes through the heat exchange element to effect Heat Reclaim Ventilation.		Bypass mode The outdoor air does NOT pass through the heat exchange element, but bypasses it to deliver cooler air.	
	Automatic mode The unit's temperature sensor automatically changes the operation mode of the unit to bypass mode or Heat Reclaim Ventilation mode.							
	Heat Reclaim Ventilation mode The outdoor air passes through the heat exchange element to effect Heat Reclaim Ventilation.							
	Bypass mode The outdoor air does NOT pass through the heat exchange element, but bypasses it to deliver cooler air.							
c	Air filter cleaning							
	<p>c1 Filter signal reset button</p> <p>c2  Indication of air filter cleaning. When you see this symbol, clean the air filter.</p>							
d	Air flow rate							
	d1 Air flow rate changeover button							
	d2 Air flow rate changeover display							
	 Low							
	 High							
	No FRESH UP (fresh-up) indication: The volume of outdoor air supplied into the room and that of the room air exhausted outdoors is equal.							
	<table border="1"> <tr> <td></td> <td>Low fresh-up</td> </tr> <tr> <td>FRESH UP</td> <td></td> </tr> <tr> <td></td> <td>High fresh-up</td> </tr> <tr> <td>FRESH UP</td> <td></td> </tr> </table> <p>If the fresh-up setting is set to "Fresh-up air supply", the volume of outdoor air supplied into the room is larger than that of room air exhausted outdoors. This prevents odours and moisture from kitchens and toilets from flowing into the room. This is the factory setting.</p> <p>If the fresh-up setting is set to "Fresh-up air exhaust", the volume of room air exhausted outdoors is larger than that of outdoor air supplied into the room. This prevents hospital odours and airborne micro-organisms from flowing out of the room into the corridors. To change the fresh-up settings, see "13.2 Field settings" [p 18].</p>		Low fresh-up	FRESH UP			High fresh-up	FRESH UP
	Low fresh-up							
FRESH UP								
	High fresh-up							
FRESH UP								
e	Inspection							
	e1 Inspection button Use this button ONLY when servicing the unit.							
	e2 Inspection indication							
f	Programming							
	<table border="1"> <tr> <td></td> <td>Programming button</td> </tr> <tr> <td></td> <td></td> </tr> </table>		Programming button					
	Programming button							
								

Item	Description
g	Time adjustment
	 Time adjustment button
h	Schedule timer
	h1  Schedule timer button  This button enables or disables the schedule timer.
	h2 Schedule timer display
i	Indication of operation standby
	 This icon indicates that the unit is precooling/preheating. The unit's start-up is delayed until precooling/preheating is finished. Precooling/preheating means that the heat reclaim ventilation units are NOT started while linked air conditioners are starting up, for example, before office hours. During this period, the cooling or heating load is reduced to bring the room temperature to the set temperature in a short time.
j	Indication of operation control method
	 Only applies to systems where the operation of heat reclaim ventilation units is linked to the air conditioners. While this indication is displayed, you CANNOT turn the heat reclaim ventilation units on or off with the controller of the heat reclaim ventilation units.
k	Indication of central control
	 Only applies to systems where a controller for air conditioners or devices for central control are connected to the heat reclaim ventilation units. While this indication is displayed, you may NOT be able to turn the heat reclaim ventilation units on or off, or use the timer function with the controller of the heat reclaim ventilation unit.

To set the timer

- 1 Press the schedule timer button .
- 2 Press the time adjustment button  to set the time.
- 3 Press the programming button  to save the setting.

13.4.3 BRC1H controller



INFORMATION

Please refer to the Installer and user reference guide of the BRC1H remote controller.

13.4.4 BRC1K controller



INFORMATION

Please refer to the installer and user reference guide of the BRC1K remote controller.

14 Commissioning

14.1 Checklist before commissioning

- 1 After the installation of the unit, check the items listed below.

15 Troubleshooting

- 2 Close the unit.
- 3 Power up the unit.

Checklist

<input type="checkbox"/>	You have read the complete installation and operation instructions described in the installer and user reference guide .
<input type="checkbox"/>	Installation Check that the unit is properly installed, to avoid abnormal noises and vibrations when starting up the unit.
<input type="checkbox"/>	Power supply voltage Check the power supply voltage on the local supply panel. The voltage MUST correspond to the voltage on the nameplate of the unit.
<input type="checkbox"/>	Earth wiring Be sure that the earth wires have been connected properly and that the earth terminals are tightened.
<input type="checkbox"/>	Insulation test of the main power circuit Using a megatester for 500 V, check that the insulation resistance of 2 MΩ or more is attained by applying a voltage of 500 V DC between power terminals and earth. NEVER use the megatester for the interconnection wiring.
<input type="checkbox"/>	Internal wiring Visually check the switch box and the inside of the unit for loose connections or damaged electrical components.
<input type="checkbox"/>	Air inlet/outlet Check that the air inlet and outlet of the unit is NOT obstructed by paper sheets, cardboard, or any other material.
<input type="checkbox"/>	Installation date and field setting Be sure to keep a record of the installation date on the sticker on the rear of the front panel according to EN60335-2-40 and keep record of the contents of the field setting(s).
<input type="checkbox"/>	Fuses, circuit breakers, or protection devices Check that the fuses, circuit breakers, or the locally installed protection devices are of the size and type specified in the chapter " 12 Electrical installation " [▶ 11]. Be sure that no fuse or protection device is bypassed.
<input type="checkbox"/>	Field wiring Check that the field wiring has been carried out according to the instructions described in the chapter " 12 Electrical installation " [▶ 11], according to the wiring diagrams and according to the applicable national wiring regulation.
<input type="checkbox"/>	Installation date and field setting Be sure to keep a record of the installation date on the sticker on the rear of the front panel according to EN60335-2-80 and keep record of the contents of the field setting(s).
<input type="checkbox"/>	EKVDX In case an EKVDX is installed, also see chapter Commissioning in the EKVDX installation and operation manual.

14.2 Checklist during commissioning

<input type="checkbox"/>	To perform a test run .
--------------------------	--------------------------------

14.2.1 About the system test run

After completing the installation of the system, turn on the power of the heat reclaim ventilation units. Refer to the manual of the controller of each unit (controller for air conditioner, central controller, etc.) to conduct a trial operation.

15 Troubleshooting

15.1 Solving problems based on error codes

In case a malfunction code is shown on the display, consult the dealer where the unit was purchased.

15.1.1 Error codes: Overview

Code ^(a)	Description
<i>R1</i>	EEPROM failure
<i>R5</i>	Locked rotor
<i>R5-22</i>	Unstable fan rpm: failure of filter contamination check or failure of function 19(29)-0-04/-05
<i>R5-28</i>	VAM air flow rate dropped below legal threshold limit (for R32 application) ^(b)
<i>R5-29</i>	VAM air flow rate approaches legal threshold limit (for R32 application) ^(b)
<i>R5-30</i>	VAM warning for air flow rate drop (for R32 application) ^(b)
<i>R8</i>	Power supply malfunction
<i>RJ</i>	Capacity setting malfunction
<i>C1</i>	Fan communication error
<i>C5</i>	Malfunction of fan motor sensor or fan control driver
<i>CH</i>	CO ₂ sensor warning
<i>U5</i>	Transmission error between unit and controller
<i>U8</i>	Transmission error between master controller and slave controller ^(c)
<i>UR</i>	Wrong controller installed
<i>UC</i>	Repeated central address
<i>UE</i>	Transmission error between unit and central controller
<i>UJ-36</i>	Miscommunication between VAM and EKVDX
<i>ED</i>	External protection device activated
<i>E4-01</i>	Indoor air thermistor (R1T) malfunction
<i>E4-02</i>	Indoor air thermistor (R1T) out of operation range
<i>E5-01</i>	Outdoor air thermistor (R2T) malfunction
<i>E5-02</i>	Outdoor air thermistor (R2T) out of operation range
<i>E5-03</i>	Functions 19(29)-0-04/-05 not possible due to low outdoor temperature
<i>ER</i>	Damper-related malfunction

^(a) In case of a code with a grey background, the VAM still operates. Inspect and repair the unit as soon as possible.

When connected to an EKVDX and the R32 safety system is active, the VAM can stop operating.

^(b) These error codes only apply when the R32 safety system is active. See Installation and operation manual of the EKVDX for more information about recovery of these errors.

^(c) When combined with the EKVDX, no slave controllers are allowed.

16 Disposal



NOTICE

Do NOT try to dismantle the system yourself: dismantling of the system, treatment of the refrigerant, oil and other parts MUST comply with applicable legislation. Units MUST be treated at a specialised treatment facility for reuse, recycling and recovery.

17 Technical data

- A **subset** of the latest technical data is available on the regional Daikin website (publicly accessible).
- The **full set** of the latest technical data is available on the Daikin Business Portal (authentication required).

17.1 Wiring diagram

The wiring diagram can be found on the outside of the service cover.

Legend for wiring diagrams:

A1P	Printed circuit board
A2P	Printed circuit board assy (fan) (VAM350~650)
A2P-A3P	Printed circuit board assy (fan) (VAM800+1000)
A2P~A5P	Printed circuit board assy (fan) (VAM1500+2000)
C7	Capacitor (M1F)
F1U (A1P)	Fuse (250 V, 6.3 A, T)
F2U (A2P)	Fuse (250 V, 5 A, T) (VAM350~650)
F3U	Fuse (250 V, 6.3 A, T) (VAM800~2000)
F4U (A2P)	Fuse (250 V, 6.3 A, T) (VAM350~650)
HAP	Pilot lamp (service monitor - green)
K*R	Magnetic relay
L*R	Reactor
M1D	Motor (damper)
M2D	Motor (damper) (VAM1500+2000)
M1F	Supply air fan
M2F	Exhaust air fan
M3F	Motor (exhaust air fan) (top) (VAM1500+2000)
M4F	Motor (supply air fan) (top) (VAM1500+2000)
PS	Switching power supply
Q1DI	Field earth leak detector (≤300 mA)
R*	Resistance
R1T	Thermistor (indoor air)
R2T	Thermistor (outdoor air)
R3T	Thermistor (PTC)
S1C	Limit switch damper motor
S2C	Limit switch damper motor (VAM1500+2000)
V1R	Diode bridge
X1M (A1P)	Terminal
X2M (A1P)	Terminal (outside input)
X3M	Terminal (power supply)
Z1F	Noise filter
Z*C	Noise filter (ferrite core)

Remote controller

SS1 Selector switch

Connector for option

X14A Connector (CO₂ sensor)
 X24A Connector (outside damper)
 X33A Connector (contact printed circuit board)
 X35A Connector (power supply printed circuit board)

Symbols:

⋮⋮⋮⋮⋮⋮ Field wiring
 □□□□ Terminals
 Connectors
 Protective earth
 Noiseless earth

Colours:

BLK Black
 BLU Blue
 BRN Brown
 GRN Green
 ORG Orange
 RED Red
 WHT White
 YLW Yellow

Translation of text on wiring diagram

English	Translation
Notes	Notes
X35A is connected when optional accessories are being used, see wiring diagram of this accessory	X35A is connected when optional accessories are being used, see wiring diagram of this accessory
An EKVDX unit and its corresponding VAM-J* unit should be connected to a common power supply. Refer to the installation manual of the EKVDX unit for further details.	An EKVDX unit and its corresponding VAM-J* unit should be connected to a common power supply. Refer to the installation manual of the EKVDX unit for further details.
Transmission wiring	Transmission wiring
Ext. output - error state	External output - error state
Ext. output - R32 alarm	External output - R32 alarm
Caution when performing service inside the el. compo. box	Caution when performing service inside the electrical component box.
Caution for ELECTRIC SHOCK	Caution for ELECTRIC SHOCK
Do not open the el. compo. box cover for 10 minutes after the power supply is turned off.	Do not open the electrical component box cover for 10 minutes after the power supply is turned off.
After opening the el. compo. box, measure (on A1P~A5P) the points shown at the right with a tester and confirm that the voltage of the capacitor in the main circuit is less than DC50V.	After opening the electrical component box, measure (on A1P~A5P) the points shown at the right with a tester and confirm that the voltage of the capacitor in the main circuit is less than DC50V.
Measuring points for voltage	Measuring points for voltage
Printed circuit board	Printed circuit board

17 Technical data

17.2 Service space

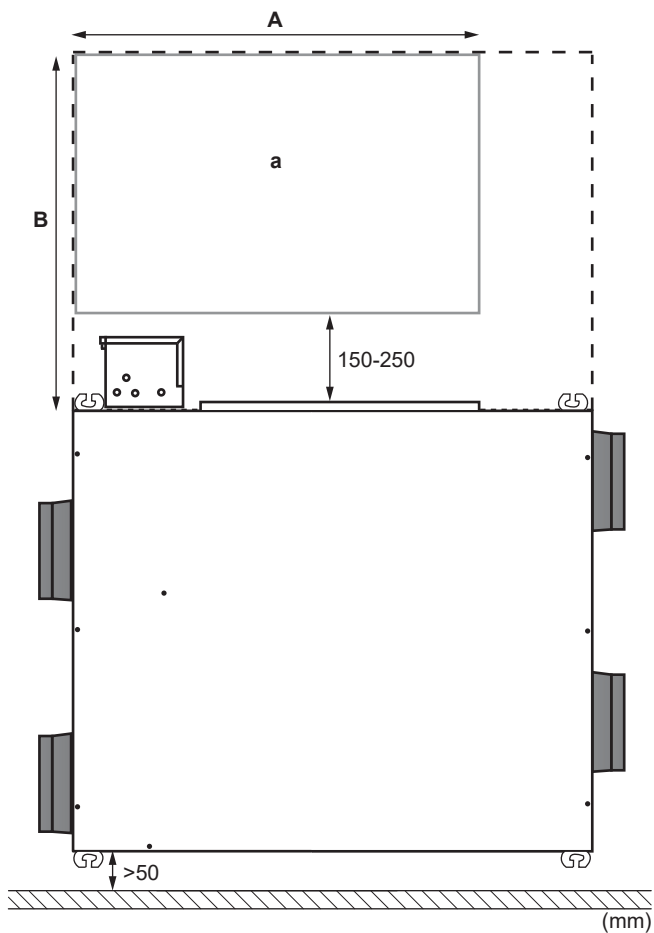

a Service space

Models	A	B
VAM350+500	900 mm	675 mm
VAM650	1100 mm	700 mm
VAM800~2000	1100 mm	850 mm



ERC



4P664011-1 D 0000000Y

Copyright 2021 Daikin

DAIKIN EUROPE N.V.

Zandvoordestraat 300, B-8400 Oostende, Belgium

4P664011-1D 2026.04