

REV	01
Date	July 2018
Supersedes	D-EIMWC01405-18EN

## Installation, maintenance and operating manual D-EIMWC01405-18\_01EN

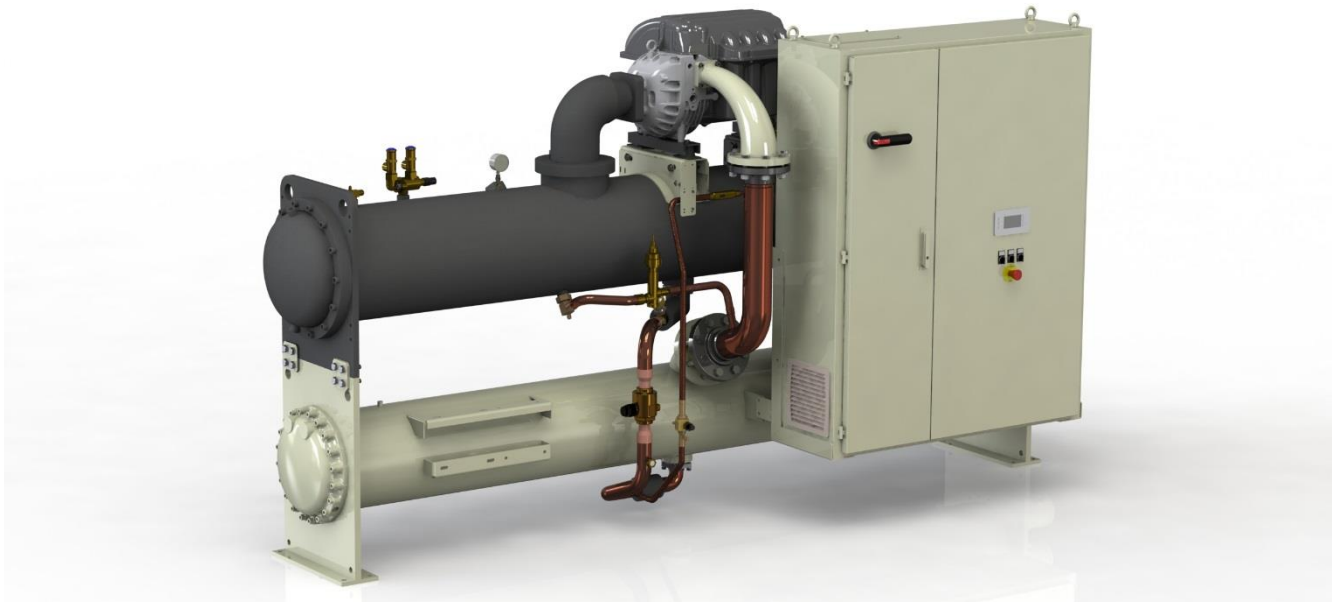
### WATER COOLED OIL FREE CENTRIFUGAL CHILLERS

EWWD – DZ

EWWH - DZ

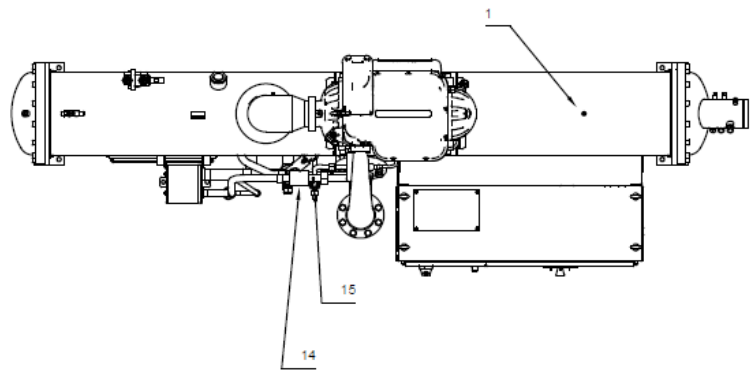
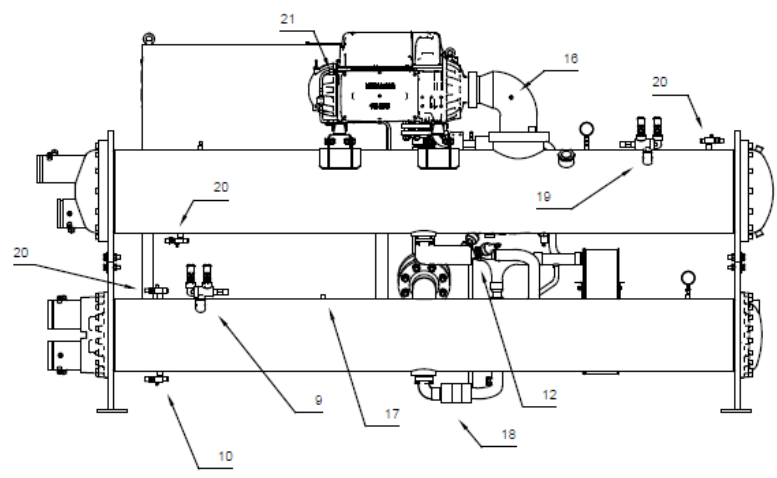
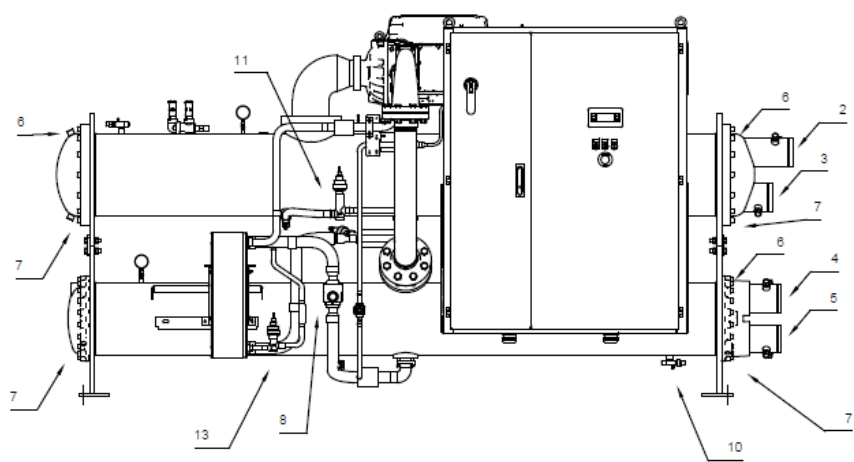
Cooling capacity from 320 to 1480 kW

50Hz - Refrigerant: HFC R134a, R1234ze(E)



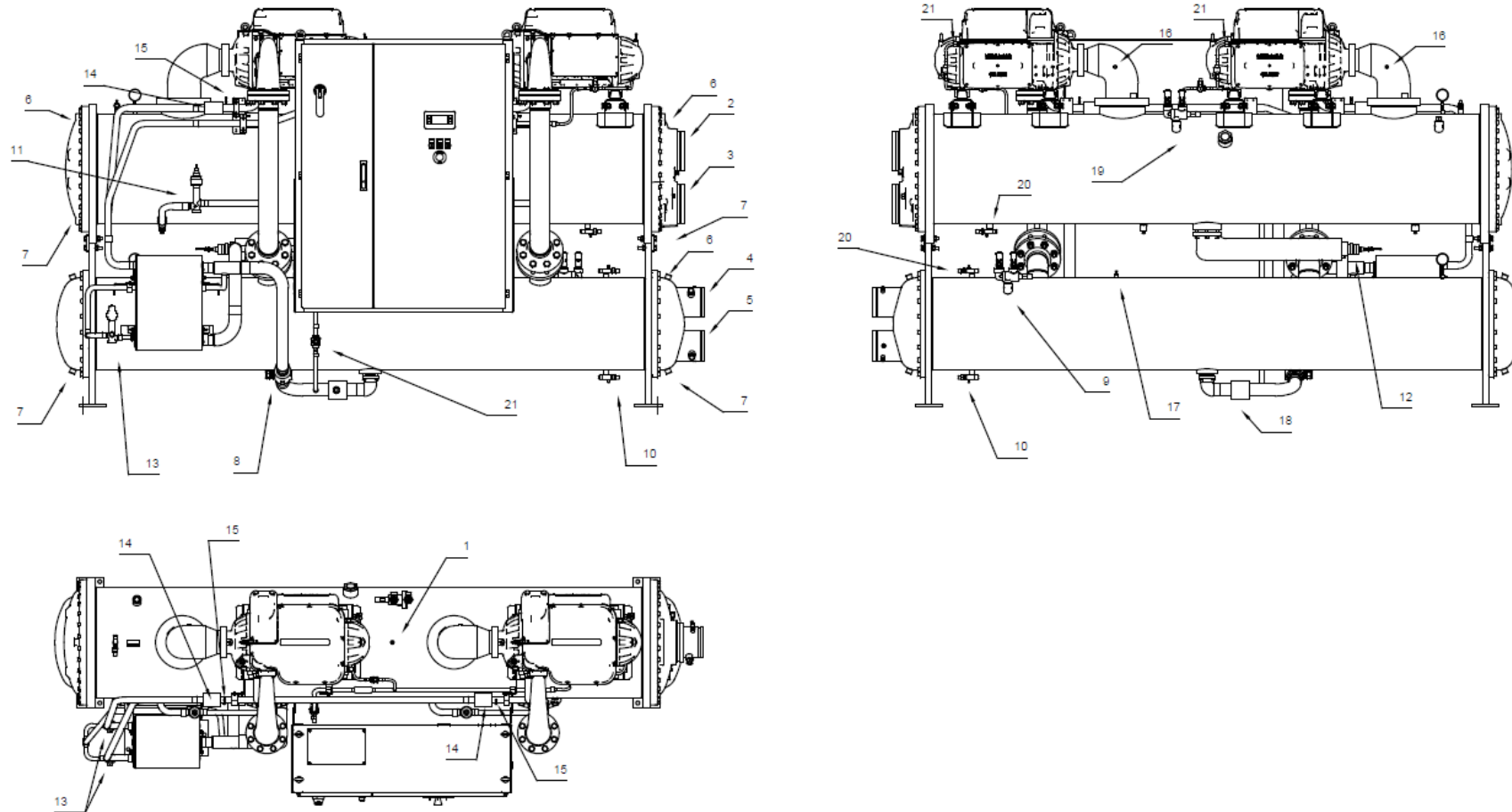
## Contents

<b>1</b>	<b>INTRODUCTION</b> .....	<b>6</b>
1.1	General Description.....	6
1.2	Application.....	6
1.3	Information about R1234ze(E).....	6
1.4	Installation Safety.....	7
1.4.1	Additional guidelines for safe use of R1234ze(E) for equipment located in the open air.....	7
1.4.2	Additional guidelines for safe use of R1234ze(E) for equipment located in a machinery room.....	7
<b>2</b>	<b>INSTALLATION</b> .....	<b>9</b>
2.1	Storage.....	9
2.2	Receiving and handling.....	9
2.3	Lifting instructions.....	10
2.4	Positioning and assembly.....	11
2.5	Shock absorbers.....	11
2.6	Anchoring.....	12
2.7	Water pipes.....	12
2.7.1	Evaporator and condenser water pipes.....	12
2.7.2	Flow Switch.....	12
2.8	Water treatment.....	13
2.9	Temperature limits and water flow.....	14
2.10	Minimum water content in the system.....	14
2.11	Evaporator frost protection.....	15
2.12	Condenser protection and design considerations.....	15
2.12.1	Condensation control with evaporative cooling tower.....	15
2.12.2	Condensation control with well water.....	16
2.13	Chilled water control sensor.....	16
2.14	Safety Valve.....	17
2.15	Open the isolation and/or shut off valves.....	17
2.16	Electrical connections.....	17
2.17	Phase imbalance.....	17
2.18	Control circuit.....	17
<b>3</b>	<b>OPERATION</b> .....	<b>19</b>
3.1	Operator's responsibilities.....	19
3.2	Unit description.....	19
3.3	Safeties for each cooling compressor.....	20
3.4	System safeties.....	20
3.5	Regulation type.....	20
3.6	Compressor Lead-Lag.....	20
3.7	High condensing pressure control.....	20
<b>4</b>	<b>MAINTENANCE</b> .....	<b>21</b>
4.1	Pressure/Temperature Table.....	22
4.2	Routine maintenance.....	23
4.2.1	Check condenser performance.....	23
4.2.2	Electronic expansion valve.....	23
4.2.3	Cooling circuit.....	23
4.2.4	Refrigerant charge.....	26
4.2.5	Check the refrigerant charge.....	26
4.2.6	Electrical Installation.....	26
4.3	Cleaning and Storage.....	27
4.4	Seasonal maintenance.....	27
4.4.1	Seasonal shutdown.....	27
4.4.2	Seasonal start up.....	27
<b>5</b>	<b>SERVICE SCHEDULE</b> .....	<b>27</b>
<b>6</b>	<b>MAINTENANCE SCHEDULE</b> .....	<b>28</b>
<b>7</b>	<b>CHECKS BEFORE FIRST START UP</b> .....	<b>29</b>
<b>8</b>	<b>IMPORTANT INFORMATION ON USED REFRIGERANT</b> .....	<b>30</b>
8.1	Factory and Field charged units instructions.....	30
<b>9</b>	<b>PERIODIC CHECKS AND COMMISSIONING OF PRESSURE VESSELS</b> .....	<b>31</b>
<b>10</b>	<b>DEMOLITION AND DISPOSAL</b> .....	<b>31</b>
<b>11</b>	<b>DURATION</b> .....	<b>31</b>
<b>List of Figures</b>		
	<a href="#">Fig. 1 - Single compressor unit component descriptions</a> .....	3
	<a href="#">Fig. 2 - Dual compressor unit component descriptions</a> .....	4
	<a href="#">Fig. 3-Description of the labels applied to the electric panel</a> .....	5
	<a href="#">Fig. 4 - Unit positioning</a> .....	11
	<a href="#">Fig. 5-Water quality</a> .....	13
	<a href="#">Fig. 6 – Electrical Panel Layout</a> .....	20
	<a href="#">Fig. 7-P&amp;ID Mono and Dual compressor</a> .....	24
	<a href="#">Fig. 8-P&amp;ID Mono and Dual compressor with economizer</a> .....	25

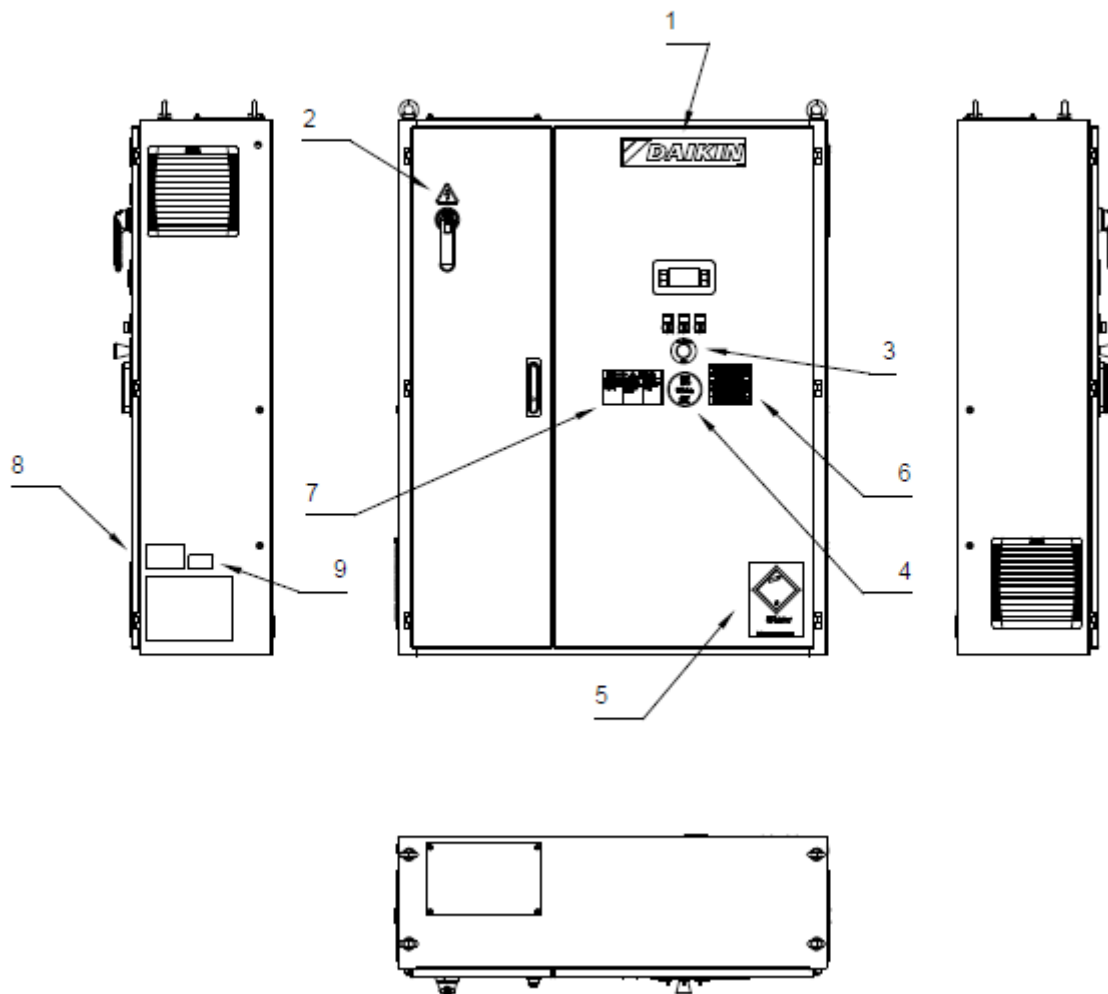


**Fig. 1 - Single compressor unit component descriptions**

<b>1</b>	<b>2</b>	<b>3</b>	<b>4</b>	<b>5</b>	<b>6</b>	<b>7</b>	<b>8</b>	<b>9</b>	<b>10</b>	<b>11</b>
Low pressure transducer	Evaporator outlet water temperature sensor	Evaporator inlet water temperature sensor	Condenser outlet water temperature sensor	Condenser inlet water temperature sensor	Air purge	Water drain	Liquid line shut-off valve	High pressure safety valves	Refrigerant charge service valve	Starter valve
<b>12</b>	<b>13</b>	<b>14</b>	<b>15</b>	<b>16</b>	<b>17</b>	<b>18</b>	<b>19</b>	<b>20</b>	<b>21</b>	
Liquid line expansion valve	Economizer line expansion valve	Economizer line temperature sensor	Economizer line pressure transducer	Suction temperature sensor	High pressure transducer	Liquid temperature sensor	Low Pressure safety valves	Service valve	Inverter cooling line inlet	



**Fig. 2 - Dual compressor unit component descriptions**



**Fig. 3-Description of the labels applied to the electric panel**

**Identification of labels**

1 – Manufacturer's logo	6 – Wire tightness check
2 – Electricity warning	7 – Shock hazard
3 – Emergency button	8 – Lifting instructions
4 – Type of gas	9 – Unit nameplate
5 – UN 2875	

# 1 INTRODUCTION

---

This manual provides information on the functions and standard procedures for all series units and is an important support document for qualified personnel but can never replace them.

All units are supplied complete with wiring diagrams and dimensional drawings that provide information about the size and weight of each model.

In case of discrepancies between the content of the manual and the documentation that came with the unit, always rely to the wiring diagram and dimensional drawings because they are an integral part of this manual.

Read this manual carefully before installing and starting up the unit.

Improper installation can cause: short circuits, leaks, fire or other damages to the equipment or personal injuries.

The unit must be installed by professionals/professional technicians in accordance with current laws of the country of installation.

The unit must also be started by authorized and trained personnel and all activities must be conducted in accordance and in full compliance with local standards and laws.

## **IF THE INSTRUCTIONS IN THIS MANUAL ARE NOT CLEAR, DO NOT INSTALL AND/OR START UP THE UNIT.**

If in doubt, for service and further information, contact the manufacturer's authorized representative.

### **1.1 General Description**

Daikin water chillers, with centrifugal compressors and magnetic bearings, are completely factory assembled and tested before shipment.

The EWWD(H) DZ range consists of models with a single compressor and single cooling circuit (from 320 to 740 kW) and models with two compressors and single cooling circuit (610 to 1480 kW)

The controller is pre-wired, set and tested at the factory.

Only normal connections are required on site such as piping, electrical connections and pump interlocks, making installation easier and more reliable. All operating safety and control systems are factory installed in the control panel. The instructions in this manual apply to all models of this series unless otherwise indicated.

### **1.2 Application**

The EWWD(H) DZ units with centrifugal compressor and adjustment inverters are designed and constructed to cool buildings or industrial processes. Daikin technicians, specifically trained for this purpose, must start the final system for the first time. Failure to follow this starting procedure affects the warranty.

The standard warranty covers parts of this equipment with proven defects in material or workmanship. Materials subject to natural consumption are not, however, covered by the warranty.

The cooling towers used with Daikin units must be selected for a wide scope of application, as described in the "Operating limits" section. From an energy savings point of view it is always preferable to keep the temperature difference between the hot circuit (condenser) and the cold circuit (evaporator) to a minimum. However, it is always necessary to verify that the machine works in the temperature range specified in this manual.

### **1.3 Information about R1234ze(E)**

This product is equipped with refrigerant R1234ze(E) which has minimal impact to the environment, thanks to its low value of Global Warming Potential (GWP). R1234ze(E) refrigerant is classified by European Directive 2014/68/EU as a Group 2 (non-dangerous) substance, as it is nonflammable at standard ambient temperature and non-toxic. Due to this, no special precautions are required for storage, transport and handling.

Daikin Applied Europe S.p.A. products comply with applicable European Directives and refer for unit design to product Standard EN378:2016 and industrial Standard ISO5149. Local authorities approval should be verified referring to European Standard EN378 and/or ISO 5149 (where R1234ze(E) is classified A2L – Mildly flammable gas).

## Physical characteristics of refrigerant R1234ze (E)

Safety Class	A2L
PED Fluid Group	2
Practical limit (kg/m <sup>3</sup> )	0.061
ATEL/ ODL (kg/m <sup>3</sup> )	0.28
LFL (kg/m <sup>3</sup> )@ 60°C	0.303
Vapour density @25°C, 101.3 kPa (kg/m <sup>3</sup> )	4.66
Molecular Mass	114.0
Normal Boiling Point (°C)	-19
GWP (100 yr ITH)	7
GWP (ARS 100 yr ITH)	<1
Auto Ignition Temperature (°C)	368

### 1.4 Installation Safety

All EWWD(H) VZ machines are built in accordance with the main European Directives (Machinery Directive, Low Voltage Directive, Electromagnetic Compatibility Directive for PED pressurized equipment), make sure you also receive the declaration of product conformity with the directives along with the documentation.

Before machine installation and commissioning, the people involved in this activity must have acquired the information necessary to carry out these tasks, applying all the information collected in this book.

Do not allow unauthorized and/or unskilled personnel to access the unit.

Always protect the operating personnel with personal protective equipment appropriate for the tasks to be performed. Commonly used personal equipment include: protective helmet, goggles, gloves, headphones, safety shoes. Additional individual and group protective equipment should be adopted after an adequate analysis of the specific risks in the area of relevance, according to the activities to be performed.

The chiller has to be installed in open air or machinery room (location classification III).

To ensure location classification III a mechanical vent on the secondary circuit(s) has to be installed.

Local building codes and safety standards shall be followed; in absence of local codes and standards refer to EN 378-3:2016 as a guide.

In paragraph "Additional guidelines for safe use of R1234ze(E)" there are provided additional informations that should be added to the requirements of safety standards and building codes.

#### 1.4.1 Additional guidelines for safe use of R1234ze(E) for equipment located in the open air

Refrigerating systems sited in the open air shall be positioned to avoid leaked refrigerant flowing into a building or otherwise endangering people and property.

The refrigerant shall not be able to flow into any ventilation fresh air opening, doorway, trap door or similar opening in the event of a leak. Where a shelter is provided for refrigerating equipment sited in the open air it shall have natural or forced ventilation.

For refrigeration systems installed outside in a location where a release of refrigerant can stagnate e.g. below ground, then the installation shall comply with the requirements for gas detection and ventilation of machinery rooms.

#### 1.4.2 Additional guidelines for safe use of R1234ze(E) for equipment located in a machinery room

When a machinery room is chosen for the location of the refrigerating equipment it shall be located in accordance with local and national regulations. The following requirements (according to EN 378-3:2016) can be used for the assessment.

- A risk analysis based on the safety concept for the refrigerating system (as determined by the manufacturer and including the charge and safety classification of the refrigerant used) shall be conducted to determine whether it is necessary to place the refrigerating system in a separate refrigeration machinery room.
- Machinery rooms should not be used as occupied spaces. The building owner or user shall ensure that access is permitted only by qualified and trained personnel doing the necessary maintenance to the machinery room or general plant.
- Machinery rooms shall not be used for storage with the exception of tools, spare parts and compressor oil for the installed equipment. Any refrigerants, or flammable or toxic materials shall be stored as required by national regulations.
- Open (naked) flames shall not be permitted in machinery rooms, except for welding, brazing or similar activity and then only provided the refrigerant concentration is monitored and adequate ventilation is ensured. Such open flames shall not be left unattended.
- A remote switching (emergency type) for stopping the refrigerating system shall be provided outside the room (near the door). A similar acting switch shall be located at a suitable location inside the room.
- All piping and ducting passing through floors, ceiling and walls of machinery room shall be sealed.
- Hot surfaces shall not exceed a temperature of 80 % of the auto-ignition temperature (in °C) or 100 K less than the auto-ignition temperature of the refrigerant, whichever is higher.
-

Refrigerant	Auto ignition temperature	Maximum surface temperature
R1234ze	368 °C	294 °C

- Machinery rooms shall have doors opening outward and sufficient in number to ensure freedom for persons to escape in an emergency; the doors shall be tight fitting, self-closing and so designed that they can be opened from inside (antipanic system).
- Special machinery rooms where the refrigerant charge is above the practical limit for the volume of the room shall have a door that either opens directly to the outside air or through a dedicated vestibule equipped with self-closing, tight-fitting doors.
- The ventilation of machinery rooms shall be sufficient both for normal operating conditions and emergencies.
- Ventilation for normal operating conditions shall be in accordance with national regulations.
- The emergency mechanical ventilation system shall be activated by a detector(s), located in the machinery room.
  - This ventilation system shall be:
    - independent of any other ventilation system on the site.
    - provided with two independent emergency controls one located outside the machinery room, and the other inside.
  - The emergency exhaust ventilation fan shall:
    - Be either in the air flow with the motor outside the airflow, or rated for hazardous areas (according to the assessment).
    - Be located to avoid pressurization of the exhaust ductwork in the machinery room.
    - not cause sparks to occur if it contacts the duct material.
  - Airflow of the emergency mechanical ventilation shall be at least

$$V = 0,014 \times m^{2/3}$$

where

V is the air flow rate in m<sup>3</sup>/s;

m is the mass of refrigerant charge, in kg, in the refrigerating system with the largest charge, any part of which is located in the machinery room;

0,014 is a conversion factor.

- Mechanical ventilation shall be operated continuously or shall be switched on by the detector.
- Detector shall automatically activate an alarm, start mechanical ventilation and stop the system when it triggers.
- The location of detectors shall be chosen in relation to the refrigerant and they shall be located where the refrigerant from the leak will concentrate.
- The positioning of the detector shall be done with due consideration of local airflow patterns, accounting for location sources of ventilation and louvers. Consideration shall also be given to the possibility of mechanical damage or contamination.
- At least one detector shall be installed in each machinery room or the occupied space being considered and/or at the lowest underground room for refrigerants heavier than air and at the highest point for refrigerants lighter than air.
- Detectors shall be continuously monitored for functioning. In the case of a detector failure, the emergency sequence should be activated as if refrigerant had been detected.
- The pre-set value for the refrigerant detector at 30 °C or 0 °C, whichever is more critical, shall be set to 25 % of the LFL. The detector shall continue to activate at higher concentrations.

Refrigerant	LFL	Pre-set alarm	
R1234ze	0,303 kg/m <sup>3</sup>	0,07575 kg/m <sup>3</sup>	16500 ppm

- All electrical equipment (not only the refrigerating system) shall be selected to be suitable for use in the zones identified in the risk assessment. Electrical equipment shall be deemed to comply with the requirements if the electrical supply is isolated when the refrigerant concentration reaches 25 % of the lower flammable limit or less.
- Machinery rooms or special machinery rooms shall be **clearly marked** as such on the entrances to the room, together with warning notices indicating that unauthorized persons shall not enter and that smoking, naked light or flames are prohibited. The notices shall also state that, in the event of an emergency, only authorized persons conversant with emergency procedures shall decide whether to enter the machinery room. Additionally, warning notices shall be displayed prohibiting unauthorized operation of the system
- The owner / operator shall keep an updated logbook of the refrigerating system.



**The optional leak detector supplied by DAE with the chiller should be used exclusively to check refrigerant leakage from the chiller itself**

## 2 INSTALLATION

---

### 2.1 Storage

Should it be necessary to store the unit prior to installation, it is necessary to observe some precautions.

- Do not remove the protective plastic
- Do not leave the unit exposed to the elements
- Do not expose the unit to direct sunlight
- Do not use the machine near a heat source and/or open flame
- Keep in places where room temperature is between + 5° C to 55° C (room temperature over the maximum limit may trigger the safety valve resulting in loss of refrigerant).

### 2.2 Receiving and handling

Inspect the unit immediately after delivery. In particular, make sure the machine is intact in all its parts and that there are no deformations due to collisions. Should damages be found upon receipt, immediately file a written complaint with the carrier.

Machine returns are Ex factory Daikin Applied Europe S.p.A.

Daikin Applied Europe S.p.A. cannot be held liable for any equipment damages incurred during transportation to the place of destination.

The isolation of the evaporator corners, where the lifting holes are located, are shipped separately and must be assembled on site after the unit has been permanently installed. Even the anti-vibration supports (optional) are shipped separately. Make sure these items, if required, are delivered with the unit.

Use extreme caution when handling the unit to prevent damage to the control panel and the refrigerant pipes.

The unit must be lifted by inserting a hook in each of the four corners, where the lifting holes are located (see lifting instructions). Distancer bars must be used along the line connecting the lifting holes to prevent damages to the electrical panel and the compressor terminal box (see figure). Do not use any other point to lift the machine.

During the lifting phase, check that the lifting cords and/or chains do not touch the electrical panel and/or piping.

If, to move the machine, slides or moving skates are used, just push the base of the machine without touching the pipes, compressors and/or electric panel.

Be careful not to hit, during handling, pipes, cables and installed accessories.

All the necessary devices guaranteeing personal safety must be provided during machine handling.



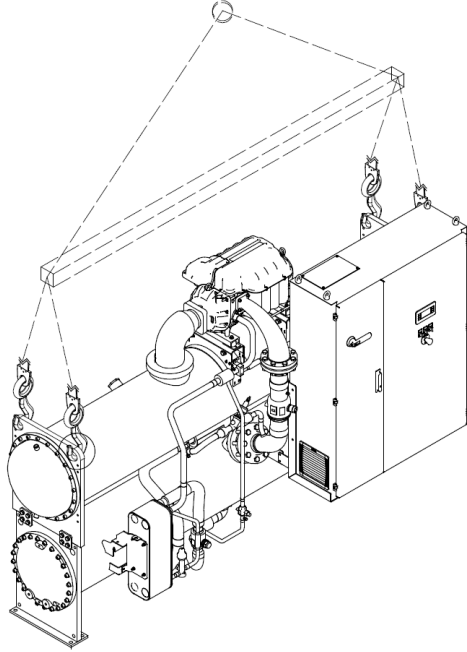
**Refer to the dimensional drawing for hydraulic and electrical unit connections.**

**The overall machine dimensions, as well as the weights described in this manual, are purely indicative.**

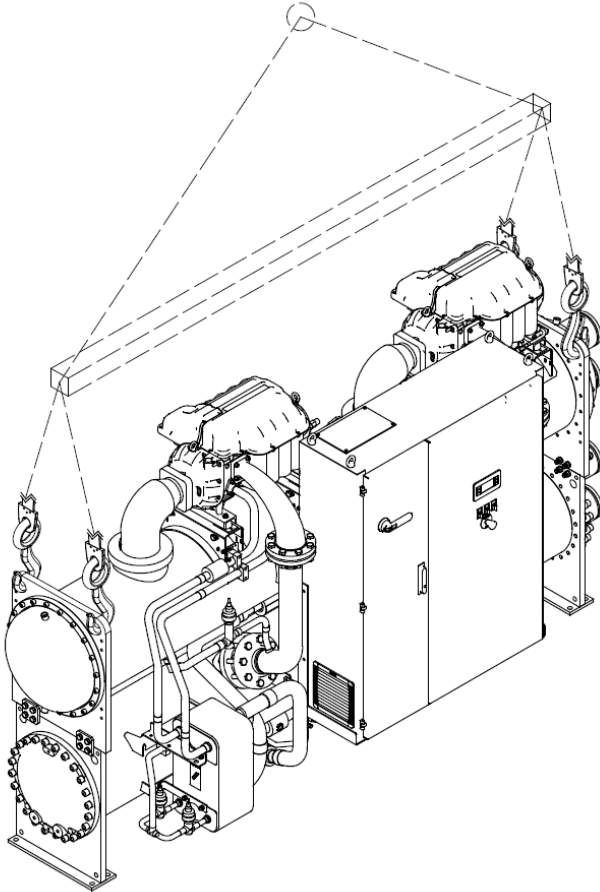
**The contract dimensional drawing and relevant wiring diagram are provided to the customer when ordering.**

---

**2.3 Lifting instructions**



**Single compressor unit**



**Dual compressor unit**

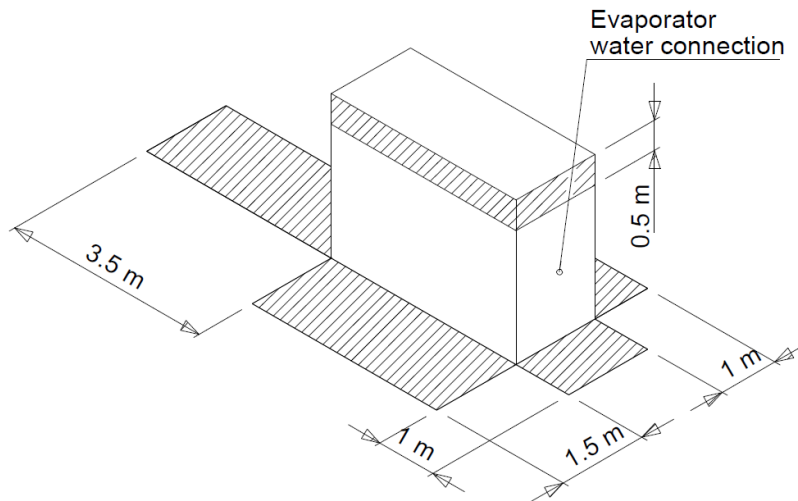
**Fig. 1 – Lifting instructions**

### Lifting instructions:

- 1) The equipment, slings, lifting accessories and handling procedures must meet local regulations and current standards.
- 2) To lift the machine, use only the holes on the heat exchangers.
- 3) Any lifting points should be used during handling.
- 4) Use lifting hooks with closing device exclusively. Hooks must be safely secured before handling.
- 5) The ropes and hooks used must have capacity suited to the load. Check the nameplate on the unit that indicates the machine weight.
- 6) The installer must correctly select and use lifting equipment. We recommend using cables with minimum vertical capacity equal to total machine weight.
- 7) The machine must be lifted slowly and well leveled. If necessary, adjust lifting equipment to guarantee levelling.

### 2.4 Positioning and assembly

The unit must be mounted on a level cement or steel base, suitable to support the overall weight of the complete machine in operation, and must be positioned so as to provide space for maintenance, to allow the cleaning and/or the removal of the evaporator and the condenser pipes. Refer to the figure below for the areas of respect. The condenser and evaporator pipes are expanded inside the tube sheet to allow replacement, if necessary.



**Fig. 4 - Unit positioning**

The machine position should be designed to ensure access to all the safety and control devices. Never cover the safety devices (safety valves, pressure switches), which, due to their importance, are subject to periodic checks. The safety valves outlet must be connected before operations. For safety valve outlet pipe dimensions, we recommend applying harmonized standards and EN13136.

These units include the installation of two safety valves for each exchanger, installed on an exchange tap, which always maintains an active valve. Thus, both safety valves on each exchanger must be connected outside the engine room. These pipes must be installed so that, in case the valve opens, the discharged refrigerant flow not invest people and/or things, or can enter the building through windows and/or other openings.

The engine room must be adequately ventilated to prevent refrigerant accumulation inside that can deprive air of the right oxygen content and thus cause asphyxiation. In this regard, we recommend the application of harmonized standard EN378-3 (Safety and Environmental Requirements - Installation and protection of persons) or equivalent.



***The air contaminated by a high percentage of refrigerant (see refrigerant safety sheet), can cause asphyxiation, loss of mobility and consciousness if inhaled. Avoid eye and skin contact.***

### 2.5 Shock absorbers

The anti-vibration rubber pads (optional), shipped separately, should be placed under the corners of the unit (except for special specifications). These provide a minimum insulation. Pads are recommended on all installations where the transmission of vibrations can be considerable. Also install the anti-vibration joints on water pipes to reduce the stress on pipes, vibrations and noise.



---

***The units are shipped with refrigerant valves closed to isolate such fluids during shipment. The valves must remain closed until such time as an authorized Daikin technician, after inspecting the machine and checked its installation, commissions the machine.***

---

## 2.6 Anchoring

After positioning, the machine must be firmly anchored to the ground or foreseen metal structure to support the machine. In this regard, 22 mm diameter holes are included on the machine base to ensure the anchoring.

## 2.7 Water pipes

### 2.7.1 Evaporator and condenser water pipes

The condensers and evaporators are provided with grooved sleeves for Victaulic connections or optionally with flanged connections. The installer must provide the mechanical coupling with the connections appropriately sized to the system.

Some pressure couplings are included on both the inlet and outlet of the exchangers heads. These couplings control water load loss.

Make sure that the water inlet and outlet connections agree with the dimensional drawing and the indications found on the connections. Incorrect water pipe installation could create machine malfunctions and/or reduce performance.

#### NOTE

When using a hydraulic connection shared with the heating system, make sure the temperature of the water flowing into the evaporator does not exceed the maximum allowed value. This phenomenon might cause the safety valve to open and thus the refrigerant to discharge into the atmosphere.

The pipes, before being attached to the machine, must be supported to reduce the weight and the stress on connections. In addition, the pipes must be adequately insulated. A water filter that can be inspected must also be installed on both inputs (evaporator and condenser). Install shutoff valves on both heat exchangers with suitable dimensions to permit draining and inspection without having to completely drain the system.



---

***To prevent damage to exchanger pipes, install a mechanical filter that can be inspected on each input, able to filter solid objects greater than 1.2 mm in size***

---

### 2.7.2 Flow Switch

A flow switch must be installed on the evaporator inlet pipe to ensure the correct water flow rate, before the unit is started. Furthermore, this device shuts off the unit when water flow is interrupted, protecting the machine from the evaporator freezing.



---

***The flow switch must not be used as a machine control system***

---

The absence of the flow switch on the evaporator water connection, voids the warranty for frost damage.



---

***The evaporator and condenser are not self-draining; both must be purged***

---

Thermometers and pressure gages must be installed on the water pipes near the heat exchangers connections. Furthermore, vent valves must also be installed at the highest points on the pipe.

If necessary, the evaporator and condenser water box can be reversed. If this operation is completed, control sensors have to be repositioned and gasket replaced.

If water pump noise could be excessive, we recommend using rubber insulating joints at both pump inlet and outlet. In most cases it is not necessary to install anti-vibration joints on condenser pipe inlet and outlet but, where the noise and vibration are critical (for example where a buried pipe passes through a wall in an inhabited area), it may be necessary.

If a cooling tower is used, a balancing valve must be installed. A temperature control system is required if the water tower is very cold. The controller installed on the machine manages tower fan on/off or continuously manages a control valve or fan speed controller by means of a 0-10 V DC analog signal. We recommend that you carry out the connection, allowing fan management by the machine controller (see wiring diagram for connection).

## 2.8 Water treatment

Before commissioning the machine, clean the water circuits. Make sure that the tower purge and emptying system is operational. Atmospheric air contains many contaminants so you need a good water treatment.

The use of untreated water can result in: corrosion, erosion, mud, fouling and formation of algae. Daikin Applied Europe is not liable for equipment damage or malfunction due to a lack of a water treatment or water not properly treated.



**Use industrial glycol only.  
Do not use automotive antifreeze.  
Automotive antifreeze contains inhibitors which cause a plating on copper pipes.  
Used glycol handling and disposal must be in accordance with current regulations**

Items (1) (5)	Cooling Water				Cooled Water		Heated water (2)		Tendency if out of criteria
	Circulating System		Once Flow Flowing water	Circulating water (4)		Circulating water [60°C ~ 80°C]	High temperature Supply water (4)		
	Circulating water	Supply water (4)		Circulating water [Below 20°C]	Supply water (4)		Low temperature Circulating water [20°C ~ 60°C]	Supply water (4)	
pH	6.5 ~ 8.2	6.0 ~ 8.0	6.0 ~ 8.0	6.0 ~ 8.0	6.0 ~ 8.0	7.0 ~ 8.0	7.0 ~ 8.0	7.0 ~ 8.0	Corrosion + Scale
Electrical conductivity	[mS/m] at 25°C	Below 80	Below 40	Below 40	Below 30	Below 30	Below 30	Below 30	Corrosion + Scale
	[µS/cm] at 25°C	(Below 800)	(Below 400)	(Below 400)	(Below 300)	(Below 300)	(Below 300)	(Below 300)	Corrosion + Scale
Chloride ion	[mgCl <sup>-</sup> /l]	Below 200	Below 50	Below 50	Below 50	Below 50	Below 50	Below 30	Corrosion
Sulfate ion	[mgSO <sub>4</sub> <sup>2-</sup> /l]	Below 200	Below 50	Below 50	Below 50	Below 50	Below 50	Below 30	Corrosion
M-alkalinity (pH4.8)	[mgCaCO <sub>3</sub> /l]	Below 100	Below 50	Below 50	Below 50	Below 50	Below 50	Below 50	Scale
Total hardness	[mgCaCO <sub>3</sub> /l]	Below 200	Below 70	Below 70	Below 70	Below 70	Below 70	Below 70	Scale
Calcium hardness	[mgCaCO <sub>3</sub> /l]	Below 150	Below 50	Below 50	Below 50	Below 50	Below 50	Below 50	Scale
Silica ion	[mgSiO <sub>2</sub> /l]	Below 50	Below 30	Below 30	Below 30	Below 30	Below 30	Below 30	Scale
Iron	[mgFe/l]	Below 1.0	Below 0.3	Below 1.0	Below 1.0	Below 1.0	Below 1.0	Below 0.3	Corrosion + Scale
Copper	[mgCu/l]	Below 0.3	Below 0.1	Below 1.0	Below 1.0	Below 1.0	Below 1.0	Below 0.1	Corrosion
Sulfite ion	[mgS <sup>2-</sup> /l]	Not detectable	Not detectable	Not detectable	Not detectable	Not detectable	Not detectable	Not detectable	Corrosion
Ammonium ion	[mgNH <sub>4</sub> <sup>+</sup> /l]	Below 1.0	Below 0.1	Below 1.0	Below 1.0	Below 0.3	Below 0.1	Below 0.1	Corrosion
Remaining chloride	[mgCl/l]	Below 0.3	Below 0.3	Below 0.3	Below 0.3	Below 0.25	Below 0.1	Below 0.3	Corrosion
Free carbide	[mgCO <sub>2</sub> /l]	Below 4.0	Below 4.0	Below 4.0	Below 4.0	Below 0.4	Below 0.4	Below 4.0	Corrosion
Stability index	6.0 ~ 7.0	---	---	---	---	---	---	---	Corrosion + Scale

1 Names, definitions and units are according to JIS K 0101. Units and figures between brackets are old units published as reference only.

2 In case of using heated water (more than 40°C), corrosion is generally noticeable.

Especially when the iron materials is in direct contact with water without any protection shields, it is desirable to give the valid measure for corrosion. E.g. chemical measure

3 In the cooling water using hermetic cooling tower, close circuit water is according to heated water standard, and scattered water is according to cooling water standard.

4 Supply water is considered drink water, industrial water and ground water except for genuine water, neutral water and soft water.

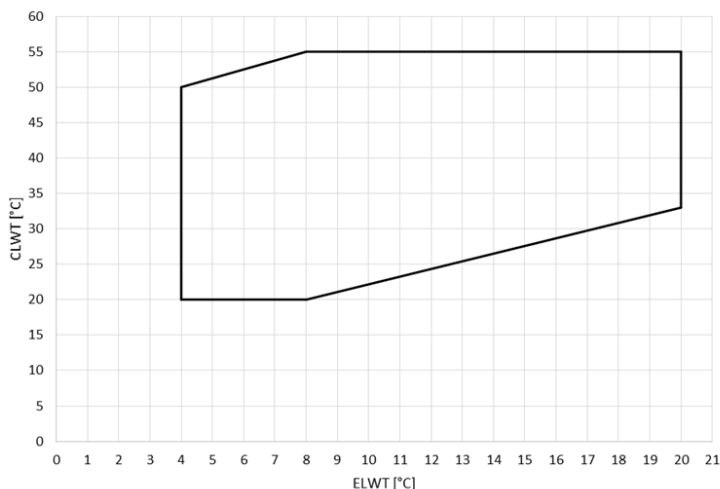
5 The above mentioned items are representable items in corrosion and scale cases.

Fig. 5-Water quality

## 2.9 Temperature limits and water flow

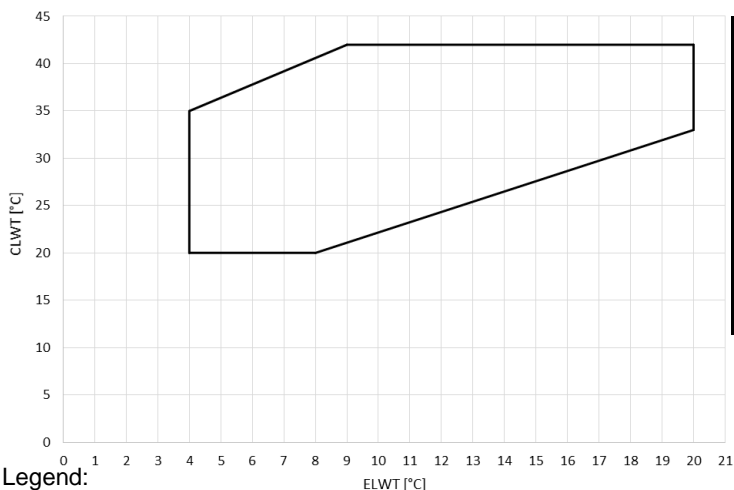
EWWD(H) DZ units are designed to operate with an evaporator outlet water temperature between 4°C and +20°C and a condenser outlet water temperature between 20°C and 50°C. However, the minimum temperature difference between the evaporator outlet water temperature and the condenser inlet water temperature must not be less than 15° C. Always check the exact operating point with the selection software. Some simultaneous operating conditions (high evaporator inlet water temperature and high condenser inlet water temperature) may be inhibited. The maximum permissible water temperature in the evaporator with the machine off is 50° C. Higher temperatures could cause the safety valves on the evaporator sleeve to open. Water flow rate in the condenser and evaporator under the rated value indicated in the unit selection point can cause freezing problems, scale and poor control. Water flow rate in the condenser and evaporator higher than the rated value indicated in the unit selection point results in an unacceptable pressure drop and excessive erosion of the pipes and vibrations that can cause breakage.

### EWWD(H)-DZ DRY COOLER VERSION



Dry cooler version Model	
EWWD320DZXSA1	EWWH230DZXSA1
EWWD340DZXEA1	EWWH245DZXEA1
EWWD440DZXSA1	EWWH320DZXSA1
EWWD470DZXEA1	EWWH345DZXEA1
EWWD610DZXSA2	EWWH430DZXSA2
EWWD640DZXSA2	EWWH455DZXSA2
EWWD670DZXEA2	EWWH470DZXEA2
EWWD680DZXEA2	EWWH490DZXEA2
EWWD880DZXSA2	EWWH640DZXSA2
EWWD950DZXEA2	EWWH685DZXEA2

### EWWD(H)-DZ COOLING TOWER VERSION



Cooling tower version Model	
EWWD530DZXSA1	EWWH380DZXSA1
EWWD570DZXEA1	EWWH405DZXEA1
EWWD700DZXSA1	EWWH460DZXSA1
EWWD740DZXEA1	EWWH480DZXEA1
EWWD10DZXSA2	EWWH755DZXSA2
EWWD11DZXEA2	EWWH810DZXEA2
EWWD14DZXSA2	EWWH920DZXSA2
EWWD15DZXEA2	EWWH955DZXEA2

Legend:

ELWT Evaporator outlet water temperature

CLWT Condenser outlet water temperature

## 2.10 Minimum water content in the system

For correct machine operations and the necessary operating stability, it is important to ensure a minimum water content in the system. An accumulation tank with suitable volume may be required for this purpose.

The minimum water content must be calculated by considering the following specifications:

Application	Mono Compressor	Dual Compressor
Conditioning	3.3 lt/kW	2.5 lt/kW
Process	6.6 lt/kW	5.0 lt/kW
Variable capacity	6.6 lt/kW	5.0 lt/kW

Calculation example for EWWD(H)950DZXE units

Cooling capacity at 100% = 946 kW

Minimum system volume for conditioning:  $946 \times 3.3 = 3122$  lt

Minimum system volume for processing:  $946 \times 6.6 = 6243$  lt

Minimum system volume at variable capacity:  $946 \times 6.6 = 6243$  lt

---

**Note:** The calculation formula described above, takes into account several factors such as the compressor stop time and the admissible temperature difference between the last compressor stop and start. In this regard, the minimum water content calculated refers to the machine operations in a normal climate control system. If the machine is used for process activities or if higher operating stability is required, we recommend doubling the calculated water content. In very simple systems, an inertial accumulation tanks may be necessary on the hydraulic circuit to reach the required minimum water volume. Adding this component must guarantee correct water mixing and, therefore, we recommend you select a tank that includes an internal diaphragm for this purpose.

---

**Note:** If the evaporator water circuit operates in a variable flow system, the minimum water flow rate must not be less than 50% of the water flow at nominal conditions, and the variation should not be greater than 10% of the nominal flow per minute.

---

## 2.11 Evaporator frost protection

1. If the machine is idle during the winter, drain and rinse the evaporator and chilled water pipes with glycol. Drain and air vent connections are included on the evaporator for this purpose.
2. We recommend adding glycol in proper proportion to the condenser cooling system. The freezing temperature, of the water-glycol solution, must be at least 6° C lower than the expected minimum ambient temperature.
3. Insulate pipes especially chilled water ones to avoid condensation.



**Damage caused by freezing is not covered by warranty, therefore, Daikin Applied Europe SpA cannot be held liable.**

---

## 2.12 Condenser protection and design considerations

If lake, river or ground water is used as the cooling fluid and the water valves have a leak, the condenser and liquid refrigerant line temperatures could drop under room temperature when the machine is off. This problem occurs when cold water circulates through the condenser and the unit remains off waiting load. If this happens:

1. Turn off the condenser water pump when the compressor is off.
2. Check that the liquid line expansion valve is working properly.

### 2.12.1 Condensation control with evaporative cooling tower

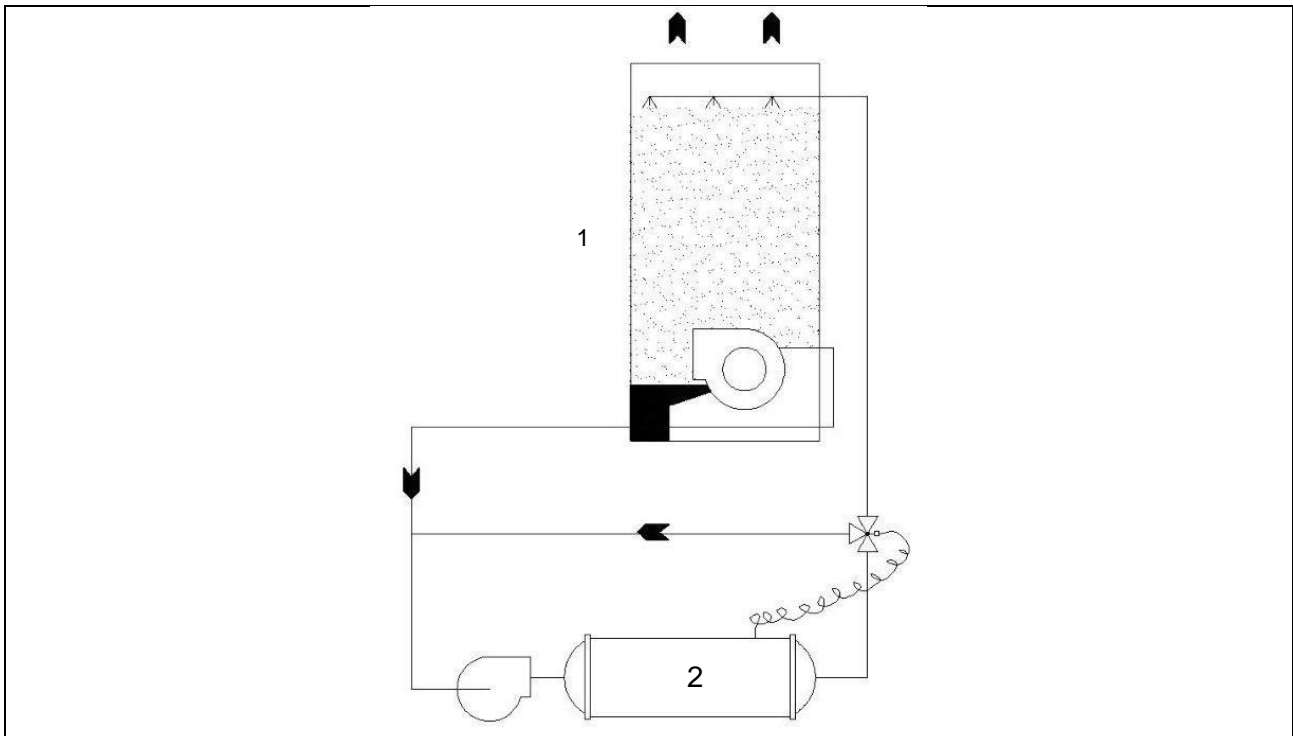
The minimum condenser inlet water temperature should not be less than 20° C at full water tower flow rate.

If the water temperature must be lower, even the water flow must be reduced proportionately.

To modulate the water flow to the condenser, install a three-way by-pass valve. The figure shows how the three-way valve is applied to cool the condenser. The three-way valve can be activated by a pressure actuator which guarantees proper condensing pressure in the case where the water temperature entering the condenser is less than 20° C. A three-way servo-controlled valve or inverter driven circulation pump could be used instead of a valve with pressure actuator. Both of these devices could be controlled by a 0-10 Vdc analogue signal emitted by the machine electronic controller according to the condenser inlet water temperature.

**Fig. 3 – Condenser control scheme with cooling tower**

1	Cooling tower
---	---------------



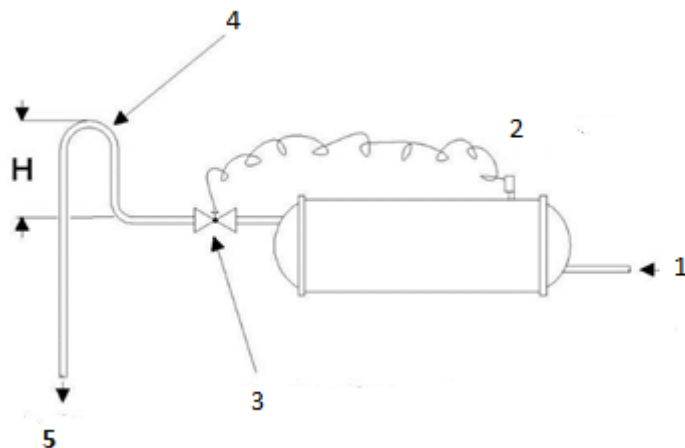
2	Condenser
---	-----------

### 2.12.2 Condensation control with well water

If ground water is used to cool the condenser, install a normally regulating control valve, direct drive, at condenser outlet. This regulating valve must ensure an adequate condensing pressure in the case where the water temperature entering the condenser is less than 20° C.

A service valve with pressure outlet is provided on the condenser shell for this purpose.

The valve must modulate its opening according to condensing pressure. When the machine shuts down, the valve will close preventing the condenser from emptying.



**Fig. 4 – Condensation control scheme with well water**

1	From the main condenser pump
2	Service valve
3	Direct acting water regulating valve
4	Configuration required when the regulating valve is not used
5	At Drain

### 2.13 Chilled water control sensor

The water cooled EWW(D) VZ unit is equipped with a microprocessor. Be careful when working around the unit to avoid damaging cables and sensors. Check cables before starting the unit. Prevent rubbing of the cables on the frame or other components. Make sure the cables are securely locked. If the temperature sensor is removed for maintenance, do not eliminate the conductive paste in the well and replace the sensor correctly. After replacing the sensor, tighten the lock nut to prevent accidental slipping.

## 2.14 Safety Valve

Each exchanger (evaporator and condenser) is provided with a safety valve installed on a changeover valve that allows maintenance and periodic checks, without losing a significant amount of refrigerant. Do not leave the changeover device in the intermediate position.



**To prevent damages due to inhalation and direct contact with refrigerant gas, the safety valve outlets must be connected with a conveyor pipe before operations. These pipes must be installed so that, in case the valve opens, the discharged refrigerant flow not invest people and/or things, or can enter the building through windows and/or other openings. The installer is responsible for connecting the safety valve to the purge pipe and pipe dimensioning. In this regard, refer to the harmonized standard EN13136 to dimension the drain pipes to be connected to the safety valves**

## 2.15 Open the isolation and/or shut off valves

Before powering the machine and thus starting the compressors, open all valves that were closed at the factory for shipping.

The valves to be opened are:

- Valve (optional) installed on the discharge line.
- Liquid line valve installed under the condenser.
- Valve on the liquid injection line (inverter cooling).
- Valve (optional) installed on the suction line.

## 2.16 Electrical connections

The unit must be connected with copper wire of adequate section, based on the maximum absorbed current indicated on the unit label and in accordance with applicable electrical regulations.

Daikin Applied Europe S.p.A. cannot be held liable for improper electrical connections.



**The connections to the terminals must be made with copper terminals and cables.  
The electrical connection must be made by qualified personnel.  
There is a risk of electric shock**

The electrical panel must be connected keeping the correct phase sequence.

## 2.17 Phase imbalance

In a three-phase system, excessive imbalance between the phases is the cause of motor overheating. The maximum allowed voltage imbalance is 2%, calculated as follows:

$$\text{Imbalance \%} = \frac{(Vx - Vm) * 100}{Vm}$$

Vx = phase with greatest imbalance

Vm = average of the voltages

I.e. the three phases measure 383, 386 and 392 volts respectively, the average is:

$$\frac{383+386+392}{3} = 387 \text{ V}$$

The percentage of imbalance is thus:

$$\frac{(392-387) * 100}{387} = 1,29\% \quad \text{less than the maximum admitted (2\%)}$$



**Before any maintenance and/or electrical connection to the compressor inverter, make sure the system is turned off and the unit main switch open.  
After turning off the main switch, wait at least 20 minutes for the inverter condensers to completely discharge. Do not perform any maintenance and/or electrical connection in this period of time.**

## 2.18 Control circuit

Each EWWD(H) VZ unit is factory tested. Both the control and power circuits undergo a careful functional test before the machine is shipped.

The EWWD(H) VZ unit control circuit is powered at 230 Vac.

The controller ON/OFF switch (Q0) must be rotated to the OFF position whenever machine operations are not required.

Water flow switch interlock terminals are included in the controller. See the wiring diagram for the correct connections on the field.

The purpose of the water flow switch interlock is to prevent the compressor from running for enough time to let the two evaporator and condenser water pumps to operate and ensure the correct water flow. The flow switch can be supplied on request from Daikin Applied Europe and in any case must be compulsorily installed on the machine. For better protection against freezing, connecting the evaporator flow switch, connect free contact or pump circuit breaker contact in series.

It is best to leave pump control to the microprocessor for better system management.

If an external system independently manages pump start, follow this logic.

Evaporator water inlet

- turn on the pump 2 minutes before enabling the machine
- turn off the pump 5 minutes after disabling the machine

Condenser water pumps:

- turn the pump on 30 seconds before enabling the machine
- turn the pump off 1 minute after the last compressor is turned off.

## 3 OPERATION

---

### 3.1 Operator's responsibilities

It is important that the operator becomes familiar with the equipment before operating the machine. In addition to reading this manual, the operator should study the operation manual and the wiring diagram supplied with the unit to understand commissioning, operation and the shutdown sequence as well as the shutdown mode and safeties.

During initial machine start-up, the Daikin technician is available to answer any questions and instruct on proper operating procedures.

The operator should keep an operating data log for each specific machine. Furthermore, an additional maintenance log should be kept for periodic maintenance and service.

This Daikin unit represents a substantial investment and deserves the attention and care to keep this equipment in good working order. If the operator observes abnormal or unusual operating conditions, calling Daikin technical service is recommended.

In any case, it is essential to follow the instructions below during operation and maintenance:

- Do not allow unauthorized and/or unskilled personnel to access the unit.
- It is forbidden to access the electrical components without having opened the unit main switch and switched off the power supply.
- It is forbidden to access the electrical components without using an insulating platform. Do not access electrical components if water and/or moisture are present.
- Ensure that all operations on the refrigerant circuit and on components under pressure are exclusively carried out by qualified personnel.
- Compressors should only be replaced by qualified personnel.
- Sharp edges can cause injuries. Avoid direct contact.
- Do not introduce solid objects into the water pipes while the unit is connected to the system.
- A mechanical filter must be fitted to the water pipe connected to the heat exchanger inlet.
- It is absolutely forbidden to remove any protection system covering moving parts.

In case of sudden stop of the unit, follow the instructions on the Control Panel Operating Manual which is part of the on-board documentation delivered to the end user.

It is strongly recommended to perform installation and maintenance with other people.

In case of accidental injury or unease, it is necessary to:

- Keep calm.
- Press the alarm button if present in the installation site.
- Immediately contact any emergency personnel in the building or the call the Emergency Services.
- Wait until emergency personnel arrive and do not leave the injured person alone.

### 3.2 Unit description

The machine is made up of a latest generation, high efficiency **flooded shell and tube evaporator**, with the refrigerant outside the tubes and the water to be cooled flowing inside the tube..

A shell and tube condenser where the refrigerant condenses outside the tubes while the cooling water flows inside of the high-efficiency tubes.

An economizer is included in the DZ series XE version. **The economizer is a plate exchanger** and uses an electronic expansion valve for each compressor. The algorithm, in the controller, monitors various thermodynamic cycle parameters to control these valves.

The **compressor is a centrifugal type with magnetic bearings** and thus does not require lubrication oil. A part of the refrigerant in the liquid line is used to cool the inverter, thus permitting optimal compressor operations in the foreseen conditions. Refrigerant flow is controlled by the compressor that continuously monitors inverter temperature.

The compressor, controlled by inverters, changes its cooling load according to the rotational speed decided by the controller. In this way the machine perfectly adapts to system operating conditions to maximize performance.

The cooling circuit also installs an electronic overflow valve that, in addition to managing the level of refrigerant in the heat exchangers, guarantees the correct operation of the compressor, keeping it within the foreseen limits.

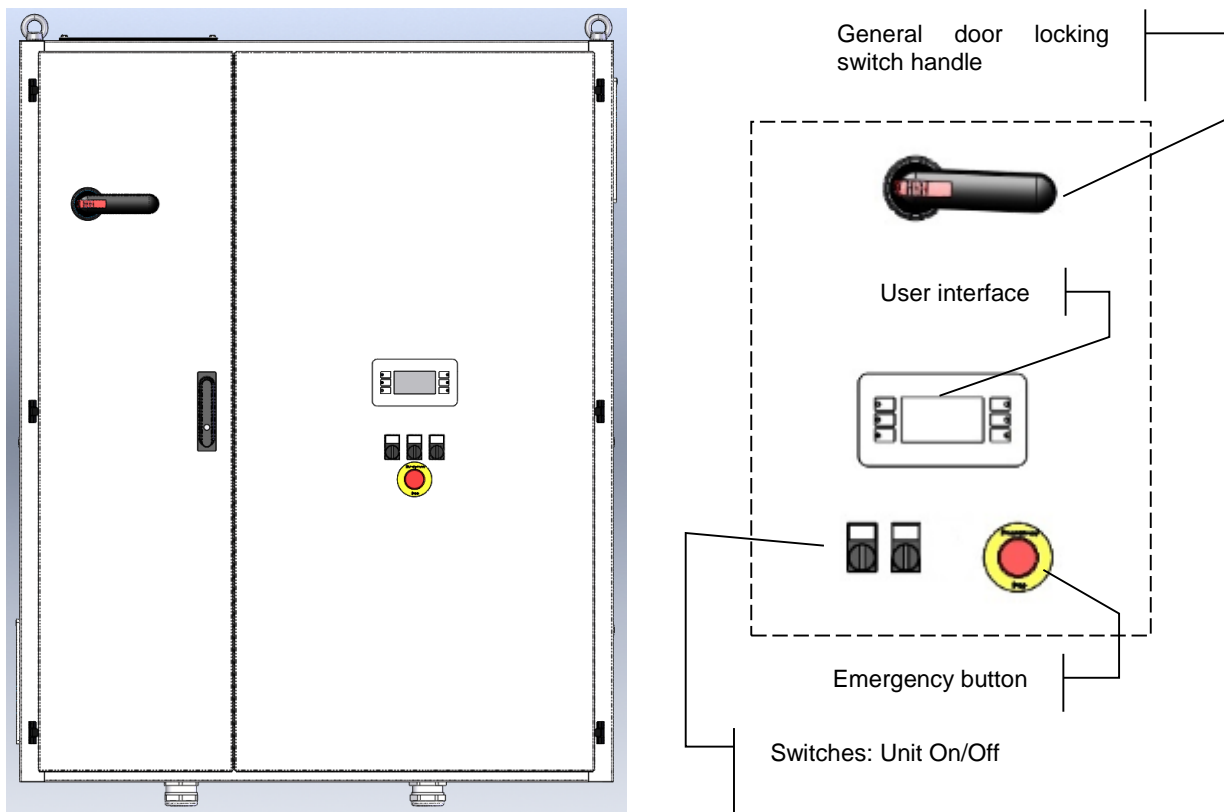
All the described components are managed by an innovative microprocessor control system that, by monitoring all the machine operating parameters, optimizes operations. A diagnostic system helps the operator in identifying alarm and fault causes.



***Before starting the compressors ensure that all valves are open and the closing caps are repositioned and tightened.***

---

The unit controller is a microprocessor control panel designed to perform compressor start up step by step, monitor and adjust compressor capacity, protecting it, and perform the shutdown sequence in the absence of load or at a set time. The control panel provides a wide range of data control and registration capacity options. It is important to have good familiarity with the control system for optimal machine operations. Please note that all units are also provided with the Control Manual.



**Fig. 6 – Electrical Panel Layout**

### 3.3 Safeties for each cooling compressor

- Motor cooling
- High compressor delivery temperature
- Compressor suction temperature
- Failed start
- Low pressure
- High pressure
- Inverter alarm

### 3.4 System safeties

- Antifreeze
- Correct phase sequence and phase failure
- Evaporator flow switch

### 3.5 Regulation type

PID regulation (Proportional - Integrative - Derivative) on the evaporator outlet sensor for perfect water temperature regulation ( $\Delta T = \pm 0.3^\circ \text{C}$ ).

### 3.6 Compressor Lead-Lag

The water-cooled Daikin EWWD(H)\_DZ units alternate the compressor start sequence (EWWD(H)\_DZ dual compressor) to balance the number of starts and operating hours. Compressors are automatically alternated by the controller.

If the unit is in automatic mode, the compressor with the lowest number of starts is started first. If both compressors are in operation and one compressor must be turned off, the one with most hours is switched off

### 3.7 High condensing pressure control

The microprocessor is provided with a transducer to monitor condensing pressure. Although the main purpose of the high pressure transducer is to maintain proper control of the condensing pressure (by controlling the cooling towers if connected), another purpose is to send a signal to the microprocessor which stops the compressor in case the discharge pressure is excessive. If the unit is switched off for high condensing pressure, the microprocessor must be reset manually.

## 4 MAINTENANCE

Personel working on the electrical or the refrigeration components must be authorized, trained and fully qualified.

Maintenance and repair requiring the assistance of other skilled personnel should be carried out under the supervision of the person competent in the use of flammable refrigerants. Any person conducting servicing or maintenance on a system or associated parts of the equipment should be competent according to EN 13313.

**Persons working on refrigerating systems with flammable refrigerants should have competence in safety aspects of flammable refrigerant handling supported by evidence of appropriate training.**

Always protect the operating personnel with personal protective equipment appropriate for the tasks to be performed. Common individual devices are: Helmet, goggles, gloves, caps, safety shoes. Additional individual and group protective equipment should be adopted after an adequate analysis of the specific risks in the area of relevance, according to the activities to be performed.

<p><b>electrical components</b></p>	<p>Never work on any electrical components, until the general supply to the unit has been cut using the disconnect switch(es) in the control box. The frequency variators used are equipped with capacitor batteries with a discharge time of 20 minutes; after disconnecting power wait 20 minutes before opening the control box.</p>
<p><b>refrigerating system</b></p>	<p>The following precautions should be taken before working on the refrigerant circuit:</p> <ul style="list-style-type: none"> <li>— obtain permit for hot work (if required);</li> <li>— ensure that no flammable materials are stored in the work area and that no ignition sources are present anywhere in the work area;</li> <li>— ensure that suitable fire extinguishing equipment is available;</li> <li>— ensure that the work area is <b>properly ventilated</b> before working on the refrigerant circuit or before welding, brazing or soldering work;</li> <li>— ensure that the leak detection equipment being used is non-sparking, adequately sealed or intrinsically safe;</li> <li>— ensure that all maintenance staff have been instructed.</li> </ul> <p>The following procedure should be followed before working on the refrigerant circuit:</p> <p>remove refrigerant (specify the residual pressure);          purge circuit with <b>inert gas</b> (e.g. nitrogen);          evacuate to a pressure of 0,3 (abs.) bar (or 0,03 MPa);          purge again with <b>inert gas</b> (e.g. nitrogen);          open the circuit.</p> <p>The area should be checked with an appropriate refrigerant detector prior to and during any hot work to make the technician aware of a potentially flammable atmosphere.</p> <p>If compressors or compressor oils are to be removed, it should be ensured that it has been evacuated to an acceptable level to ensure that there is no flammable refrigerant remaining within the lubricant.</p> <p><b>Only refrigerant recovery equipment designed for use with flammable refrigerants should be employed.</b></p> <p>If the national rules or regulations permit the refrigerant to be drained, this should be done safely, using a hose, for example, through which the refrigerant is discharged into the outside atmosphere in a safe area. It should be ensured that an inflammable explosive refrigerant concentration cannot occur in the vicinity of an ignition source or penetrate into a building under any circumstance.</p> <p>In the case of refrigerating systems with an indirect system, the heat-transfer fluid should be checked for the possible presence of refrigerant.</p> <p>After any repair work, the safety devices, for example refrigerant detectors and mechanical ventilation systems, should be checked and the results recorded.</p> <p>It should be ensured that any missing or illegible label on components of the refrigerant circuit is replaced.</p> <p>Sources of ignition should not be used when searching for a refrigerant leak.</p>

#### 4.1 Pressure/Temperature Table

HFC-134a Pressure/Temperature Table							
°C	Bar	°C	Bar	°C	Bar	°C	Bar
-14	0,71	12	3,43	38	8,63	64	17,47
-12	0,85	14	3,73	40	9,17	66	18,34
-10	1,01	16	4,04	42	9,72	68	19,24
-8	1,17	18	4,37	44	10,3	70	20,17
-6	1,34	20	4,72	46	10,9	72	21,13
-4	1,53	22	5,08	48	11,53	74	22,13
-2	1,72	24	5,46	50	12,18	76	23,16
0	1,93	26	5,85	52	13,85	78	24,23
2	2,15	28	6,27	54	13,56	80	25,33
4	2,38	30	6,7	56	14,28	82	26,48
6	2,62	32	7,15	58	15,04	84	27,66
8	2,88	34	7,63	60	15,82	86	28,88
10	3,15	36	8,12	62	16,63	88	30,14

HFO-R1234ze(E) Pressure/ Temperature conversion table									
°C	kPa	°C	kPa	°C	kPa	°C	kPa	°C	kPa
-15	20	4	150	23	369	43	731	62	1239
-14	25	5	159	25	399	44	754	63	1271
-13	30	6	169	26	414	45	776	64	1304
-12	36	7	178	27	430	46	800	65	1337
-11	42	8	188	28	445	47	823	66	1370
-10	47	9	198	29	462	48	848	67	1405
-9	53	10	208	30	478	49	872	68	1440
-8	60	11	219	31	496	50	898	69	1475
-7	66	12	230	32	513	51	923	70	1511
-6	73	13	241	33	531	52	949	71	1548
-5	79	14	252	34	549	53	976	72	1585
-4	86	15	264	35	568	54	1003	73	1623
-3	94	16	276	36	587	55	1031	74	1662
-2	101	17	289	37	606	56	1059	75	1701
-1	109	18	301	38	626	57	1088	76	1741
0	117	19	314	39	646	58	1117	77	1782
1	125	20	327	40	667	59	1147	78	1823
2	133	21	341	41	688	60	1177	79	1865
3	141	22	355	42	709	61	1208	80	1908

## **4.2 Routine maintenance**

### **4.2.1 Check condenser performance**

It is important to periodically check the internal cleanliness of the copper tubes, in order to prevent deteriorated performance. This check can be carried out by checking that the difference between the condensation temperature and the condenser outlet water temperature on the microprocessor does not exceed 4° C. If deviations from this value occur, run the specific cleaning procedure.

### **4.2.2 Electronic expansion valve**

EWWD(H)\_DZ units use an a main electronic expansion valve for both single and dual compressor machines. The valves are managed and controlled by the main electronic controller that optimizes the flow of refrigerant gas to the evaporator according to machine operating conditions. The valve control logic prevents, together with compressor load control, machine operations beyond the allowed operation limits. Normally, the only maintenance required for this device is checking valve management via controller.

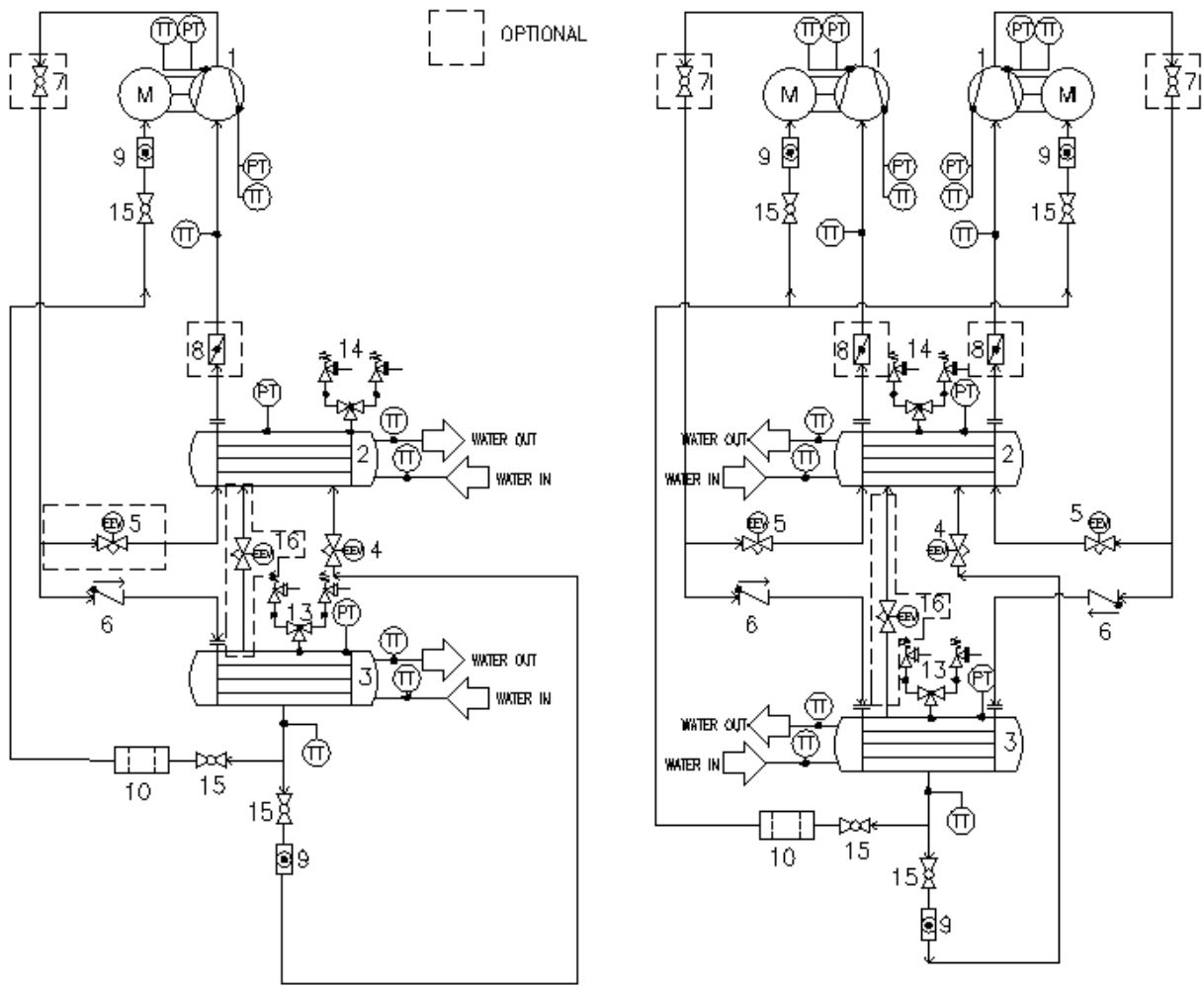
### **4.2.3 Cooling circuit**

Cooling circuit maintenance consists of recording operating conditions and making sure the unit has the correct amount of refrigerant. Record the following for each circuit upon inspection:

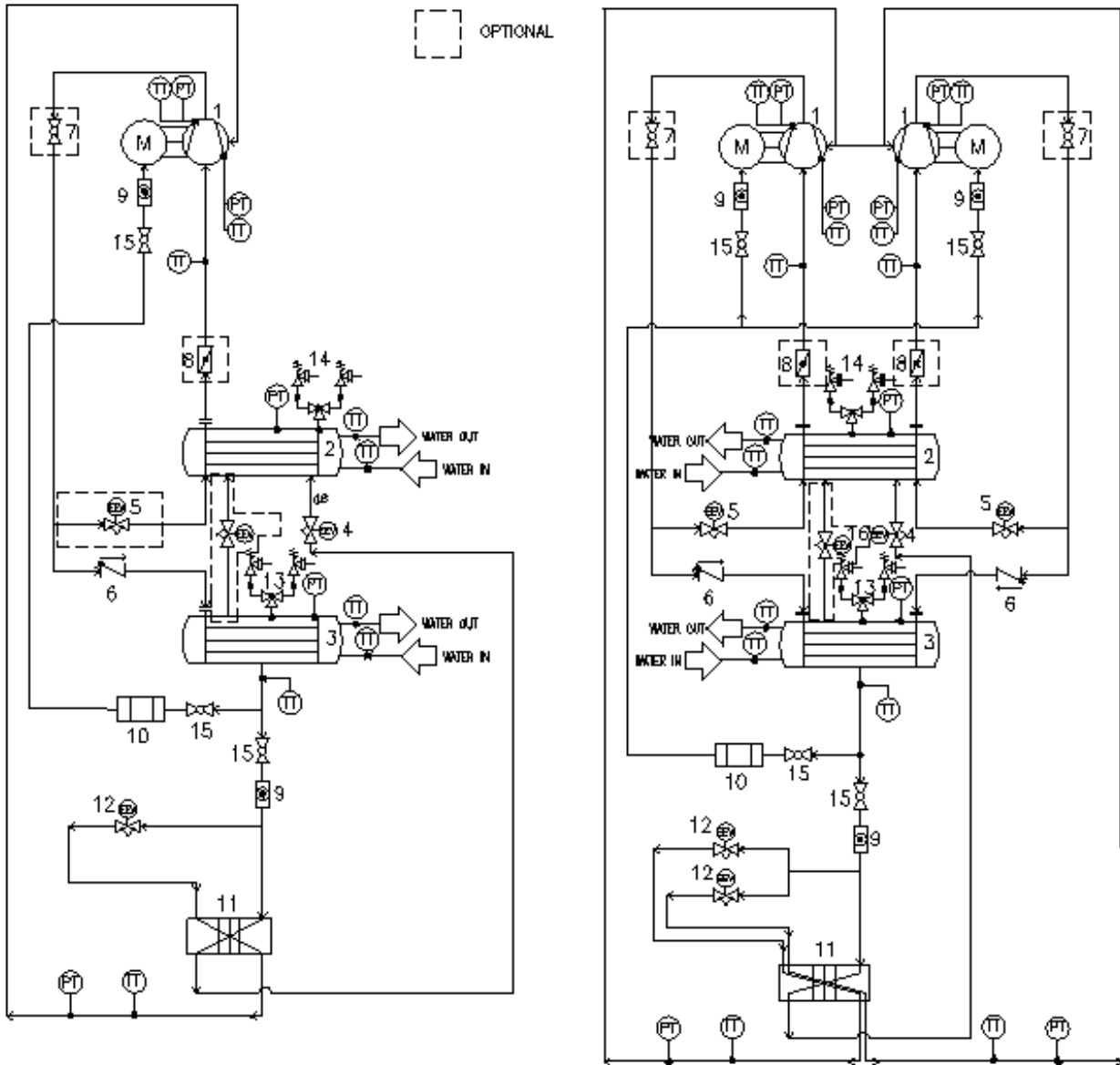
- Discharge and suction pressure
- Discharge and suction temperature
- Liquid temperature
- Evaporator inlet/outlet water temperature
- Condenser inlet/outlet water temperature
- Absorbed current, power voltage and percent compressor load

Significant discharge subcooling and/or superheating value changes, can be a symptom of low refrigerant load.

The correct unit discharge superheating value of the unit at full load must be between 8 and 15° C with R134a fluid, while subcooling must be between 3.5 and 6.0° C (machine at full load).



**Fig. 7-P&ID Mono and Dual compressor**



**Fig. 8-P&ID Mono and Dual compressor with economizer**

Legend	
Item	Description
1	Centrifugal Compressor
2	Flooded shell and tube evaporator
3	Shell and tube condenser
4	Electronic expansion valve
5	Starter valve
6	Check valve
7	Ball valve (optional)
8	Throttle valve (optional)
9	Liquid sight glass
10	Strainer
11	Economizer
12	Economizer electronic expansion valve
13	High pressure safety valve - HP (Pt=18 barg)
14	Low pressure safety valve - LP (Pt=16 barg)
15	Ball valve
16	Electronic expansion valve hot gas by-pass (optional)
PT	Pressure transducer
TT	Temperature sensor

#### 4.2.4 Refrigerant charge

The EWWD(H) DZ units are designed to operate with R134a refrigerant therefore DO NOT USE other refrigerants.



***When you add or remove refrigerant gas, always ensure correct water flow in the evaporator and the condenser to avoid freezing pipes.  
Freeze damage will void the warranty.***

The removal of refrigerant and drainage operations has to be made by qualified technicians with the use of appropriate material for the unit. Improper maintenance can lead to uncontrolled loss of pressure and fluid. Do not discard refrigerant in the environment. Always use an appropriate waste disposal system.

All units are shipped with a full refrigerant charge. If the unit needs to be recharged in the field, follow these recommendations. The optimum charge is one that allows the unit to operate with a correct flow of refrigerant in all conditions.

#### 4.2.5 Check the refrigerant charge

To check whether the unit is operating with the correct refrigerant charge, you should check the following:

1. Bring the machine to maximum load conditions
2. Ensure that the evaporator outlet water temperature is in the range of 6 to 8° C.
3. Verify that the condenser inlet water temperature is between 25 and 32° C.
4. Under the conditions described above, check that:
  - a) Discharge superheating is between 8 and 15°C.
  - b) Subcooling is between 4 and 6° C
  - c) The temperature difference between outlet water and evaporation is comprised between 0.5 and 4° C.
  - d) The temperature difference between condensation and condenser outlet water is between 1 and 3° C.
5. Make sure the indicator on the liquid sight glass is full.

If one of these parameters exceeds the indicated limits, the machine may require additional refrigerant.

---

**Note:** As the unit changes load, the subcooling value changes but will stabilise quickly. The subcooling value slightly changes as the evaporator and condenser outlet water temperature changes.

---

A loss of refrigerant can be so small as to have little effect on the circuit, or may be so obvious as to cause the machine to shutdown triggered by safety protections.

#### 4.2.6 Electrical Installation

The electrical installation involves the application of some general rules as described below:

1. The current absorbed by the compressor must be compared with the nameplate value. Normally, the absorbed current value is less than the nameplate value that corresponds to compressor absorption at full load at maximum operating conditions.
2. At least once every three months all the safety checks should be made to intervene to check its functionality. Each unit, with aging, can change its operating point and this should be monitored to possibly fix or replace it. Pump interlocks and flow switches should be checked to make sure that they interrupt the control circuit when triggered.

### 4.3 Cleaning and Storage

A common cause of the equipment failure and subsequent service call is dirt. This can be prevented with regular maintenance. Actions to be taken on system components must subject to dirt are:

- Clean the electrical panel ventilation and cooling filters, make sure ventilation correctly starts on the electrical panel.
- Remove and clean the filters in the chilled water system, in the cooling water system at each inspection.

### 4.4 Seasonal maintenance

Before you turn off the unit for a long period of time and starting it again, proceed as follows:

#### 4.4.1 Seasonal shutdown

1. Where the unit may be subject to freezing temperatures, the condenser and the cooling water pipes must be disconnected and drained of all water. Blow dry air through the condenser; this operation will help to eliminate all water. Both the condenser that the evaporator is not self-draining. If water remains in the pipes and the heat exchanger, these can be damaged in case of freezing.

**The forced circulation of the antifreeze solution through the water circuit is a sure way to eliminate the risk of freezing.**

2. Care should be taken to prevent the accidental opening of the water circuit shut-off valves.
3. If you are using a cooling tower and if the water pump is exposed to freezing temperatures, remove the pump drain plug to prevent the accumulation of water.
4. Open the compressor switch and remove the fuses. Set the 1/0 manual switch to 0.
5. To avoid corrosion, clean and paint rusted surfaces.
6. Clean and drain the water tower on all units operating with a tower. Make sure tower emptying is effective. Follow a good maintenance program to prevent the formation of limescale deposits both in the tower in the condenser. Take into account that the atmospheric air contains many contaminants that increase the need of proper water purification. The use of untreated water can result in corrosion, erosion, fouling or the formation of algae. We recommend you contact an expert for reliable water purification.
7. Remove the condenser heads at least once a year to inspect the pipes and clean if necessary.



***Daikin Applied Europe Spa cannot be held liable for damage caused by untreated or improperly treated water.***

---

#### 4.4.2 Seasonal start up

Annual start up is a good time to perform the following checks:

1. Check and tighten all electrical connections.
2. The control circuit must be switched off for the entire time.
3. Replace the cooling tower pump drain plug if it was removed during previous season shutdown.
4. Install the main fuses (if removed).
5. Reconnect water lines and refill the circuit. Purge the condenser and check for leaks.

## 5 SERVICE SCHEDULE

---

It is important that all air conditioning systems receive adequate maintenance. The entire system benefits if the system is in good conditions.

The maintenance program must be continuous from first system start: Full inspection must be made after three or four weeks of normal operation and continue regularly.

Daikin Applied Europe offers a variety of maintenance services through its local Daikin service departments and through a worldwide service organization and can adapt their services to the customer's needs.

For more information on service availability, contact your Daikin service department.

## 6 MAINTENANCE SCHEDULE

The following table contains a set of maintenance procedures to be performed and their frequency.

	Monthly	Quarterly	Semi-annually	Annually	As Required By Performance
<b>I. Compressor</b>					
A. Analyse the compressor alarm log		X			
B. Check correct IGV operations		X			
C. Check electrical connection torque				X	
D. Implement humidity prevention measures (condensate)				X <sup>(d)</sup>	
<b>II. Controller</b>					
A. Controller operations					
• Check settings and operation			X		
• Check shutter operating settings			X		
• Check load balancing			X		
B. Protection checks					
• Function test on:					
Alarm outputs		X			
Pump interlocks		X			
High and low pressure intervention		X			
High discharge temperature intervention		X			
<b>III. Condenser</b>					
A. Capacity evaluation <sup>(a)</sup>	O				
B. Water quality analysis		X			
C. Clean condenser tubes					X <sup>(b)</sup>
E. Seasonal Protection (antifreeze)					X
D. Clean the flow switch				X	X
<b>IV. Evaporator</b>					
A. Capacity evaluation <sup>(a)</sup>	O				
B. Water quality analysis		X			
C. Clean evaporator tubes					X <sup>(c)</sup>
E. Seasonal Protection (antifreeze)					X
<b>V. Expansion valves</b>					
A. Function check		X			
<b>VI. Unit</b>					
A. Capacity evaluation	O				
B. Refrigerant leak test					X <sup>(e)</sup>
C. Vibration test		X			
D. General appearance:					
• Paint/corrosion				X <sup>(f)</sup>	
• Heat insulation status				X <sup>(f)</sup>	
<b>VII. Electrical components</b>					
A. Check and adjust line voltage					
B. Inspect components for signs of overheating					
C. Check and tighten electrical components					

Legend: O = Performed by internal staff

X = Performed by qualified technical staff

<sup>(a)</sup> Temperature control at inlet and outlet

<sup>(b)</sup> If approach is > 5°C

<sup>(c)</sup> If approach is > 4°C

<sup>(d)</sup> Refer to the compressor service manual

<sup>(e)</sup> According to F-gas regulations and local standards

<sup>(f)</sup> Increase frequency in aggressive environments

## 7 CHECKS BEFORE FIRST START UP

Job Name: \_\_\_\_\_

Unit model No.(s): \_\_\_\_\_

Daikin unit serial No.: \_\_\_\_\_

**Warning** The unit should never be operated before Daikin Applied authorised start up. Failure to observe this warning could cause serious equipment damages and void the warranty

	Yes	No	N/D
<b>Cooled water circuit</b>			
- Complete piping	<input type="checkbox"/>	<input type="checkbox"/>	<input type="checkbox"/>
- Clean water circuit, full and air drained	<input type="checkbox"/>	<input type="checkbox"/>	<input type="checkbox"/>
- Pumps installed and operating (rotation checked)	<input type="checkbox"/>	<input type="checkbox"/>	<input type="checkbox"/>
- Filters installed and clean	<input type="checkbox"/>	<input type="checkbox"/>	<input type="checkbox"/>
- Control operations (three-way valve, bypass valve, etc.)	<input type="checkbox"/>	<input type="checkbox"/>	<input type="checkbox"/>
- Flow switch installed	<input type="checkbox"/>	<input type="checkbox"/>	<input type="checkbox"/>
- Water circuit operating and flows balanced at required conditions	<input type="checkbox"/>	<input type="checkbox"/>	<input type="checkbox"/>
<b>Condenser water circuit (cooling water units)</b>			
- Clean water circuit, full and air drained	<input type="checkbox"/>	<input type="checkbox"/>	<input type="checkbox"/>
- Pumps installed and operating (rotation checked)	<input type="checkbox"/>	<input type="checkbox"/>	<input type="checkbox"/>
- Filters installed and clean	<input type="checkbox"/>	<input type="checkbox"/>	<input type="checkbox"/>
- Control operations (three-way valve, bypass valve, etc.)	<input type="checkbox"/>	<input type="checkbox"/>	<input type="checkbox"/>
- Water circuit operating and flows balanced at required conditions	<input type="checkbox"/>	<input type="checkbox"/>	<input type="checkbox"/>
<b>Electrical network</b>			
- Power cables connected to the electrical panel	<input type="checkbox"/>	<input type="checkbox"/>	<input type="checkbox"/>
- Power cables corrected connected with U-V-W for L1, L2, & L3 respectively.	<input type="checkbox"/>	<input type="checkbox"/>	<input type="checkbox"/>
- Wired pump starter and interlock	<input type="checkbox"/>	<input type="checkbox"/>	<input type="checkbox"/>
- Complete cooling tower fan electrical connections	<input type="checkbox"/>	<input type="checkbox"/>	<input type="checkbox"/>
- Electrical connections compliant with local electrical standards	<input type="checkbox"/>	<input type="checkbox"/>	<input type="checkbox"/>
<b>Miscellaneous</b>			
- Safety valve pipes complete	<input type="checkbox"/>	<input type="checkbox"/>	<input type="checkbox"/>
- Unit installed according to Daikin specifications	<input type="checkbox"/>	<input type="checkbox"/>	<input type="checkbox"/>
- Well for probes, temperature probes, pressure gauges, etc. installed	<input type="checkbox"/>	<input type="checkbox"/>	<input type="checkbox"/>
- A minimum plant load available for 60% machine load to run checks and make any adjustments.	<input type="checkbox"/>	<input type="checkbox"/>	<input type="checkbox"/>

All installation work must be completed (as required above), the plant inspected and unit ready for operations. If plant conditions do not allow the unit to operate within the limits set in the catalogue, the unit cannot be started. If the above conditions cannot be guaranteed, the customer is liable for the Daikin Applied commissioning approval.

### Site Engineer

Name: \_\_\_\_\_

Date: \_\_\_\_\_

Signature: \_\_\_\_\_

Daikin Applied Europe S.p.A.  
Servicesupport@daikinapplied.eu

**Notes: This list must be completed and sent to the local Daikin Service department at least two weeks before the start.**

## 8 IMPORTANT INFORMATION ON USED REFRIGERANT

This product contains fluorinated greenhouse gases. Do not vent gases into the atmosphere.

**Refrigerant type:** R134a  
**GWP value (Global Warming Potential):** 1430

The amount of refrigerant is indicated on the nameplate with the unit name.

Periodical inspections for refrigerant leaks may be required depending on European or local legislation. Please contact your local dealer for more information.

For more detailed information, contact your local authorized dealer.

### 8.1 Factory and Field charged units instructions

The refrigerant system is charged with greenhouse effect fluorinated gas and the refrigerant charge is printed on the plate, shown below, that is affixed inside the electrical panel.

1 Fill in with indelible ink the refrigerant charge label supplied with the product as following instructions:

- the refrigerant charge for each circuit (1; 2; 3) added during commissioning;
- the total refrigerant charge (1 + 2 + 3)
- **calculate the greenhouse gas emission with the following formula:**

GWP value of the refrigerant x Total refrigerant charge (in kg) / 1000

The diagram shows a rectangular label with the following content and labels:

- a**: Points to the warning icon and text "Contains fluorinated greenhouse gases".
- b**: Points to the circuit number field "1".
- c**: Points to the "Factory charge" column.
- d**: Points to the "Field charge" column.
- e**: Points to the "kg" unit for each circuit calculation.
- f**: Points to the "kg" unit for the total refrigerant charge calculation.
- g**: Points to the "kg" unit for the total refrigerant charge (Factory + Field).
- h**: Points to the "tCO<sub>2</sub>eq" unit for the greenhouse gas emission calculation.
- m**: Points to the refrigerant type "R134a".
- n**: Points to the GWP value "1430".
- p**: Points to the unit serial number field "CH-XXXXXXXX-KKKKXX".

The calculation table on the label is as follows:

1	=	<input type="text"/>	+	<input type="text"/>	kg
2	=	<input type="text"/>	+	<input type="text"/>	kg
3	=	<input type="text"/>	+	<input type="text"/>	kg
-----					
1	+	2	+	3	= <input type="text"/> + <input type="text"/> kg
Total refrigerant charge Factory + Field					<input type="text"/> kg
GWP x kg/1000					<input type="text"/> tCO <sub>2</sub> eq

- a Contains fluorinated greenhouse gases
- b Circuit number
- c Factory charge
- d Field charge
- e Refrigerant charge for each circuit (according to the number of circuits)
- f Total refrigerant charge
- g Total refrigerant charge (Factory + Field)
- h **Greenhouse gas emission** of the total refrigerant charge expressed in equivalent CO<sub>2</sub> tonnes
- m Refrigerant type
- n GWP = Global Warming Potential
- p Unit serial number

#### NOTICE

In Europe, **greenhouse gas emission** of the total refrigerant charge in the system (expressed in equivalent CO<sub>2</sub> tonnes) is used to determine maintenance frequency. Follow the applicable legislation.

Use the GWP value mentioned on the label. This GWP value is based on the 4th IPCC Assessment Report. The GWP value mentioned in the manual might be outdated (i.e. based on the 3rd IPCC Assessment Report)

## 9 PERIODIC CHECKS AND COMMISSIONING OF PRESSURE VESSELS

---

The units described in this manual fall under category IV of the classification determined by the European Directive 2014/68/EU (PED).

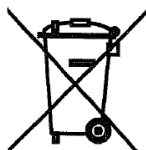
Based on local regulations, a commissioning check and periodic checks may be required. Please verify and contact these organizations to also request authorization to start it up.

## 10 DEMOLITION AND DISPOSAL

---

The unit is made up of metal, plastic and electronic components. All these components must be disposed of in accordance with local laws regarding disposal and, if in scope, with the national laws implementing the Directive 2012/19/EU (RAEE). Batteries and electrical components must be sent to specific waste collection centres.

Prevent refrigerant gases from polluting the environment using suitable pressure vessels and means to transfer the pressurized fluid. This operation must be carried out by personnel trained in refrigeration plants and in accordance with applicable laws of the country of installation.



## 11 DURATION

---

The useful life of this unit is 10 (ten) years.

After this period, the manufacturer recommends the installation is overhauled and, especially, that pressurized cooling circuit integrity is checked as required by the laws in force in some EU countries.

The present publication is drawn up by of information only and does not constitute an offer binding upon Daikin Applied Europe S.p.A.. Daikin Applied Europe S.p.A. has compiled the content to the best of their knowledge. Refer to the data communicated at the time of the order. All the data and specifications contained herein are liable to change without notice. Refer to the data communicated at the time of the order. Daikin Applied Europe S.p.A. cannot be held liable for direct or indirect damage, in the broadest sense of the term, arising from or related to the use and/or interpretation of this publication. All content is copyrighted by Daikin Applied Europe S.p.A.

**DAIKIN APPLIED EUROPE S.p.A.**

Via Piani di Santa Maria, 72 - 00072 Ariccia (Rome) - Italy

Tel: (+39) 06 93 73 11 - Fax: (+39) 06 93 74 014

<http://www.daikinapplied.eu>