

Installer and user reference guide
Heat reclaim ventilation unit

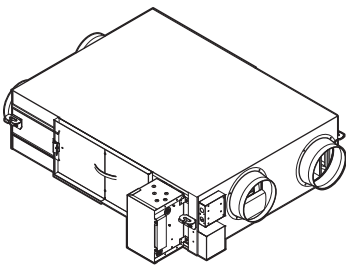

VAM350J ▲ VEB ▼
VAM500J ▲ VEB ▼
VAM650J ▲ VEB ▼
VAM800J ▲ VEB ▼
VAM1000J ▲ VEB ▼
VAM1500J ▲ VEB ▼
VAM2000J ▲ VEB ▼

▲ = 1, 2, 3, ..., 9, A, B, C, ..., Z
▼ = , , 1, 2, 3, ..., 9

Table of contents

1	About the documentation	5
1.1	About this document.....	5
1.2	Meaning of warnings and symbols	6
2	General safety precautions	8
2.1	For the installer	8
2.1.1	General.....	8
2.1.2	Installation site.....	9
2.1.3	Electrical.....	9
3	Specific installer safety instructions	12
For the user		16
4	User safety instructions	17
4.1	General	17
4.2	Instructions for safe operation	18
5	User interface	19
6	Operation	20
6.1	Before operation	20
6.2	Operation range	20
6.3	Ventilation mode.....	20
6.3.1	To set the ventilation mode	21
6.4	Ventilation rate.....	21
6.4.1	To set the ventilation rate	21
7	Energy saving and optimum operation	23
8	Maintenance and service	24
8.1	Maintenance of the air filter.....	24
8.2	Maintenance of the heat exchange element	26
9	Troubleshooting	27
10	Relocation	29
11	Disposal	30
For the installer		31
12	About the box	32
12.1	Heat reclaim ventilation unit	33
12.1.1	To unpack the heat reclaim ventilation unit	33
12.1.2	To remove the accessories	35
12.1.3	To handle the heat reclaim ventilation unit.....	36
13	About the units and options	37
13.1	Overview: About the units and options.....	37
13.2	Identification	37
13.2.1	Identification label: Heat reclaim ventilation unit	37
13.3	About the heat reclaim ventilation unit.....	38
13.3.1	About the EKVDX option	38
13.4	Combining units and options	39
13.4.1	Possible options for the heat reclaim ventilation unit.....	39
14	Unit installation	41
14.1	Preparing the installation site	41
14.1.1	Installation site requirements for the heat reclaim ventilation unit.....	41
14.2	Preparing the unit	41
14.2.1	To install the optional adapter PCB.....	42
14.2.2	To install the duct flanges.....	44
14.2.3	To install the EKVDX option	44
14.3	Unit orientation	45
14.4	To install the anchor bolts.....	46

14.5	Duct connections.....	47
15	Electrical installation	49
15.1	About connecting the electrical wiring.....	49
15.1.1	Precautions when connecting the electrical wiring.....	49
15.1.2	Guidelines when connecting the electrical wiring.....	50
15.1.3	Wiring connection.....	51
15.1.4	Component electrical specifications.....	52
15.1.5	Specifications for field supplied fuses and wires.....	53
15.2	Opening the switch box.....	54
15.3	Electrical connections for additional field supplied damper.....	61
15.4	To connect the electrical wiring.....	61
15.5	To connect the monitoring output.....	63
16	System configuration	64
16.1	About control systems.....	64
16.2	Independent system.....	65
16.3	Linked operation control system.....	65
16.4	Central control system.....	66
16.5	EKVDX option.....	67
17	Configuration	69
17.1	To change settings.....	69
	Case 1: Change settings with BRC1E53.....	70
	Case 2: Change settings with BRC301B61.....	71
	Case 3: Change settings with BRC1H.....	71
	Case 4: Change settings with BRC1K.....	72
17.2	Field settings.....	73
17.3	Settings for all configurations.....	75
17.3.1	About settings 19(29)-0-04 and 19(29)-0-05.....	76
17.3.2	Independent system.....	76
17.3.3	1-group linked-control system.....	77
17.3.4	Linked control with more than 2 groups.....	77
17.3.5	Direct duct connection.....	78
17.3.6	Central control system.....	79
17.3.7	EKVDX option - extra settings.....	82
17.4	About the controller.....	83
17.4.1	BRC1E53 controller.....	83
17.4.2	BRC301B61 controller.....	86
17.4.3	BRC1H controller.....	88
17.4.4	BRC1K controller.....	88
17.5	Detailed explanation of settings.....	89
17.5.1	About fresh-up operation.....	89
17.5.2	About the external damper operation.....	90
17.5.3	About the CO ₂ sensor.....	91
17.5.4	About nighttime free cooling operation.....	95
17.5.5	About the precool and preheat function.....	96
17.5.6	About preventing a feeling of draft.....	96
17.5.7	About 24-hour ventilation.....	96
17.5.8	About the ultra-low setting.....	96
17.5.9	About the electrical heater operation.....	97
17.5.10	About external linkage input.....	97
17.5.11	About filter contamination check.....	97
18	Commissioning	98
18.1	Overview: Commissioning.....	98
18.2	Checklist before commissioning.....	98
18.3	Checklist during commissioning.....	99
18.3.1	About the system test run.....	99
19	Hand-over to the user	100
20	Maintenance and service	101
20.1	Overview: Maintenance and service.....	101
20.2	Maintenance safety precautions.....	101
20.2.1	To prevent electrical hazards.....	101
20.3	Checklist for maintenance of the heat reclaim ventilation unit.....	102
21	Troubleshooting	103
21.1	Overview: Troubleshooting.....	103
21.2	Precautions when troubleshooting.....	103

Table of contents

21.3	Solving problems based on error codes	103
21.3.1	Error codes: Overview	103
22	Disposal	105
23	Technical data	106
23.1	Wiring diagram	106
23.2	Service space	109
24	Glossary	110

1 About the documentation

In this chapter

1.1	About this document.....	5
1.2	Meaning of warnings and symbols.....	6

1.1 About this document



INFORMATION

Make sure that the user has the printed documentation and ask him/her to keep it for future reference.

Target audience

Authorised installers + end users



INFORMATION

This appliance is intended to be used by expert or trained users in shops, in light industry and on farms, or for commercial use by lay persons.

Documentation set

This document is part of a documentation set. The complete set consists of:

- **General safety precautions:**

- Safety instructions that you **MUST** read before installing
- Format: Paper (in the accessory bag of the heat reclaim ventilation unit)

- **Heat reclaim ventilation unit installation and operation manual:**

- Installation and operation instructions
- Format: Paper (in the accessory bag of the heat reclaim ventilation unit)

- **Installer and user reference guide:**

- Preparation of the installation, good practices, reference data,...
- Detailed step-by-step instructions and background information for basic and advanced usage
- Format: Digital files on <https://www.daikin.eu>. Use the search function 🔍 to find your model.









The latest revision of the supplied documentation is published on the regional Daikin website and is available via your dealer.

The original instructions are written in English. All other languages are translations of the original instructions.





Technical engineering data

- A **subset** of the latest technical data is available on the regional Daikin website (publicly accessible).
- The **full set** of the latest technical data is available on the Daikin Business Portal (authentication required).

1.2 Meaning of warnings and symbols



	DANGER Indicates a situation that results in death or serious injury.
	DANGER: RISK OF ELECTROCUTION Indicates a situation that could result in electrocution.
	DANGER: RISK OF BURNING/SCALDING Indicates a situation that could result in burning/scalding because of extreme hot or cold temperatures.
	DANGER: RISK OF EXPLOSION Indicates a situation that could result in explosion.
	WARNING Indicates a situation that could result in death or serious injury.
	WARNING: FLAMMABLE MATERIAL
	CAUTION Indicates a situation that could result in minor or moderate injury.
	NOTICE Indicates a situation that could result in equipment or property damage.
	INFORMATION Indicates useful tips or additional information.

Symbols used on the unit:

Symbol	Explanation
	Before installation, read the installation and operation manual, and the wiring instruction sheet.
	Before performing maintenance and service tasks, read the service manual.
	For more information, see the installer and user reference guide.
	The unit contains rotating parts. Be careful when servicing or inspecting the unit.

Symbols used in the documentation:

Symbol	Explanation
	Indicates a figure title or a reference to it. Example: "▲ 1-3 Figure title" means "Figure 3 in chapter 1".

Symbol	Explanation
	Indicates a table title or a reference to it. Example: "  1-3 Table title" means "Table 3 in chapter 1".

2 General safety precautions

In this chapter

2.1	For the installer.....	8
2.1.1	General.....	8
2.1.2	Installation site.....	9
2.1.3	Electrical.....	9

2.1 For the installer

2.1.1 General

If you are NOT sure how to install or operate the unit, contact your dealer.



DANGER: RISK OF BURNING/SCALDING

- Do NOT touch the refrigerant piping, water piping or internal parts during and immediately after operation. It could be too hot or too cold. Give it time to return to normal temperature. If you MUST touch it, wear protective gloves.
- Do NOT touch any accidental leaking refrigerant.



WARNING

Improper installation or attachment of equipment or accessories could result in electrical shock, short-circuit, leaks, fire or other damage to the equipment. ONLY use accessories, optional equipment and spare parts made or approved by Daikin unless otherwise specified.



WARNING

Make sure installation, testing and applied materials comply with applicable legislation (on top of the instructions described in the Daikin documentation).



WARNING

Tear apart and throw away plastic packaging bags so that nobody, especially children, can play with them. **Possible consequence:** suffocation.



WARNING

Provide adequate measures to prevent that the unit can be used as a shelter by small animals. Small animals that make contact with electrical parts can cause malfunctions, smoke or fire.



CAUTION

Wear adequate personal protective equipment (protective gloves, safety glasses,...) when installing, maintaining or servicing the system.



CAUTION

Do NOT touch the air inlet or aluminium fins of the unit.



CAUTION

- Do NOT place any objects or equipment on top of the unit.
- Do NOT sit, climb or stand on the unit.

In accordance with the applicable legislation, it might be necessary to provide a logbook with the product containing at least: information on maintenance, repair work, results of tests, stand-by periods,...

Also, at least, following information **MUST** be provided at an accessible place at the product:

- Instructions for shutting down the system in case of an emergency
- Name and address of fire department, police and hospital
- Name, address and day and night telephone numbers for obtaining service

In Europe, EN378 provides the necessary guidance for this logbook.

2.1.2 Installation site

- Provide sufficient space around the unit for servicing and air circulation.
- Make sure the installation site withstands the weight and vibration of the unit.
- Make sure the area is well ventilated. Do NOT block any ventilation openings.
- Make sure the unit is level.

Do NOT install the unit in the following places:

- In potentially explosive atmospheres.
- In places where there is machinery that emits electromagnetic waves. Electromagnetic waves may disturb the control system, and cause malfunction of the equipment.
- In places where there is a risk of fire due to the leakage of flammable gases (example: thinner or gasoline), carbon fibre, ignitable dust.
- In places where corrosive gas (example: sulphurous acid gas) is produced. Corrosion of copper pipes or soldered parts may cause the refrigerant to leak.

2.1.3 Electrical



DANGER: RISK OF ELECTROCUTION

- Turn OFF all power supply before removing the switch box cover, connecting electrical wiring or touching electrical parts.
- Disconnect the power supply for more than 10 minutes, and measure the voltage at the terminals of main circuit capacitors or electrical components before servicing. The voltage **MUST** be less than 50 V DC before you can touch electrical components. For the location of the terminals, see the wiring diagram.
- Do NOT touch electrical components with wet hands.
- Do NOT leave the unit unattended when the service cover is removed.



WARNING

If NOT factory installed, a main switch or other means for disconnection, having a contact separation in all poles providing full disconnection under overvoltage category III condition, **MUST** be installed in the fixed wiring.



WARNING

- ONLY use copper wires.
- Make sure the field wiring complies with the national wiring regulations.
- All field wiring MUST be performed in accordance with the wiring diagram supplied with the product.
- NEVER squeeze bundled cables and make sure they do NOT come in contact with the piping and sharp edges. Make sure no external pressure is applied to the terminal connections.
- Make sure to install earth wiring. Do NOT earth the unit to a utility pipe, surge absorber, or telephone earth. Incomplete or incorrect earthing may cause electrical shock.
- Make sure to use a dedicated power circuit. NEVER use a power supply shared by another appliance.
- Make sure to install the required fuses or circuit breakers.
- Make sure to install an earth leakage protector. Failure to do so may cause electrical shock or fire.
- When installing the earth leakage protector, make sure it is compatible with the inverter (resistant to high frequency electric noise) to avoid unnecessary opening of the earth leakage protector.



WARNING

- After finishing the electrical work, confirm that each electrical component and terminal inside the switch box is connected securely.
- Make sure all covers are closed before starting up the unit.



CAUTION

- When connecting the power supply: connect the earth cable first, before making the current-carrying connections.
- When disconnecting the power supply: disconnect the current-carrying cables first, before separating the earth connection.
- The length of the conductors between the power supply stress relief and the terminal block itself MUST be as such that the current-carrying wires are tautened before the earth wire is in case the power supply is pulled loose from the stress relief.



NOTICE

Precautions when laying power wiring:



- Do NOT connect wiring of different thicknesses to the power terminal block (slack in the power wiring may cause abnormal heat).
- When connecting wiring which is the same thickness, do as shown in the figure above.
- For wiring, use the designated power wire and connect firmly, then secure to prevent outside pressure being exerted on the terminal board.
- Use an appropriate screwdriver for tightening the terminal screws. A screwdriver with a small head will damage the head and make proper tightening impossible.
- Over-tightening the terminal screws may break them.

Install power cables at least 1 meter away from televisions or radios to prevent interference. Depending on the radio waves, a distance of 1 meter may NOT be sufficient.



NOTICE

ONLY applicable if the power supply is three-phase, and the compressor has an ON/OFF starting method.

If there exists the possibility of reversed phase after a momentary black out and the power goes ON and OFF while the product is operating, attach a reversed phase protection circuit locally. Running the product in reversed phase can break the compressor and other parts.

3 Specific installer safety instructions

Always observe the following safety instructions and regulations.

Unit installation (see "14 Unit installation" [▶ 41])



WARNING

Fixing method of the heat reclaim ventilation unit MUST be in accordance with the instructions from this manual. See "14.4 To install the anchor bolts" [▶ 46].



WARNING

The appliance shall be stored in a room without continuously operating ignition sources (example: open flames, an operating gas appliance or an operating electric heater).



CAUTION

Appliance is NOT accessible to the general public. Install it in a secured area, protected from easy access.

This unit is suitable for installation in a commercial and light industrial environment.



WARNING

When connected to an EKVDX, the height of the air extraction opening from the room MUST be equal or below the refrigerant release point.



CAUTION

- The appliance is designed to be a built-in appliance. It may NOT be accessible to the general public. Adequate measures have to be taken to prevent access by other than qualified persons.
- Check if the installation location can support the unit's weight. Poor installation is hazardous. It can also cause vibrations or unusual operating noise.
- Provide sufficient service space and inspection holes. Inspection holes are needed for the air filters, the heat exchange elements and the fans.
- Do NOT install the unit so that it is in contact with a ceiling or wall, this may cause vibration.



CAUTION

- A minimum length of 1.5 m is required for the outdoor air, exhaust air and return air ducting. If the ducting is shorter, or if no ducting is installed, then you MUST install grilles in the duct openings or the openings of the unit.
- Make sure no wind can blow in the ducting.



WARNING

When combined with an EKVDX unit, do NOT install operating ignition sources (example: open flames, an operating gas appliance or an operating electric heater) in the duct work.

Electrical installation (see "15 Electrical installation" [▶ 49])



WARNING

Electrical wiring MUST be in accordance with the instructions from this manual. See "15 Electrical installation" [▶ 49].



WARNING

- All wiring **MUST** be performed by an authorised electrician and **MUST** comply with the national wiring regulation.
- Make electrical connections to the fixed wiring.
- All components procured on-site and all electrical construction **MUST** comply with the applicable legislation.



WARNING

- After finishing the electrical work, confirm that each electrical component and terminal inside the switch box is connected securely.
- Make sure all covers are closed before starting up the unit.



WARNING

If **NOT** factory installed, a main switch or other means for disconnection, having a contact separation in all poles providing full disconnection under overvoltage category III condition, **MUST** be installed in the fixed wiring.



WARNING

- **ONLY** use copper wires.
- Make sure the field wiring complies with the applicable legislation.
- All field wiring **MUST** be performed in accordance with the wiring diagram supplied with the product.
- **NEVER** squeeze bundled cables and make sure they do **NOT** come into contact with the piping and sharp edges. Make sure no external pressure is applied to the terminal connections.
- Make sure to install earth wiring. Do **NOT** earth the unit to a utility pipe, surge absorber, or telephone earth. Incomplete earthing may cause electrical shock.
- Make sure to install the required fuses or circuit breakers.
- Make sure to install an earth leakage protector. Failure to do so may cause electrical shock or fire.



CAUTION

Before opening the cover, be sure to turn off the power switches of the main units and other devices connected to the main units.

- Remove the screws that secure the cover and open the switch box.
- Secure the power supply cable and the control wire with a tie wrap, as shown in the figures.



WARNING

If a gap is present at the cable entry, wrap the cable (or cables) with the sealing material from the accessory bag.

This will prevent small objects (such as children's fingers, ... etc.) as well as fluid droplets from entering the unit.

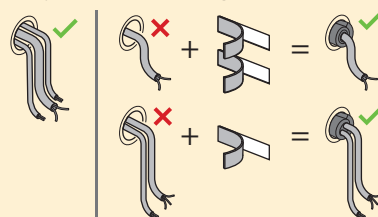



WARNING

Prevent hazards due to inadvertent resetting of the thermal cut-out: power to this appliance **MUST NOT** be supplied through an external switching device, such as a timer, or connected to a circuit that is regularly turned ON and OFF by the utility.



WARNING

- When carrying out an inspection on the switch box of the unit, **ALWAYS** make sure that the unit is disconnected from the mains. Turn off the respective circuit breaker.
- When a safety device was activated, stop the unit and find out why the safety device was activated before resetting it. **NEVER** shunt safety devices or change their values to a value other than the factory default setting. If you are unable to find the cause of the problem, call your dealer.



WARNING

- If the power supply has a missing or wrong N-phase, equipment might break down.
- Establish proper earthing. Do **NOT** earth the unit to a utility pipe, surge absorber, or telephone earth. Incomplete earthing may cause electrical shocks.
- Install the required fuses or circuit breakers.
- Secure the electrical wiring with cable ties so that the cables do **NOT** come in contact with sharp edges or piping, particularly on the high-pressure side.
- Do **NOT** install a phase advancing capacitor, because this unit is equipped with an inverter. A phase advancing capacitor will reduce performance and may cause accidents.



WARNING

Do **NOT** extend the power supply or the interconnection cable by using wire connectors, wire connection clamps, taped wires, extension cords. These can cause overheating, electric shock or fire.



WARNING

ALWAYS use multicore cable for power supply cables.



WARNING

Use an all-pole disconnection type breaker with at least 3 mm between the contact point gaps that provides full disconnection under overvoltage category III.



CAUTION

In case of combination with an EKVDX option using R32 refrigerant, do **NOT** turn off the circuit breaker, unless you smell something burning, or during a short repair period, inspection, or cleaning of the unit. Otherwise, R32 refrigerant leakage **CANNOT** be detected.



WARNING

If the supply cord is damaged, it **MUST** be replaced by the manufacturer, its service agent or similarly qualified persons in order to avoid a hazard.

Commissioning (see "18 Commissioning" [▶ 98])



WARNING

Commissioning **MUST** be in accordance with the instructions from this manual. See "18 Commissioning" [▶ 98].

For the user

4 User safety instructions

Always observe the following safety instructions and regulations.

In this chapter

4.1	General.....	17
4.2	Instructions for safe operation.....	18

4.1 General



WARNING

If you are NOT sure how to operate the unit, contact your installer.



WARNING

This appliance can be used by children aged from 8 years and above and persons with reduced physical, sensory or mental capabilities or lack of experience and knowledge if they have been given supervision or instruction concerning use of the appliance in a safe way and understand the hazards involved.

Children SHALL NOT play with the appliance.

Cleaning and user maintenance SHALL NOT be made by children without supervision.



WARNING

To prevent electrical shocks or fire:

- Do NOT rinse the unit.
- Do NOT operate the unit with wet hands.
- Do NOT place any objects containing water on the unit.



CAUTION

- Do NOT place any objects or equipment on top of the unit.
- Do NOT sit, climb or stand on the unit.

- Units are marked with the following symbol:



This means that electrical and electronic products may NOT be mixed with unsorted household waste. Do NOT try to dismantle the system yourself: dismantling the system, treatment of the refrigerant, of oil and of other parts MUST be done by an authorised installer and MUST comply with applicable legislation.

Units MUST be treated at a specialised treatment facility for reuse, recycling and recovery. By ensuring this product is disposed of correctly, you will help to prevent potential negative consequences for the environment and human health. For more information, contact your installer or local authority.

- Batteries are marked with the following symbol:



This means that the batteries may NOT be mixed with unsorted household waste. If a chemical symbol is printed beneath the symbol, this chemical symbol means that the battery contains a heavy metal above a certain concentration.

Possible chemical symbols are: Pb: lead (>0.004%).

Waste batteries MUST be treated at a specialised treatment facility for reuse. By ensuring waste batteries are disposed of correctly, you will help to prevent potential negative consequences for the environment and human health.

4.2 Instructions for safe operation



CAUTION

During operation, NEVER check or clean the unit. It may cause electrical shock. Do NOT touch the rotating parts, it will cause injury.



CAUTION

This unit is equipped with electrically powered safety measures that are required when connected to an EKVDX. In order to be effective, the installed unit MUST be electrically powered at all times, except for short service periods.



CAUTION

Before accessing, make sure to turn OFF the operation switch and disconnect the power.



WARNING

Stop operation and shut OFF the power if anything unusual occurs (burning smells etc.).

Leaving the unit running under such circumstances may cause breakage, electrical shock or fire. Contact your dealer.

5 User interface

This operation manual offers a non-exhaustive overview of the main functions of the system.

Detailed information on required actions to achieve certain functions can be found in the dedicated installation and operation manual of the indoor unit.

Refer to the operation manual of the installed controller.

6 Operation

In this chapter

6.1	Before operation	20
6.2	Operation range.....	20
6.3	Ventilation mode.....	20
6.3.1	To set the ventilation mode.....	21
6.4	Ventilation rate.....	21
6.4.1	To set the ventilation rate	21

6.1 Before operation



WARNING

This unit contains electrical parts.



WARNING

Before operating the unit, be sure the installation has been carried out correctly by an installer.



CAUTION



Do NOT operate the system when using a room fumigation-type insecticide. Chemicals could collect in the unit, and endanger the health of people who are hypersensitive to chemicals.

6.2 Operation range

Operation range	
Outdoor air + room air	
Temperature	-10°C DB~46°C DB
Relative humidity	≤80%
VAM unit location	
Temperature	0°C DB~40°C DB
Relative humidity	≤80%

6.3 Ventilation mode

The heat reclaim ventilation unit can operate in various operation modes.

Icon	Ventilation mode
	Energy Reclaim Ventilation. The outdoor air is supplied to the room after passing through a heat exchanger.
	Bypass. The outdoor air is supplied to the room without passing through a heat exchanger.
	Auto. To ventilate the room in the most efficient way, the heat reclaim ventilation unit automatically switches between "Bypass" and "Energy Reclaim Ventilation" mode (based on internal calculations).

**INFORMATION**

Depending on the heat reclaim ventilation unit, more or less ventilation modes are available.

**INFORMATION**

To ensure a smooth start, do not turn off the system while it is operating.

6.3.1 To set the ventilation mode

- 1 Navigate to the ventilation mode menu.



- 2 Use  and  to select a ventilation mode.



- 3 Press  to activate.

Result: The heat reclaim ventilation unit changes its operation mode and the controller returns to the home screen.

6.4 Ventilation rate

The ventilation rate is the fan speed during ventilation operation.

6.4.1 To set the ventilation rate

- 1 Navigate to the ventilation rate menu.



- 2 Use  and  to adjust the ventilation rate.

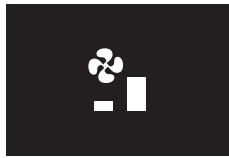

3 Press  to confirm.

Result: The heat reclaim ventilation unit changes its ventilation rate and the controller returns to the home screen.

7 Energy saving and optimum operation

Observe the following precautions to ensure the system operates properly.

- Adjust the air outlet properly and avoid direct air flow to room inhabitants.
- NEVER place objects near the air inlet or the air outlet of the unit. Doing so may cause a reduced heating/cooling effect or stop operation.
- When the display shows  (time to clean the air filter), ask a qualified service person to clean the filters. Refer to "[8 Maintenance and service](#)" [▶ 24].
- Keep the heat reclaim ventilation unit and controller at least 1 m away from televisions, radios, stereos, and other similar equipment. Failure to do so may cause static or distorted pictures.
- Do NOT place items under the indoor unit, as they may be damaged by water.
- Condensation may form if the humidity is above 80%.

If the heat reclaim ventilation unit is used in a linked or a central control system, then energy saving functionality is available. Refer to "[17.5 Detailed explanation of settings](#)" [▶ 89].

Contact your installer or dealer for advice or to modify the parameters to the needs of your building.

Detailed information is given for the installer in the installation manual.

8 Maintenance and service



CAUTION

See "4 User safety instructions" [▶ 17] to acknowledge all related safety instructions.



NOTICE

Maintenance **MUST** be done by an authorised installer or service agent.

We recommend performing maintenance at least once a year. However, applicable legislation might require shorter maintenance intervals.



NOTICE

We recommend to clean at least once every 2 years (for general office use). If necessary, shorter maintenance intervals might be required.

In this chapter

8.1	Maintenance of the air filter	24
8.2	Maintenance of the heat exchange element.....	26

8.1 Maintenance of the air filter



NOTICE

- Do NOT wash the air filter in hot water.
- Do NOT dry the air filter over a fire.
- Do NOT subject the air filter to direct sunlight.
- Do NOT use organic solvents, such as gasoline or thinner, on the air filter.
- Make sure to install the air filter after servicing (missing air filter causes clogged heat exchange element). Replacement air filters are available.

To clean the air filters

- 1 Go into the ceiling through the inspection hole, loosen the screw of the hinge mechanism (on the left side) to open the service cover. Take the service cover off by rotating it around the vertical axis of the hanging metal.

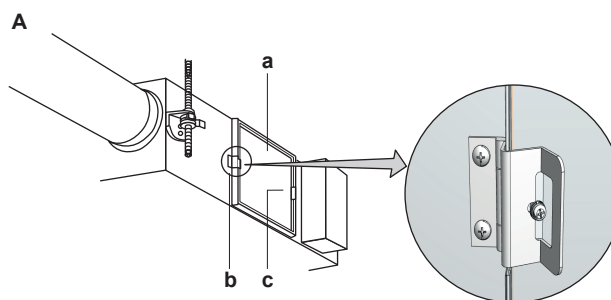

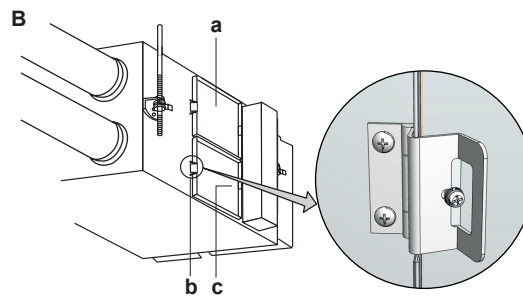

- a Service cover
- b Hinge mechanism
- c Hanging metal
- A Models 350~1000
- B Models 1500+2000

2 Take out the air filters from the unit body.

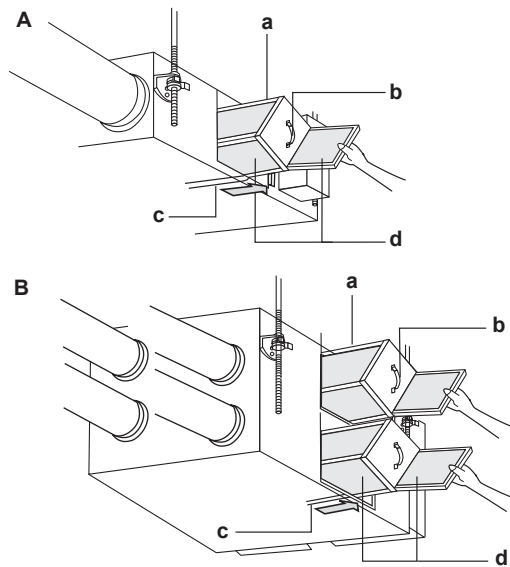

- a Heat exchange element
- b Handle
- c Rail
- d Air filter
- A Models 350~1000
- B Models 1500+2000

3 To clean the air filter, lightly pat it with your hand or remove dust with a vacuum cleaner. If excessively dirty, wash it in water.

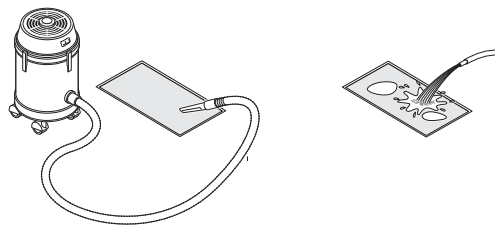

- 4** If the air filter is washed, remove water completely and allow to dry for 20 to 30 minutes in the shade.
- 5** When dried completely, install the air filter back in place after the installation of the heat exchange element. Make sure the air filter is orientated correctly, as shown in the figure.

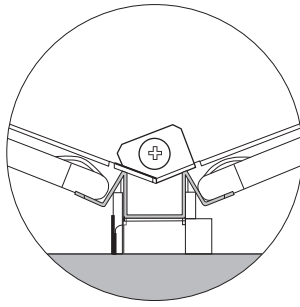

- 6 Install the service cover securely in place.

8.2 Maintenance of the heat exchange element



NOTICE

- NEVER wash the heat exchange element with water.
- NEVER touch the heat exchange element paper because it can be damaged if it is forced.
- Do NOT crush the heat exchange element.

To clean the heat exchange element

- 1 Take out the heat exchange elements. Refer to "[8.1 Maintenance of the air filter](#)" [▶ 24].
- 2 Equip a vacuum cleaner with a brush on the end of the suction nozzle.
- 3 Use the vacuum cleaner and lightly apply the brush to the surface of the heat exchange element to remove dust.

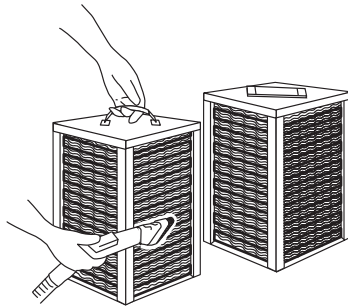

- 4 Place the heat exchange element on the rail and insert it in the unit.
- 5 Install the air filters in the unit.
- 6 Install the service cover.

9 Troubleshooting

If one of the following malfunctions occurs, take the measures shown below and contact your dealer.

The system **MUST** be repaired by a qualified service person.

Malfunction	Measure
If a safety device such as a fuse, a breaker or an earth leakage breaker frequently actuates or the ON/OFF switch does NOT properly work.	Turn OFF the main power switch.
If water leaks from the unit.	Stop the operation.
The operation switch does NOT work well.	Turn OFF the power supply.
If the controller display indicates the unit number, the operation lamp flashes and the malfunction code appears.	Notify your installer and report the malfunction code.

If the system does NOT operate properly except for the above mentioned cases and none of the above mentioned malfunctions is evident, investigate the system in accordance with the following procedures.

Malfunction	Measure
The system does NOT operate at all.	<ul style="list-style-type: none"> ▪ Check if there is no power failure. Wait until power is restored and restart operation. ▪ Check if no fuse has blown or breaker is activated. Change the fuse or reset the breaker if necessary. ▪ Check if the indication of the operation control method on the controller is shown. This is normal. Operate the unit using the air conditioner remote control or the central controller. Refer to "17 Configuration" [▶ 69]. ▪ Check if the indication of operation standby is displayed on the controller, indicating that the unit is precooling/preheating. The unit is at stop and will start operation after the precooling/preheating operation is completed. Refer to "17 Configuration" [▶ 69].
The amount of discharged air is small and the discharging sound is high.	<ul style="list-style-type: none"> ▪ Check if the air filter and heat exchange element are NOT clogged. Refer to "8 Maintenance and service" [▶ 24].
The amount of discharged air is large and the discharging sound is high.	<ul style="list-style-type: none"> ▪ Check if the air filter and heat exchange element are installed. Refer to "8 Maintenance and service" [▶ 24].



INFORMATION

The unit may not operate as requested due to a filter contamination check.

In case a malfunction code appears on the indoor unit controller display, contact your installer and inform the malfunction code, the unit type, and serial number (you can find this information on the nameplate of the unit).

For your reference, a list with malfunction codes is provided. Refer to "[21.3.1 Error codes: Overview](#)" [▶ 103]. Depending on the level of the malfunction code, the

code can be reset by pushing the ON/OFF button. If NOT, ask your installer for advice.



INFORMATION

The preheating/precooling function of the heat reclaim ventilation unit is disabled when it is connected to an EKVDX.

After checking all the items above, if it is impossible to fix the problem yourself, contact your installer and state the symptoms, the complete model name of the unit (with manufacturing number if possible) and the installation date.

10 Relocation

Contact your dealer to remove and reinstall the entire unit. Moving units requires technical expertise.

11 Disposal



NOTICE

Do NOT try to dismantle the system yourself: dismantling of the system, treatment of the refrigerant, oil and other parts MUST comply with applicable legislation. Units MUST be treated at a specialised treatment facility for reuse, recycling and recovery.

For the installer

12 About the box

Keep the following in mind:

- At delivery, the unit **MUST** be checked for damage and completeness. Any damage or missing parts **MUST** be reported immediately to the claims agent of the carrier.
- Bring the packed unit as close as possible to its final installation position to prevent damage during transport.
- Prepare in advance the path along which you want to bring the unit to its final installation position.
- When handling the unit, take into account the following:



Fragile.



Keep the unit upright in order to avoid compressor damage.

In this chapter

12.1	Heat reclaim ventilation unit.....	33
12.1.1	To unpack the heat reclaim ventilation unit	33
12.1.2	To remove the accessories	35
12.1.3	To handle the heat reclaim ventilation unit	36

12.1 Heat reclaim ventilation unit

12.1.1 To unpack the heat reclaim ventilation unit

Models 350+500

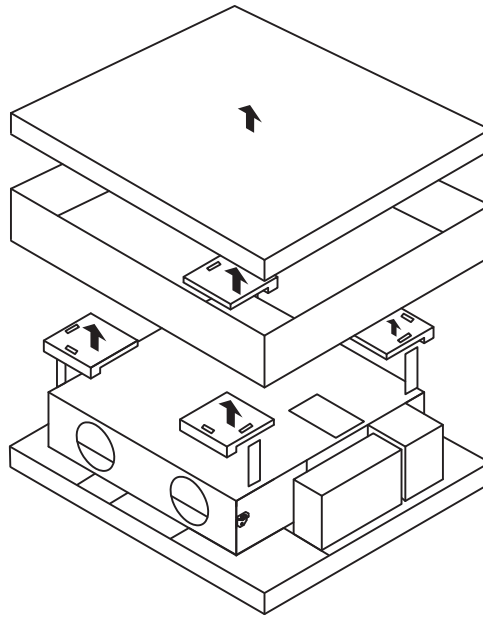

Models 650~1000

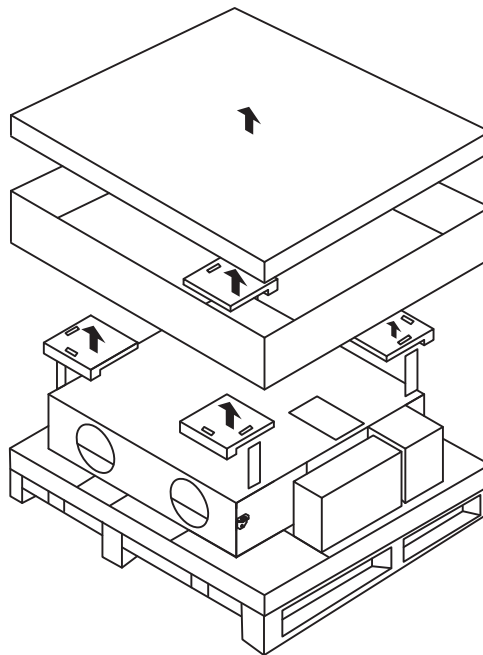

Models 1500+2000

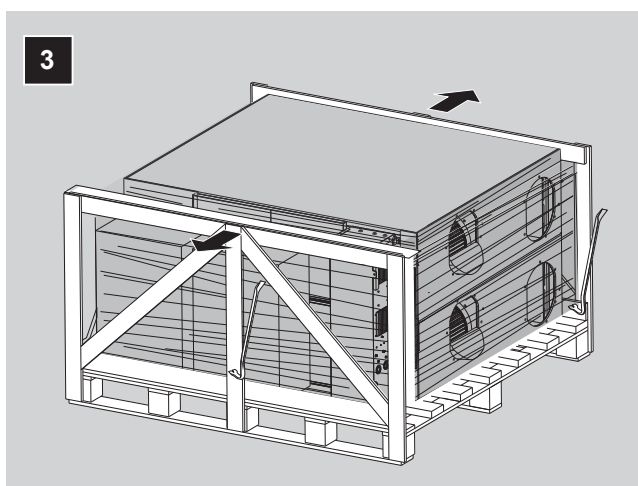
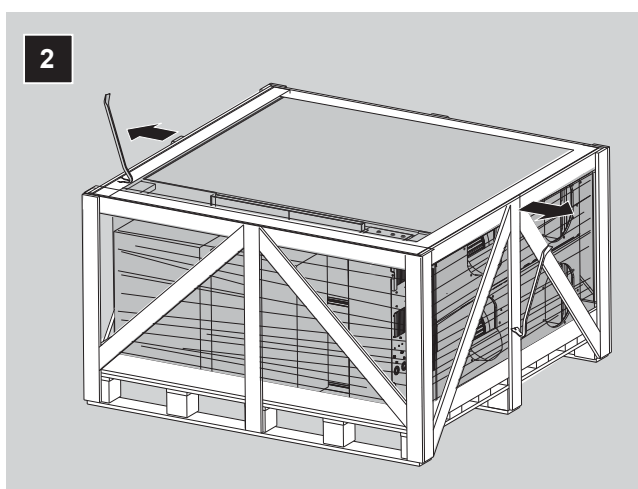
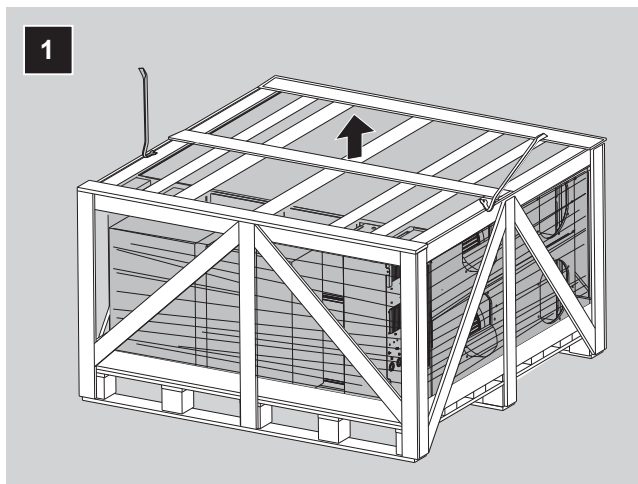

12.1.2 To remove the accessories

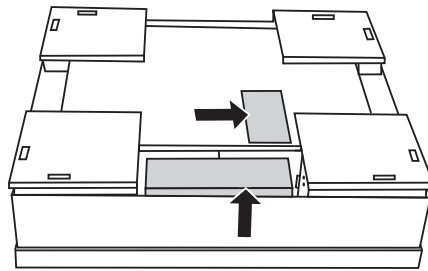
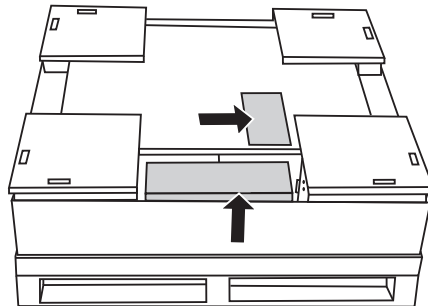
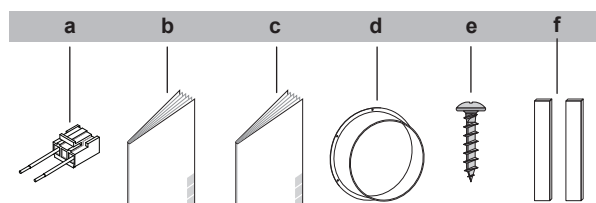
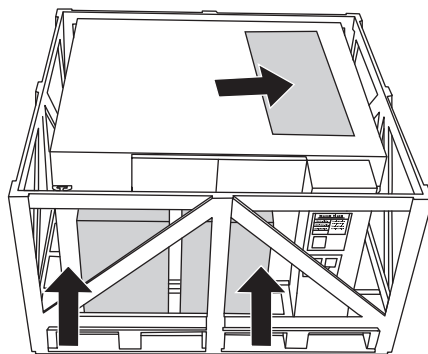
Models 350+500**Models 650~1000****Models 1500+2000**

- a** Connector for additional external damper
- b** General safety precautions
- c** Installation and operation manual
- d** Duct flanges (models 350~1000 4x, models 1500+2000 8x)
- e** Screws (models 350+500 16x, models 650~1000 24x, models 1500+2000 48x)
- f** Seal strips for cables (switchbox cable entry)

12.1.3 To handle the heat reclaim ventilation unit



NOTICE

When removing the heat reclaim ventilation unit from the packaging, do NOT place the suction or discharge side of the unit on the floor. **Possible consequence:** Deformation of the suction or discharge openings and damaged expanded polystyrene parts of the unit.



CAUTION

To avoid injury, do NOT touch the air inlet, the air outlet, or the fans of the unit.

▪ **With packaging.**

In case of models 350+500, do NOT use slings or a forklift.

In case of models 650~2000, use a forklift.

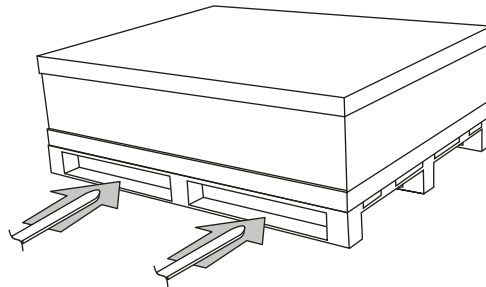

▪ **Without packaging.**

Carry models 350~1000 carefully as shown:

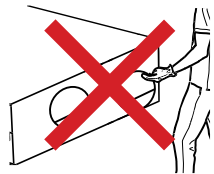
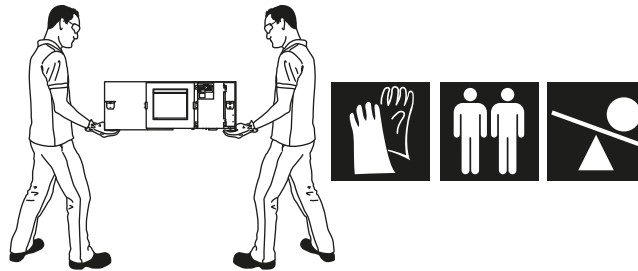

Carry models 1500+2000 carefully as shown:



13 About the units and options

In this chapter

13.1	Overview: About the units and options	37
13.2	Identification.....	37
13.2.1	Identification label: Heat reclaim ventilation unit.....	37
13.3	About the heat reclaim ventilation unit.....	38
13.3.1	About the EKVDX option	38
13.4	Combining units and options	39
13.4.1	Possible options for the heat reclaim ventilation unit.....	39

13.1 Overview: About the units and options

This chapter contains information about:

- Identifying the unit
- Combining the unit with options

13.2 Identification



NOTICE

When installing or servicing several units at the same time, make sure NOT to switch the service panels between different models.

13.2.1 Identification label: Heat reclaim ventilation unit

Location

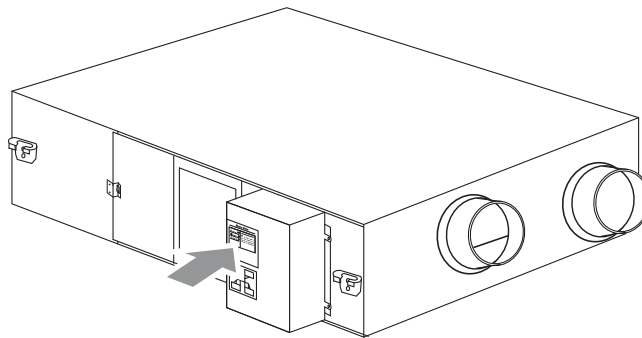

Model identification

Example: V A M 500 J 8 VE B [*]

Code	Explanation
V	Ventilation
A	Air
M	Mounted type
500	Nominal air flow rate (m ³ /h)
J	Major design category (design category for EC application)
8	Minor design category
VE	Power supply: 1~, 50 Hz 220~240 V Power supply: 1~, 60 Hz 220 V

Code	Explanation
B	European market
[*]	Minor model change indication

13.3 About the heat reclaim ventilation unit

The heat reclaim ventilation unit is intended for indoor installation.



NOTICE

ALWAYS use the air filters. If the air filters are NOT used, the heat exchange elements can get clogged, possibly causing poor performance and subsequent failure.

Operation range	
Outdoor air + room air	
Temperature	-10°C DB~46°C DB
Relative humidity	≤80%
VAM unit location	
Temperature	0°C DB~40°C DB
Relative humidity	≤80%

It is possible that, due to condensation, the paper heat exchanger deteriorates when the unit operates in conditions with high indoor humidity combined with low outdoor temperature. If such combined conditions occur for an extended period of time, the necessary precautions must be taken to prevent condensation. Example: install a preheater to heat up outdoor air.

When the heat reclaim ventilation unit is installed upside down, the minimum allowed outdoor air temperature is 5°C. If this cannot be guaranteed, you MUST install a heater to heat up the outdoor air to 5°C.

13.3.1 About the EKVDX option

The EKVDX option is an airconditioning unit for the pretreatment of incoming supply air from a VAM heat reclaim ventilation unit. For comfort temperature control, it is still required to install a normal indoor unit.

EKVDX units are available:

- for models VAM500~2000J*.
- with refrigerants R32 or R410A.

In case an EKVDX is installed, after setting the field settings on the EKVDX, make sure to set the appropriate field settings on the VAM. See "[17.2 Field settings](#)" [▶ 73].



INFORMATION

When connected to an EKVDX, the minimum airflow during normal operation or during the refrigerant leakage detection is always >240 m³/h.

13.4 Combining units and options



INFORMATION

Certain options may NOT be available in your country.

13.4.1 Possible options for the heat reclaim ventilation unit

Adapter PCB

Options BRP4A50A and KRP2A51.

At temperatures below -10°C , it is mandatory to use an electrical pre-heater. This heater is connected with option PCB BRP4A50A.



CAUTION

If an electrical heater is installed, use non-flammable duct. For safety reasons, be sure to keep a distance of at least 2 m between the heater and the heat reclaim ventilation unit.

For model 650: the optional mounting plate (EKMP65VAM) is required.

For models 1500 and 2000: the optional mounting plate (EKMPVAM) is required.

When installing option KRP2A51, the optional installation box (KRP1BA101) is required.

Filter

This option may be mandatory. Check the local legislation. It is recommended in places with poor outside air quality.

Install the filter behind the heat exchange element either at the supply air side or at the exhaust air side. Keep the standard filter in place. Remove the standard filter ONLY when installing an option filter both in front of and behind the heat exchange element.

For installation instructions, see the installation manual of the filter kit.

Pressure drop over the filter ^(a)				
Model	Filter class	350+500	650	800~2000
EKAFVJ50F6	M6	●	—	—
EKAFVJ50F7	F7	●	—	—
EKAFVJ50F8	F8	●	—	—
EKAFVJ65F6	M6	—	●	—
EKAFVJ65F7	F7	—	●	—
EKAFVJ65F8	F8	—	●	—
EKAFVJ100F6	M6	—	—	●
EKAFVJ100F7	F7	—	—	●
EKAFVJ100F8	F8	—	—	●

^(a) See the databook for pressure drop curves for each capacity class of unit and each class of filter.

Plenum (EKPLEN200)

The plenum is an option for models 1500 and 2000. This option can be used to ease the installation of the heat reclaim ventilation unit.

Replace the 2 duct joints of $\varnothing 250$ mm with the plenum and a duct joint of $\varnothing 350$ mm.

For installation instructions, see the installation manual of the plenum kit.

EKVDX module

The EKVDX module is an option for the heat reclaim ventilation unit. It can be used to heat up or cool down fresh, outdoor air coming from the heat reclaim ventilation unit, for lower load on the air conditioning system.

For more information, see "[16.5 EKVDX option](#)" [▶ 67].

Use the table to make the correct selection between the capacities of the heat reclaim ventilation unit and the EKVDX.

	EKVDX32	EKVDX50	EKVDX80	EKVDX100
VAM500J*	●	—	—	—
VAM650J*	—	●	—	—
VAM800J*	—	●	—	—
VAM1000J*	—	—	●	—
VAM1500J*	—	—	—	●
VAM2000J*	—	—	—	●

- Not compatible
- Compatible in pair

CO₂ sensor (BRYMA*)

The CO₂ sensor is optional. This option can be used to adapt the ventilation rate to the CO₂ concentration.

Install the CO₂ sensor in the heat reclaim ventilation unit. For models 1500+2000, install the CO₂ sensor in the top heat reclaim ventilation unit.

For installation instructions, see "[17.5.3 About the CO₂ sensor](#)" [▶ 91].

14 Unit installation

In this chapter

14.1	Preparing the installation site	41
14.1.1	Installation site requirements for the heat reclaim ventilation unit	41
14.2	Preparing the unit	41
14.2.1	To install the optional adapter PCB	42
14.2.2	To install the duct flanges	44
14.2.3	To install the EKVDX option	44
14.3	Unit orientation	45
14.4	To install the anchor bolts	46
14.5	Duct connections	47

14.1 Preparing the installation site

Choose an installation location with sufficient space to transport the unit in and out of the site.

Do NOT install the unit in places often used as work place. In case of construction works (e.g. grinding works) where a lot of dust is created, the unit MUST be covered.

Do NOT install a heat reclaim ventilation unit or air suction/discharge grille in the following places:

- Places, such as machinery plants and chemical plants, where noxious gases or corrosive components of materials such as acid, alkali, organic solvent and paint are present.
- Places, such as bathrooms, subject to moisture. Moisture can cause electrical shock, electric leakage and other failures.
- Places subject to high temperature or direct flames.
- Places subject to much soot. Soot clings to air filter and heat exchange elements, disabling them.

14.1.1 Installation site requirements for the heat reclaim ventilation unit



CAUTION

See "[3 Specific installer safety instructions](#)" [▶ 12] to make sure this installation complies with all safety regulations.

Service space

See "[23.2 Service space](#)" [▶ 109].

14.2 Preparing the unit



CAUTION

See "[3 Specific installer safety instructions](#)" [▶ 12] to make sure this installation complies with all safety regulations.

**INFORMATION**

- Flexible ducting with sound insulation is effective to reduce blowing noises.
- When selecting installation materials, consider the required volume of air flow and the acceptable level of noise for that particular installation.
- When room air infiltrates into the ceiling and the temperature and humidity in the ceiling become too high, insulate the metal parts of the unit.
- ONLY use the inspection hole to access the inside of the unit.
- The sound pressure level is less than 70 dBA.

14.2.1 To install the optional adapter PCB

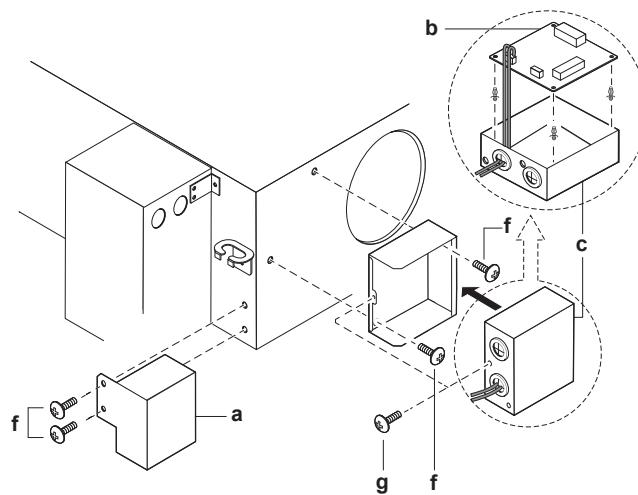
For models 350-500-800-1000

- a** BRP4A50A (optional accessory)
- b** KRP2A51 (optional accessory)
- c** KRP1BA101 (installation box)
- f** Screw
- g** Screw (supplied with the installation box)

- 1** Remove the screws from the unit.
- 2** Attach the optional adapter PCB (KRP2A51) in the installation box (KRP1BA101).
- 3** Follow the installation instructions provided with the option kits (BRP4A50A, KRP2A51 and KRP1BA101).
- 4** Guide the PCB wire through the dedicated holes and attach it as instructed in ["15.2 Opening the switch box" \[▶ 54\]](#).
- 5** Attach the options to the unit, as shown in the figure.
- 6** After the wires are connected, fasten the switch box cover.

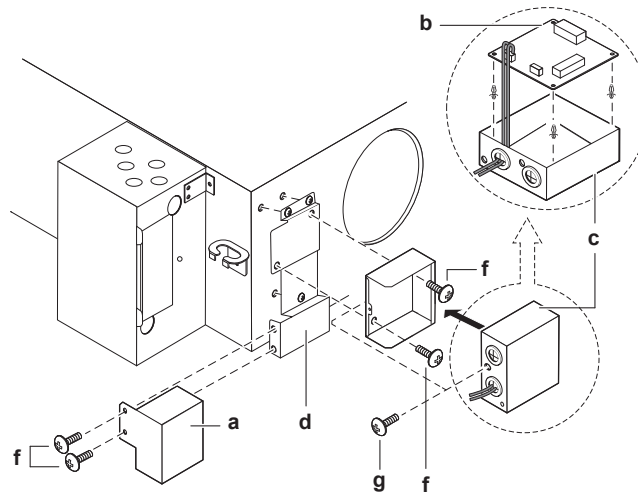
For model 650

- a BRP4A50A (optional accessory)
- b KRP2A51 (optional accessory)
- c KRP1BA101 (installation box)
- d EKMP65VAM (mounting plate)
- f Screw
- g Screw (supplied with the installation box)

- 1 Remove the screws from the unit.
- 2 Attach the optional mounting plate (EKMP65VAM) to the unit.
- 3 Attach the optional adapter PCB (KRP2A51) in the installation box (KRP1BA101).
- 4 Follow the installation instructions provided with the option kits (BRP4A50A, KRP2A51 and KRP1BA101).
- 5 Guide the PCB wire through the dedicated holes and attach it as instructed in "[15.2 Opening the switch box](#)" [▶ 54].
- 6 Attach the options to the optional mounting plate, as shown in the figure.
- 7 After the wires are connected, fasten the switch box cover.

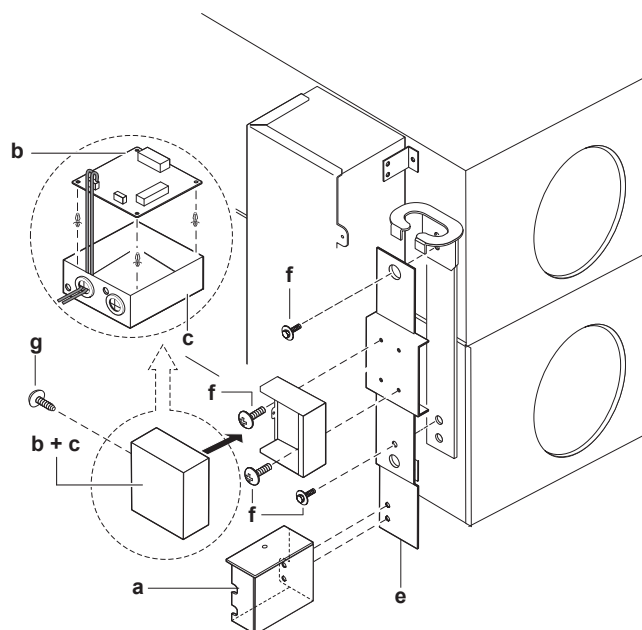
For models 1500+2000

- a BRP4A50A (optional accessory)
- b KRP2A51 (optional accessory)

- c** KRP1BA101 (installation box)
- d** EKMP65VAM (mounting plate)
- f** Screw
- g** Screw (supplied with the installation box)

- 1** Remove the screws from the middle of the plate connecting the 2 units.
- 2** Attach the optional mounting plate (EKMPVAM) on top of the plate connecting the 2 units.
- 3** Attach the optional adapter PCB (KRP2A51) in the installation box (KRP1BA101).
- 4** Follow the installation instructions provided with the option kits (BRP4A50A, KRP2A51 and KRP1BA101).
- 5** Guide the PCB wire through the dedicated holes and attach it as instructed in "15.2 Opening the switch box" [▶ 54].
- 6** Attach the options to the optional mounting plate, as shown in the figure.
- 7** After the wires are connected, fasten the switch box cover.

14.2.2 To install the duct flanges

- 1** Position the duct flanges (a) over the duct holes.
- 2** Secure the duct flanges with the provided screws (b) (see accessory bag).

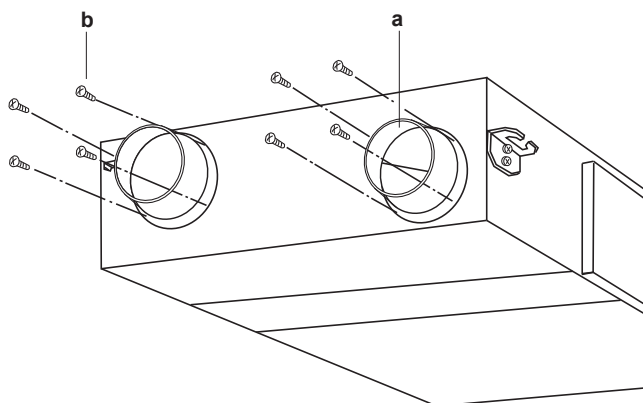

- a** Duct flange
- b** Screw

Model	Required screws	Duct flanges
VAM350	16	4× Ø200 mm
VAM500	16	4× Ø200 mm
VAM650	24	4× Ø250 mm
VAM800	24	4× Ø250 mm
VAM1000	24	4× Ø250 mm
VAM1500	48	8× Ø250 mm
VAM2000	48	8× Ø250 mm

14.2.3 To install the EKVDX option

See "17.2 Field settings" [▶ 73].

For more information, see the Installation and operation manual of the EKVDX.

14.3 Unit orientation

The following illustration helps you to install the heat reclaim ventilation unit in the correct position:

Normal installation

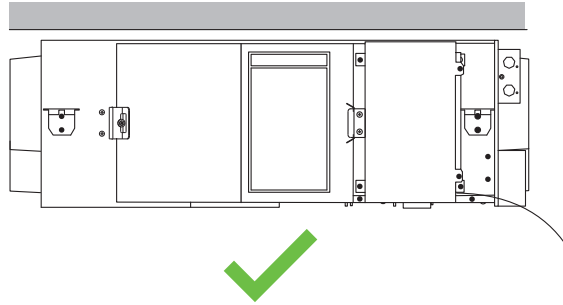

Upside down installation

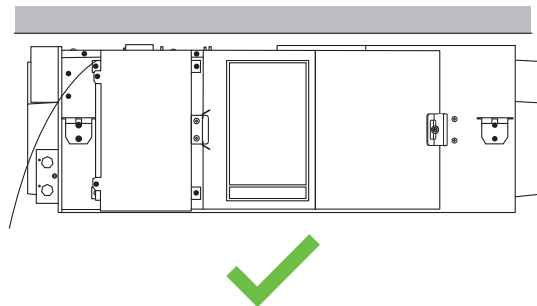

Vertical installation

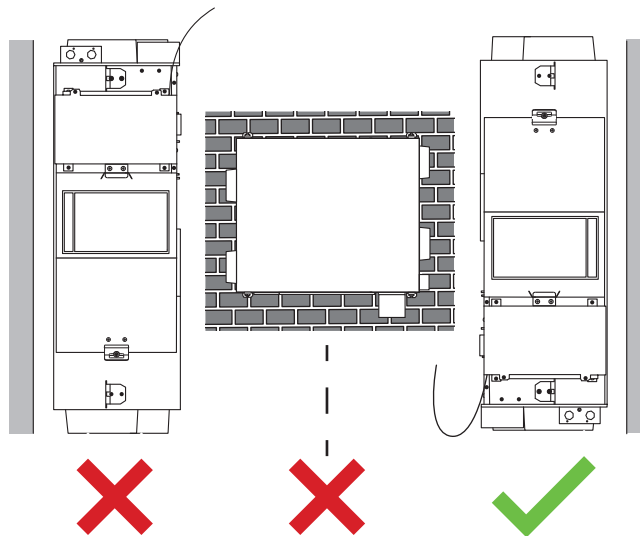

INFORMATION

When the unit is installed vertically, the installer **MUST** provide a support under the unit to distribute the weight of the unit between the support and the installation bolts in the wall.



NOTICE

When the heat reclaim ventilation unit is installed vertically in low outdoor temperature conditions, dewing or freezing may occur. If such operating conditions are to be expected, take the appropriate precautions, e.g. install an electrical heater.

Installation tips

- Installing the unit upside down allows for common use of the inspection hole, thus reducing the required maintenance space. For example, if 2 units are installed closely together, only 1 inspection hole is required for maintaining or replacing filters, heat exchange elements,...

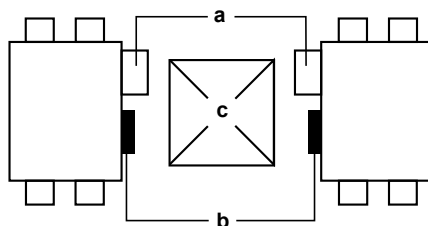

- a Control box
- b Service cover
- c Inspection hole

- Keep in mind that the ceiling hooks MUST be rotated 180° when the heat reclaim ventilation unit is installed upside down (see the figure).

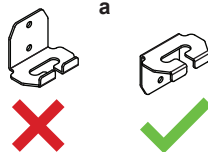
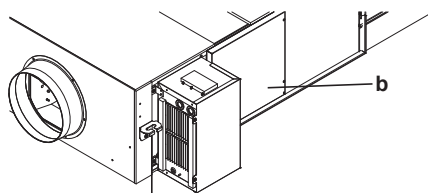

- a Ceiling hook
- b Service cover

14.4 To install the anchor bolts

Prerequisite: Before installing the anchor bolts, remove any foreign objects, such as vinyl and paper, from the inside of the fan housing.

- 1 Install the anchor bolts (M10 to M12).
- 2 Pass the metal suspension brackets over the anchor bolts.
- 3 Secure the anchor bolts with washer and nut.

For models 350~1000

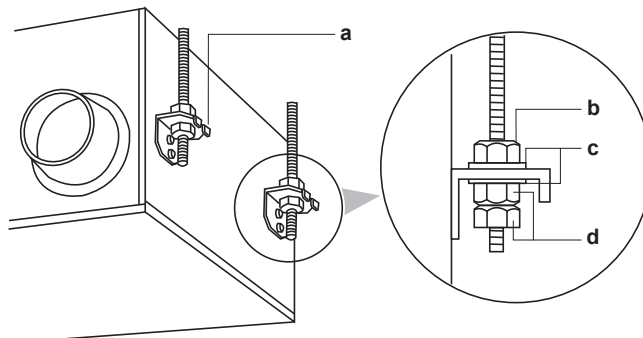

For models 1500+2000

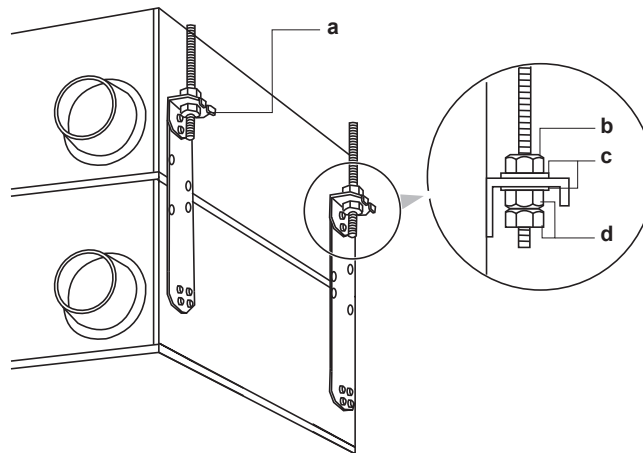

- a Ceiling hook
- b Nut
- c Washer
- d Double nut

**NOTICE**

ALWAYS hang up the unit by its suspension brackets.

14.5 Duct connections

Do NOT connect the ducts as follows:

Extreme bend. Do NOT bend the duct more than 90°.	
Multi bend	
Reduced diameter. Do NOT reduce the duct diameter.	

- The minimum bend radius for flexible ducts is as follows: $(\varnothing_{\text{duct}}/2) \times 1.5$
- To prevent air leakage, wind aluminium tape around the section where the duct flanges and the ducts are connected.
- Install the opening of the supply air as far as possible from the opening of the room air.
- Use ducts with a diameter that fits the unit model. See the data book.
- Install the two outdoor ducts with a downward slope (minimum 1:50) to prevent entry of rain water. Also provide insulation for both ducts, to prevent dew formation. (Insulation material: 25 mm thick glass wool)
- If the temperature and humidity levels inside the ceiling are always high, install ventilation inside the ceiling.
- Insulate the duct and the wall electrically when a metal duct has to penetrate the metal lattice and wire lattice or the metal lining of a wooden structure wall.
- Install the ducts in such a way that the wind CANNOT blow inside the ducting.

- All 4 ducts MUST have a length ≥ 1.5 m (exception: VAM in combination with optional EKVDX, see EKVDX operation and installation manual).

Models 350~1000

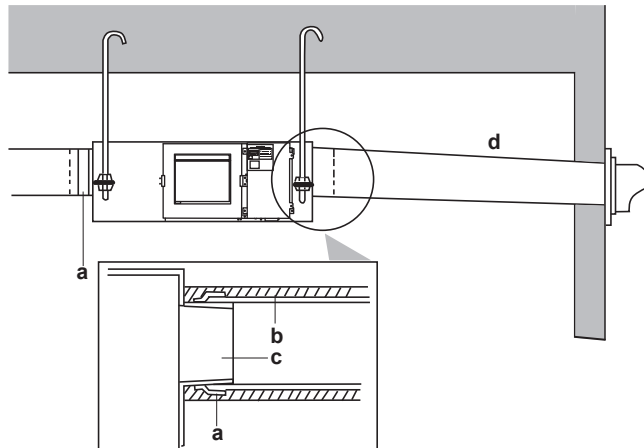

Models 1500+2000

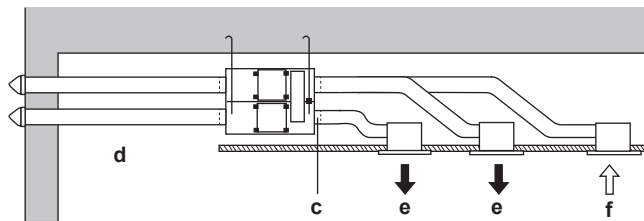

- a Aluminium tape (field supply)
- b Insulation material (field supply)
- c Duct flange (accessories)
- d Slope minimum 1:50
- e Supply air
- f Room air



INFORMATION

For more information about duct connections in combination with an EKVDX module, refer to the installer and user reference guide of the EKVDX unit.

15 Electrical installation



CAUTION

See "3 Specific installer safety instructions" [▶ 12] to make sure this installation complies with all safety regulations.

In this chapter

15.1	About connecting the electrical wiring	49
15.1.1	Precautions when connecting the electrical wiring	49
15.1.2	Guidelines when connecting the electrical wiring	50
15.1.3	Wiring connection.....	51
15.1.4	Component electrical specifications.....	52
15.1.5	Specifications for field supplied fuses and wires.....	53
15.2	Opening the switch box.....	54
15.3	Electrical connections for additional field supplied damper	61
15.4	To connect the electrical wiring.....	61
15.5	To connect the monitoring output.....	63

15.1 About connecting the electrical wiring

15.1.1 Precautions when connecting the electrical wiring



DANGER: RISK OF ELECTROCUTION



WARNING

- All wiring **MUST** be performed by an authorised electrician and **MUST** comply with the national wiring regulation.
- Make electrical connections to the fixed wiring.
- All components procured on-site and all electrical construction **MUST** comply with the applicable legislation.



WARNING

ALWAYS use multicore cable for power supply cables.



INFORMATION

Also read the precautions and requirements in the "2 General safety precautions" [▶ 8].



WARNING

- If the power supply has a missing or wrong N-phase, equipment might break down.
- Establish proper earthing. Do **NOT** earth the unit to a utility pipe, surge absorber, or telephone earth. Incomplete earthing may cause electrical shocks.
- Install the required fuses or circuit breakers.
- Secure the electrical wiring with cable ties so that the cables do **NOT** come in contact with sharp edges or piping, particularly on the high-pressure side.
- Do **NOT** install a phase advancing capacitor, because this unit is equipped with an inverter. A phase advancing capacitor will reduce performance and may cause accidents.

 **CAUTION**
Do NOT push or place redundant cable length into the unit.

 **WARNING**
Do NOT extend the power supply or the interconnection cable by using wire connectors, wire connection clamps, taped wires, extension cords. These can cause overheating, electric shock or fire.

15.1.2 Guidelines when connecting the electrical wiring

 **NOTICE**
We recommend using solid (single-core) wires. If stranded wires are used, slightly twist the strands to consolidate the end of the conductor for either direct use in the terminal clamp or insertion in a round crimp-style terminal.

To prepare stranded conductor wire for installation

Method 1: Twisting conductor

- 1 Strip insulation (20 mm) from the wires.
- 2 Slightly twist the end of the conductor to create a "solid-like" connection.

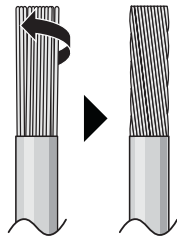

Method 2: Using round crimp-style terminal (recommended)

- 1 Strip insulation from wires and slightly twist the end of each wire.
- 2 Install a round crimp-style terminal on the end of the wire. Place the round crimp-style terminal on the wire up to the covered part and fasten the terminal with the appropriate tool.

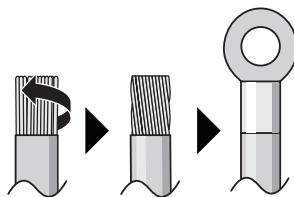

Use the following methods for installing wires:

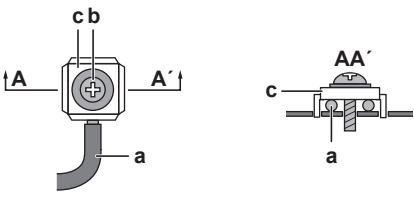
Wire type	Installation method
Single-core wire Or Stranded conductor wire twisted to "solid-like" connection	 <p>The diagram shows two installation methods. The first method shows a wire (labeled 'a') being inserted into a terminal block (labeled 'A' and 'A'') and secured with a screw (labeled 'b') and a flat washer (labeled 'c'). The second method shows a wire (labeled 'a') being inserted into a terminal block (labeled 'AA'' and 'c') and secured with a screw (labeled 'b') and a flat washer (labeled 'c').</p> <p>a Curled wire (single-core or twisted stranded conductor wire) b Screw c Flat washer</p>

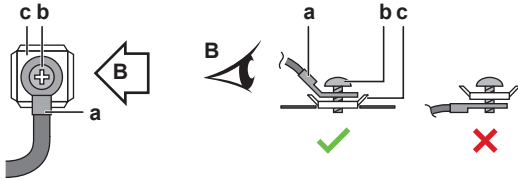
Wire type	Installation method
Stranded conductor wire with round crimp-style terminal	 <p>a Terminal b Screw c Flat washer ✓ Allowed ✗ NOT allowed</p>

For earth connections, use the following method:

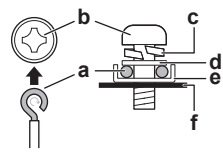
Wire type	Installation method
Single-core wire Or Stranded conductor wire twisted to "solid-like" connection	 <p>a Clockwise curled wire (single-core or twisted stranded conductor wire) b Screw c Spring washer d Flat washer e Coupling washer f Sheet metal</p>

15.1.3 Wiring connection



WARNING

A main switch or other means for disconnection, having a contact separation in all poles, MUST be incorporated in the fixed wiring in accordance with the applicable legislation.

You can use a single switch to supply power to units on the same system. However, branch switches and branch circuit breakers MUST be selected carefully.

Fit the power supply wiring of each unit with a switch and fuse as shown in the drawing below.

Complete system example

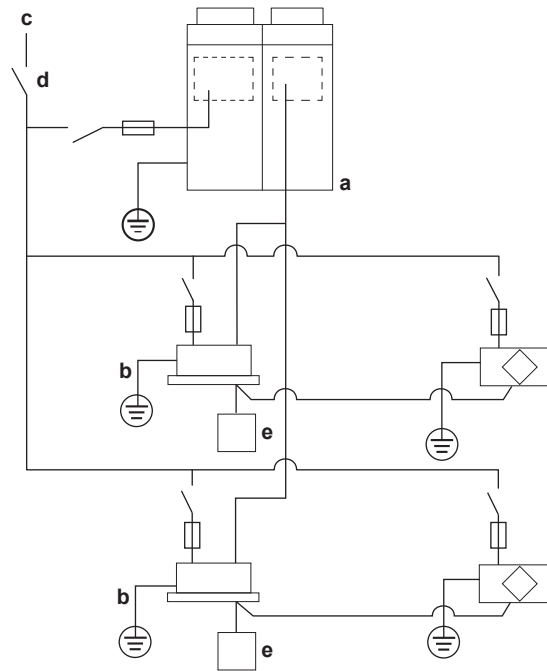

- a** VRV outdoor unit
- b** VRV indoor unit
- c** Power supply
- d** Main switch
- e** Controller

15.1.4 Component electrical specifications

Model	350	500	650	800	1000	1500	2000
Power supply							
Voltage	220~240 V ± 10%.						
Frequency	50/60 Hz						
MCA (A)	1.56	2.08	2.80	4.39	4.90	8.78	9.80
MFA (A)	6	6	6	6	6	16	16
Fan motor							
P (kW)	0.08×2	0.08×2	0.11×2	0.21×2	0.21×2	0.21×4	0.21×4
FLA (A)	0.62×2	0.83×2	1.12×2	1.76×2	1.96×2	1.76×4	1.96×4

- MCA** Minimum Circuit Amps
- MFA** Maximum Fuse Amps
- P** Motor Rated Load
- FLA** Full Load Amps



NOTICE

The power supply **MUST** be protected with the required safety devices, i.e. a main switch, a slow blow fuse on each phase and an earth leakage protector in accordance with the applicable legislation.



NOTICE

In the power supply line, **ALWAYS** install a residual current device (RCD) with an instantaneous action. The installed RCD **MUST** comply with the national wiring regulation.

**NOTICE**

See the data book for more details.

15.1.5 Specifications for field supplied fuses and wires

Power supply wiring	
Field supplied fuses	6 A/16 A
Wire	H05VV-U3G
Size	Wire size MUST comply with the applicable legislation.
Interconnection wiring	
Wiring	Sheathed wire (2 wire)
Size	0.75~1.25 mm ²

Precautions

When connecting more than one wire to the power supply wiring, use a 2 mm² (Ø1.6 mm) gauge wire.

When using 2 power wires of a gauge greater than 2 mm² (Ø1.6 mm), branch the line outside the terminal board of the unit, in accordance with electrical equipment standards. The branch MUST be sheathed to provide a degree of insulation equal to or greater than the power supply wiring itself.

Limit the total current of crossover wiring between indoor units to less than 12 A.

Do NOT connect wires of different gauge to the same grounding terminal. Loose connections may reduce the protection.

For the controller wiring, refer to the installation manual of the controller delivered with the controller.

Wiring example

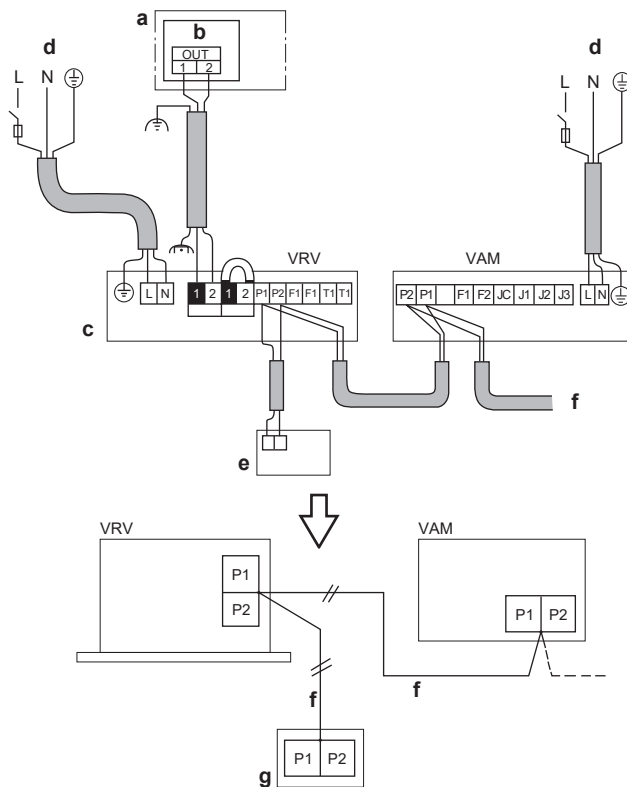

- a Outdoor unit/BS unit
- b Switch box
- c Indoor unit
- d Power supply 220-240 V~50/60 Hz
- e Controller for VRV
- f Interconnection wiring
- g Controller for VAM
- VRV** VRV indoor unit
- VAM** VAM heat reclaim ventilation unit



WARNING

The VAM and the EKVDX indoor unit **MUST** share the same electrical safety devices and power supply.

15.2 Opening the switch box



CAUTION

Before opening the cover, be sure to turn off the power switches of the main units and other devices connected to the main units.

- Remove the screws that secure the cover and open the switch box.
- Secure the power supply cable and the control wire with a tie wrap, as shown in the figures.

Models 350~650

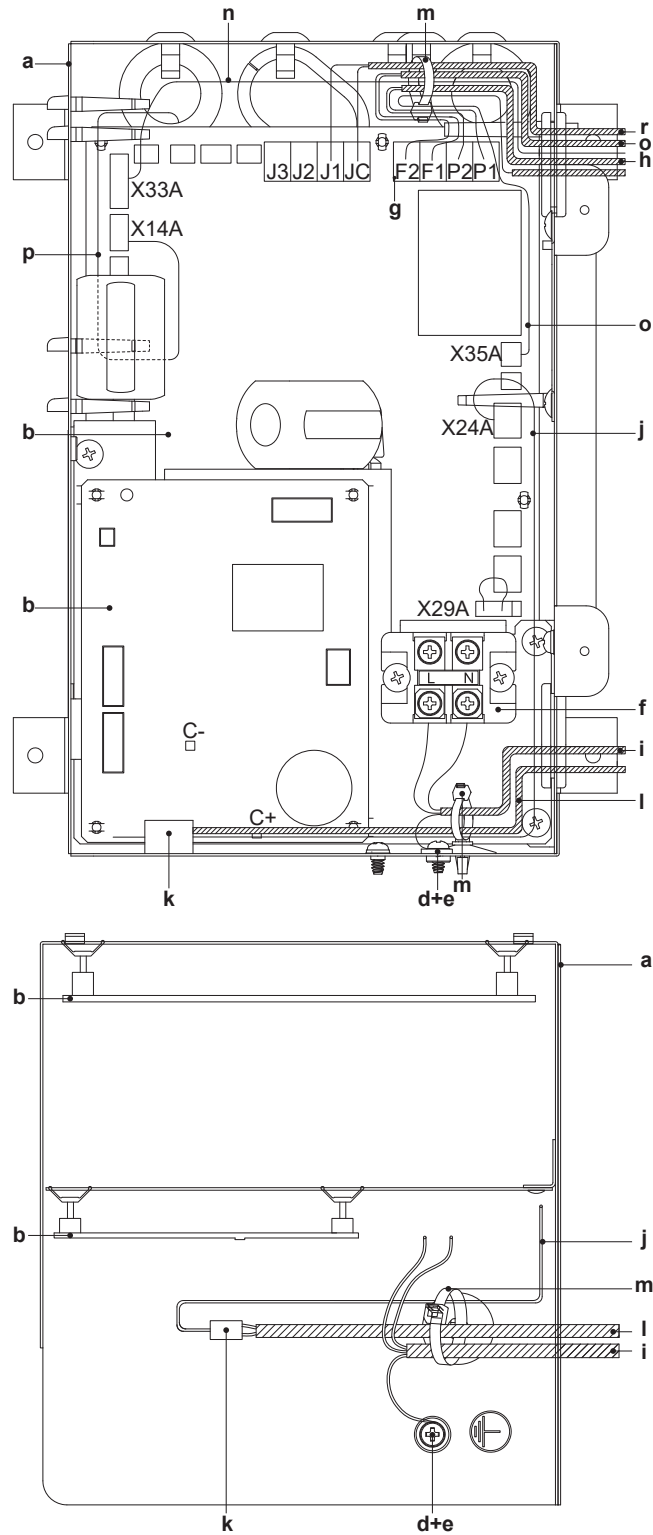

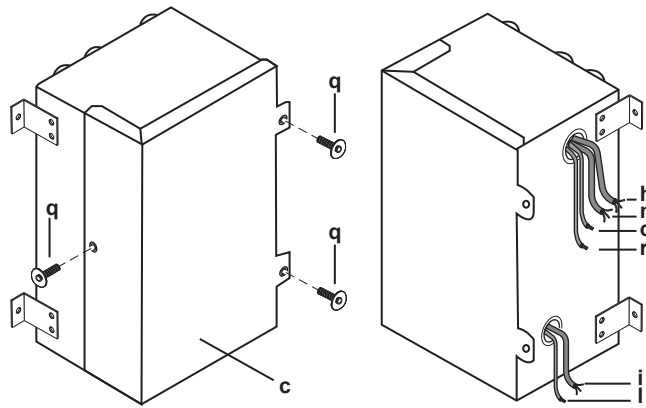

- a** Switch box
- b** PCB
- c** Switch box cover
- d** Securing screw and washer
- e** Grounding terminal
- f** Terminal board
- g** Interconnection wiring terminal board (P1, P2, F1, F2)
- h** Interconnection wiring (to optional controller)
- i** Power supply cable
- j** Wires for connection of additional external damper (supplied accessory)
- k** Insulated splices-closed barrel connector (0.75 mm²) (field supply)
- l** Double or reinforced insulated flexible cable (0.75 mm²) to external damper (field supply)
- m** Tie wrap (field supply)
- n** BRP4A50A (optional accessory)
- o** KRP2A51 (optional accessory)
- p** CO₂ sensor (optional accessory)
- q** Tapping screw
- r** Wires for fresh-up operation

Models 800+1000

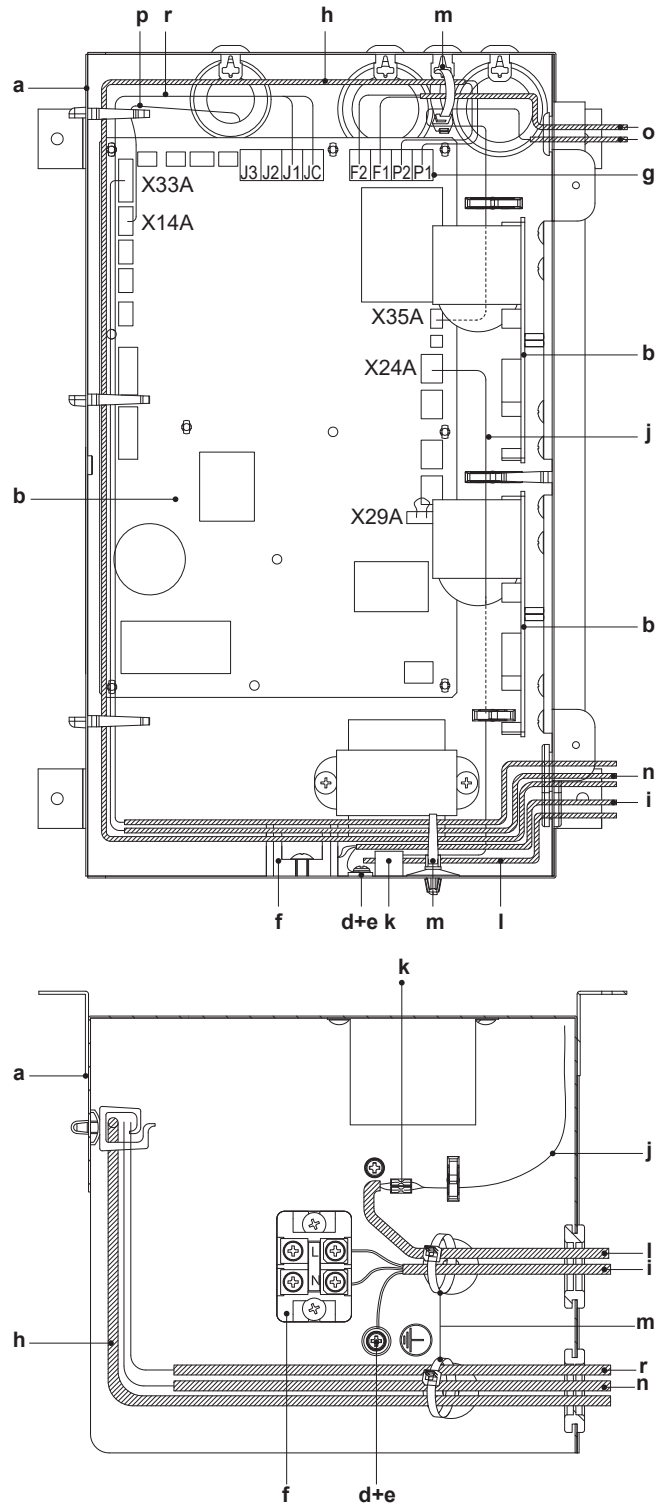

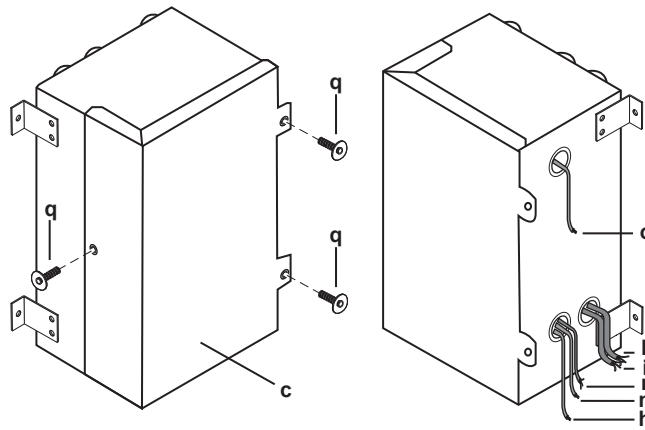

- a** Switch box
- b** PCB
- c** Switch box cover
- d** Securing screw and washer
- e** Grounding terminal
- f** Terminal board
- g** Interconnection wiring terminal board (P1, P2, F1, F2)
- h** Interconnection wiring (to optional controller)
- i** Power supply cable
- j** Wires for connection of additional external damper (supplied accessory)
- k** Insulated splices-closed barrel connector (0.75 mm²) (field supply)
- l** Double or reinforced insulated flexible cable (0.75 mm²) to external damper (field supply)
- m** Tie wrap (field supply)
- n** BRP4A50A (optional accessory)
- o** KRP2A51 (optional accessory)
- p** CO₂ sensor (optional accessory)
- q** Tapping screw
- r** Wires for fresh-up operation

Models 1500+2000

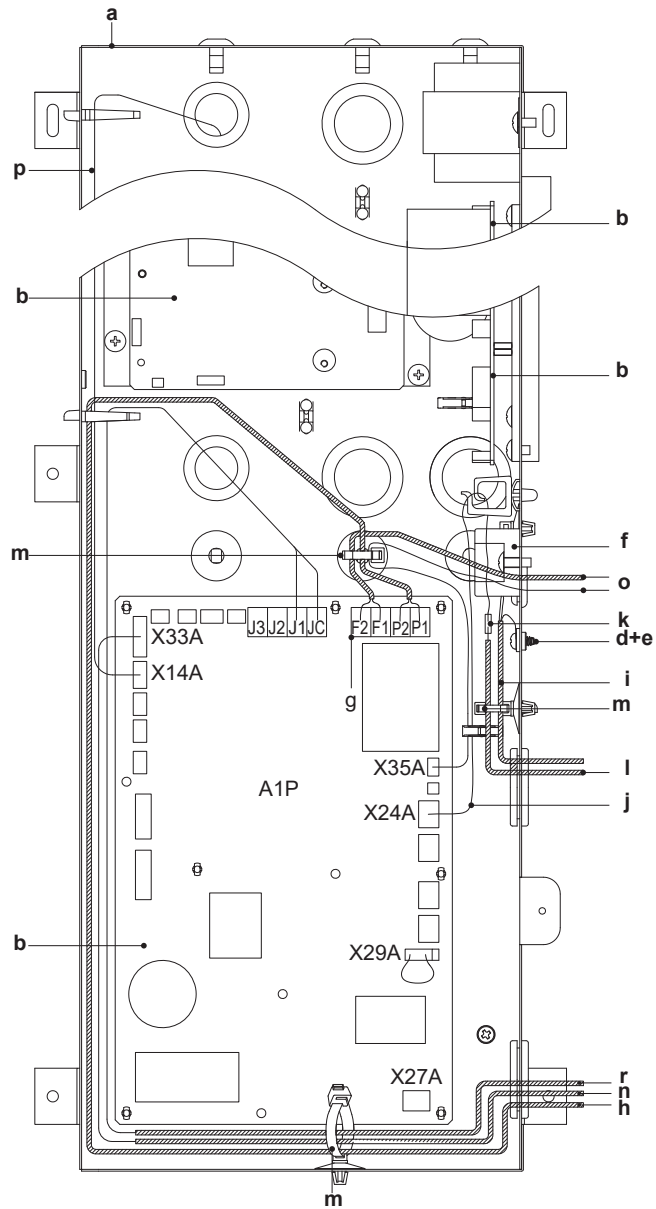

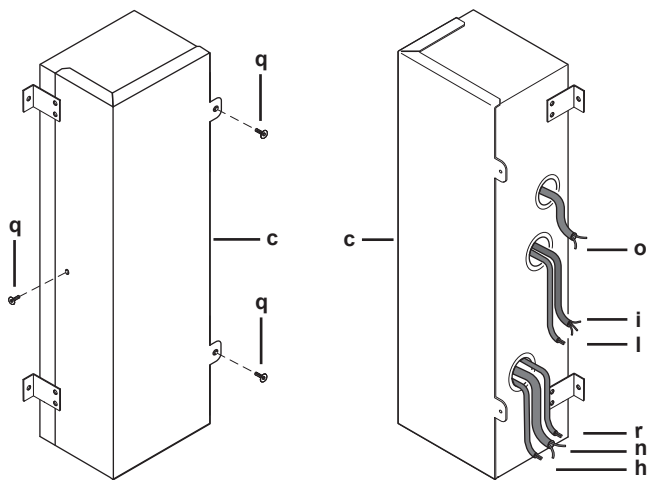
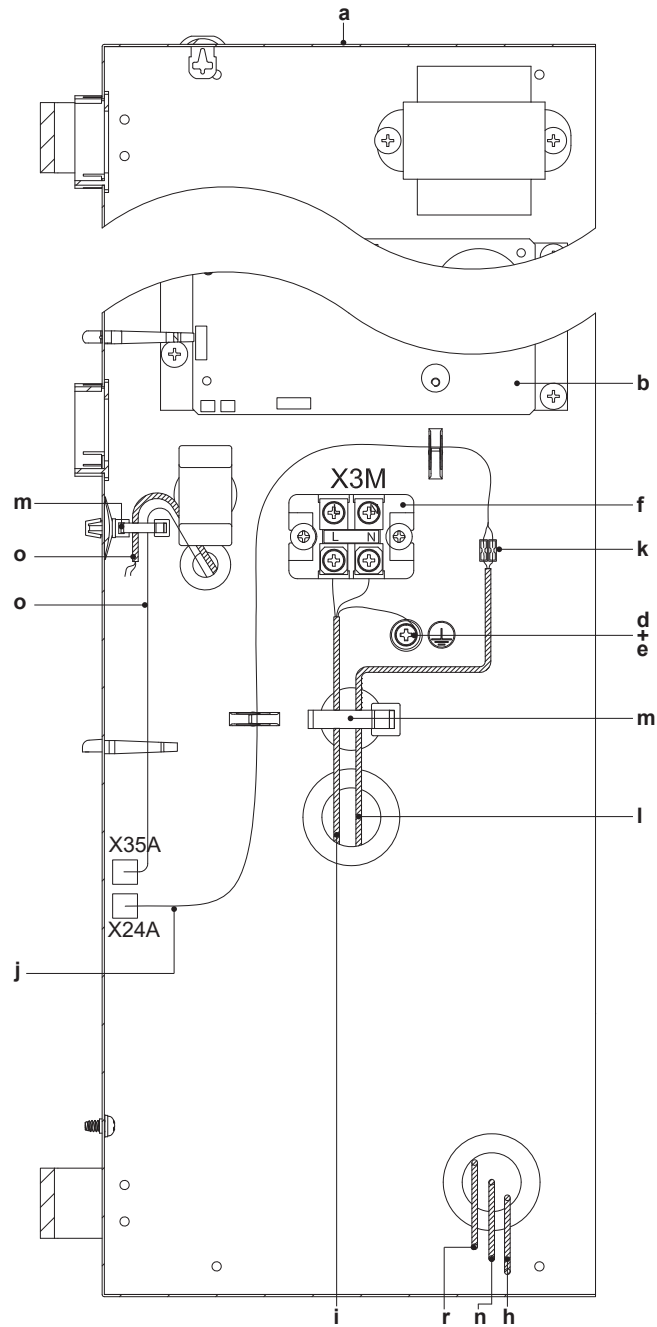

- a Switch box
- b PCB
- c Switch box cover

- d** Securing screw and washer
- e** Grounding terminal
- f** Terminal board
- g** Interconnection wiring terminal board (P1, P2, F1, F2)
- h** Interconnection wiring (to optional controller)
- li** Power supply cable
- j** Wires for connection of additional external damper (supplied accessory)
- k** Insulated splices-closed barrel connector (0.75 mm²) (field supply)
- l** Double or reinforced insulated flexible cable (0.75 mm²) to external damper (field supply)
- m** Tie wrap (field supply)
- n** BRP4A50A (optional accessory)
- o** KRP2A51 (optional accessory)
- p** CO₂ sensor (optional accessory)
- q** Tapping screw
- r** Wires for fresh-up operation

15.3 Electrical connections for additional field supplied damper

An external damper prevents the intake of outdoor air when the VAM is switched off.

The VAM main PCB provides a contact for an external damper.

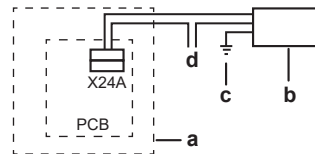

- a** VAM
- b** External damper
- c** External damper earthing
- d** Power source



CAUTION

Follow the instructions below carefully.

Required electrical connections

Connect one end of the accessory wire to the X24A connector on the PCB and the other end to the wire leading to the external damper via an insulated splices-closed barrel connector (0.75 mm²).

The electrical circuit requires a current protection of 3 A and a maximum voltage of 250 V.

X24A will close the contact when the VAM fan starts operating and it will open the contact when the fan is stopped.

15.4 To connect the electrical wiring



WARNING

Do NOT extend the power supply or the interconnection cable by using wire connectors, wire connection clamps, taped wires, extension cords. These can cause overheating, electric shock or fire.



WARNING

The VAM and the EKVDX indoor unit MUST share the same electrical safety devices and power supply.

**NOTICE**

Factory settings: Do NOT change the switch settings when a controller is connected. SS1 is a setting switch to operate the unit without controller. Changing the switch setting when a controller is connected will stop the unit from operating normally. Keep the switch on the PCB in the factory setting position.

15.5 To connect the monitoring output

Prerequisite: Connect the adapter PCB BRP4A50A to monitor operation.

- 1 Plug the connector of the adapter PCB BRP4A50A into the X33A port.

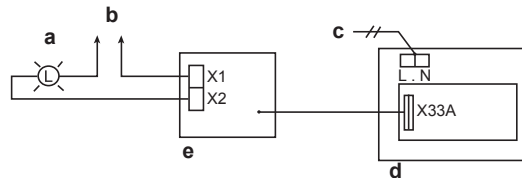

- a Operation lamp
- b Power source
- c Power source
- d Heat reclaim ventilation unit's PCB
- e Adapter PCB (BRP4A50A)

If X1 and X2 are connected like in the figure, then, depending on setting 18(28)-9, a signal is output when the unit is ON and/or when it is in 24-hour ventilation.

If X3 and X4 are also connected to BRP4A50A, then, depending on setting 18(28)-9, a second signal can be output about fan operation or when the unit is in error. If a heater is connected, the signal is output to the heater.

16 System configuration

Table of Contents

16.1	About control systems.....	64
16.2	Independent system.....	65
16.3	Linked operation control system.....	65
16.4	Central control system.....	66
16.5	EKVDX option.....	67

16.1 About control systems

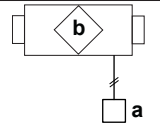
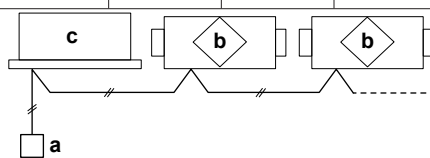
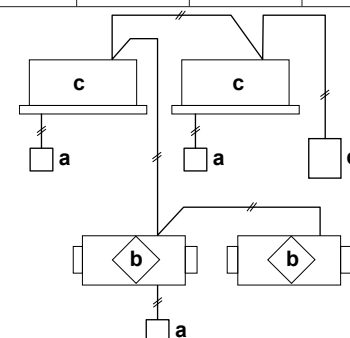
Independent system control system	Central controller	Unified ON/OFF controller	Schedule timer	Controller for VAM	Controller for air conditioner	Operation/stop
Basic method to operate the VAM unit. Available functions in case of an independent system control system: <ul style="list-style-type: none"> Ventilation mode changeover: automatic or manual Air flow rate changeover: high/low Air flow rate mode changeover: normal mode/fresh-up mode: initial setting required Malfunction display 	—	—	—	•	•	•
						
Linked operation control system	Central controller	Unified ON/OFF controller	Schedule timer	Controller for VAM	Controller for air conditioner	Operation/stop
<ul style="list-style-type: none"> Linked operation with air conditioner by controller for air conditioner. Maximum 16 units. The VAM unit can also be operated independently by the controller for the air conditioner, even if the air conditioner is NOT in operation. The VAM unit CANNOT be operated independently when the duct is connected directly to the air conditioner. Available functions in case of a linked operation control system: <ul style="list-style-type: none"> Ventilation mode changeover: automatic or manual Air flow rate changeover: high/low Air flow rate mode changeover: normal mode/fresh-up mode: initial setting required Precool/preheat operation: initial setting required Nighttime free cooling operation: initial setting required Malfunction display For an overview of settings, see "17.2 Field settings" [73].	—	—	—	—	•	•
						
Central control system	Central controller	Unified ON/OFF controller	Schedule timer	Controller for VAM	Controller for air conditioner	Operation/stop
<ul style="list-style-type: none"> Unified ON/OFF controller: Maximum 16 groups of units. Schedule timer: 1 schedule timer can control the weekly schedule of 128 units. Central controller: Up to 64 groups of units can be controlled individually by 1 central controller. Available functions in case of a central control system: <ul style="list-style-type: none"> Ventilation mode changeover: automatic or manual Air flow rate changeover: high/low Air flow rate mode changeover: normal mode/fresh-up mode (field setting required when controller for heat reclaim ventilation unit is NOT used) Air flow rate mode changeover: normal mode/fresh-up mode (when controller for VAM unit is installed) Precool/preheat operation: initial setting required Nighttime free cooling operation: initial setting required Malfunction display For an overview of settings, see "17.2 Field settings" [73].	•	•	•	•	•	•
						

- a Controller
- b Heat reclaim ventilation unit (VAM)
- c Air conditioner
- d Unified ON/OFF controller, Schedule timer, Central controller

16.2 Independent system

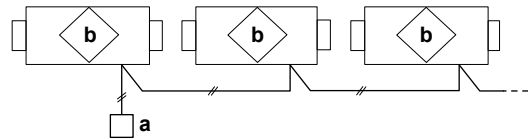

- a** Controller
- b** Heat reclaim ventilation unit (VAM)

- Up to 16 units can be controlled with the controller (a system with 2 controllers can be created using master/slave switching).
- All VAM operations can be used and displayed.
- The controller cord should be procured locally (cord length: up to 500 m).

For configuration, see "[17.3.2 Independent system](#)" [▶ 76]

16.3 Linked operation control system

Combined operation system with VRV systems and Sky Air series

1-group linked operation control system

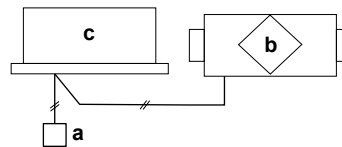

- a** Controller
- b** Heat reclaim ventilation unit (VAM)
- c** Air conditioner

- A total of up to 16 air conditioners and VAM units can be controlled.
- The ventilation mode can be operated independently when air conditioners are NOT used.
- Using the local setting of the controller for air conditioners, various settings such as precool/preheat on/off, ventilation flow rate, ventilation mode, etc. can be selected.

For configuration, see "[17.3.3 1-group linked-control system](#)" [▶ 77].

Multi-group linked operation control system

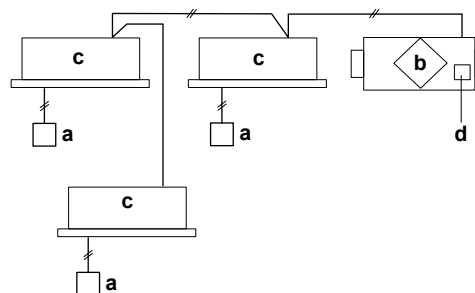

- a** Controller
- b** Heat reclaim ventilation unit (VAM)
- c** Air conditioner
- d** Adapter PCB for remote control

- Since all VRV units of the installation are connected to a single communication line, they will all be operated.
- If there are problems operating all VRV units, do NOT use this system.
- Up to 64 groups of units can be controlled.

- The controller control transmission line can be extended to up to 1000 m.
- A direct duct connection is NOT possible.
- Set ON for central zone link setting.
- Adapter PCB for remote control: KRP2A51 (One adapter PCB should be installed in either the VAM or the air conditioner).

For configuration, see "[17.3.4 Linked control with more than 2 groups](#)" [▶ 77].

Direct duct connection system

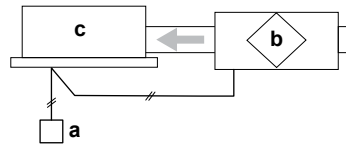

- a** Controller
- b** Heat reclaim ventilation unit (VAM)
- c** Air conditioner

- The VAM will operate ONLY when the air conditioner fan is on.
- Other specifications are the same as those of the standard system.

For configuration, see "[17.3.5 Direct duct connection](#)" [▶ 78].

16.4 Central control system

All/individual control system

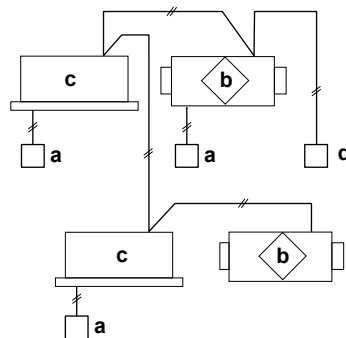

- a** Controller
- b** Heat reclaim ventilation unit (VAM)
- c** Air conditioner
- d** Central controller

- Unified ON/OFF controller: DCS301B(A)51. Up to 16 groups can be controlled (ON/OFF) by 1 controller and up to 4 controllers can be installed in 1 system.
- Schedule timer: DST301B(A)51. One schedule timer can control the weekly schedule of up to 128 units.
- Adapter PCB for remote control: KRP2A51 (NOT possible to use together with another central controller). 1 adapter PCB can control up to 64 groups collectively.
- One of the controllers must be connected to an air conditioner. However, ONLY KRP2A51 can be connected to a VAM.

For configuration, see "[17.3.6 Central control system](#)" [▶ 79].

Zone control system

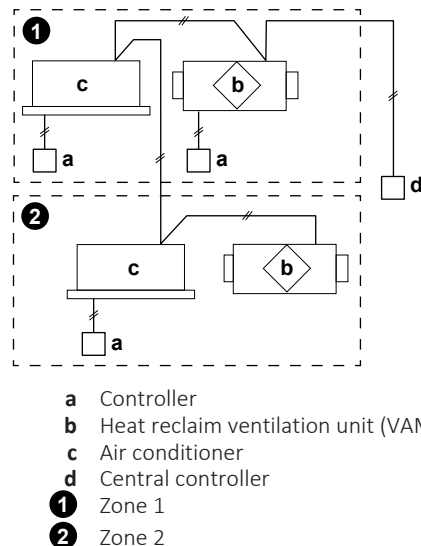

- Use of the central controller enables zone control via the central control line (up to 64 zones).
 - Central controller DCS302C(A)51, intelligent Touch Controller DCS601C51, or intelligent Touch Manager DCM601A51.
 - A central controller can control independent operation of the VAM in each zone.
- For configuration, see "[17.3.6 Central control system](#)" [▶ 79].

16.5 EKVDX option

VAM and EKVDX combinations have the following restrictions:

- One remote controller per VAM and EKVDX combination.
- NO group control.
- NO slave remote controllers.
- NO linkage to indoor(s) other than the one towards EKVDX.
- NO direct duct to indoor(s) other than the one towards EKVDX.
- NO supervising remote control connected on EKVDX. It has to be installed on normal VRV indoor.

See the EKVDX installer and user reference guide for more information.

Independent system with EKVDX

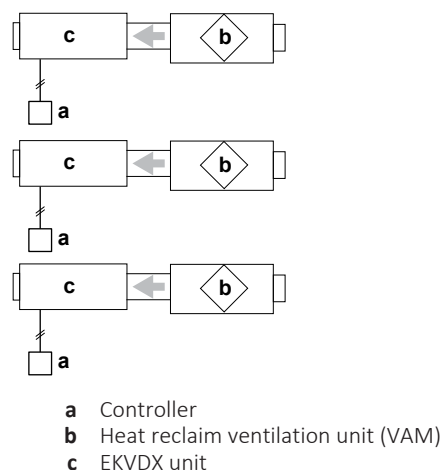

Central control system with EKVDX

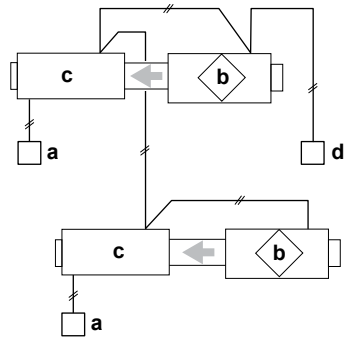

- a** Controller
- b** Heat reclaim ventilation unit (VAM)
- c** EKVDX unit
- d** Central controller

17 Configuration

In this chapter

17.1	To change settings.....	69
	Case 1: Change settings with BRC1E53	70
	Case 2: Change settings with BRC301B61	71
	Case 3: Change settings with BRC1H	71
	Case 4: Change settings with BRC1K	72
17.2	Field settings.....	73
17.3	Settings for all configurations.....	75
17.3.1	About settings 19(29)-0-04 and 19(29)-0-05	76
17.3.2	Independent system	76
17.3.3	1-group linked-control system.....	77
17.3.4	Linked control with more than 2 groups.....	77
17.3.5	Direct duct connection	78
17.3.6	Central control system.....	79
17.3.7	EKVDX option - extra settings	82
17.4	About the controller	83
17.4.1	BRC1E53 controller	83
17.4.2	BRC301B61 controller.....	86
17.4.3	BRC1H controller.....	88
17.4.4	BRC1K controller	88
17.5	Detailed explanation of settings.....	89
17.5.1	About fresh-up operation	89
17.5.2	About the external damper operation	90
17.5.3	About the CO ₂ sensor.....	91
17.5.4	About nighttime free cooling operation.....	95
17.5.5	About the precool and preheat function.....	96
17.5.6	About preventing a feeling of draft	96
17.5.7	About 24-hour ventilation	96
17.5.8	About the ultra-low setting.....	96
17.5.9	About the electrical heater operation.....	97
17.5.10	About external linkage input	97
17.5.11	About filter contamination check.....	97

17.1 To change settings

The heat reclaim ventilation unit settings can be adjusted using the controller of either the heat reclaim ventilation unit or the air conditioner.

The settings (format: e.g. **19(29)-1-02**), that are used in this chapter are composed of 3 parts, divided by "-":

- Mode number: e.g. **19(29)**, where **19** is the mode number for group settings and **29** is the mode number for individual settings.
- Switch number: e.g. **1**
- Position number: e.g. **02**

Initial settings

- Mode numbers **17**, **18**, and **19**: group control of heat reclaim ventilation units.



NOTICE

Field setting mode numbers **17**, **18** and **19** CANNOT be used with EKVDX indoor units.

- Mode numbers **27**, **28**, and **29**: individual control or when operating with the optional EKVDX units.

Case 1: Change settings with BRC1E53

Make sure that the switch box lid on the heat reclaim ventilation unit is closed.

- 1 Briefly press a button to turn on the screen light.
- 2 Press and hold the Cancel button (a) for at least 4 seconds to enter the Service Settings menu.
- 3 Go to Field Settings with the Up/Down buttons and press the Menu/Enter button (b).
- 4 Press the Left/Right buttons to highlight the number under Mode.
- 5 Press the Up/Down buttons to select the required mode number.

Result: From mode **20** and up, you also have to select a unit number for individual control.

- 6 Use the Left/Right buttons to highlight the number under Unit No..
- 7 Use the Up/Down buttons to select an indoor unit number. Selecting a unit number is NOT necessary when configuring the entire group.
- 8 Use the Left/Right buttons to select a switch number (0 to 15) to change.

In case of individual settings:

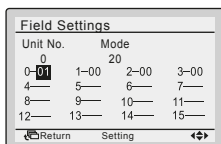

In case of group settings:

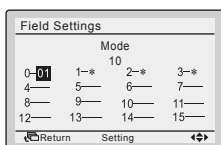

- 9 Use the Up/Down buttons to select the required position number.
- 10 Press the Menu/Enter (b) button and confirm the selection with Yes.

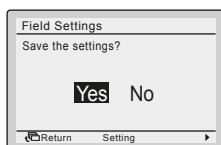

- 11 After you have completed all changes, press the Cancel button (a) twice to return to the normal mode.

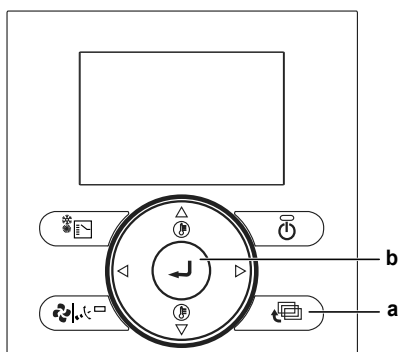

- a Cancel button
- b Menu/Enter button

Case 2: Change settings with BRC301B61

Make sure that the switch box lid on the heat reclaim ventilation unit is closed.

- 1 With the unit in normal mode, press the Inspection/Trial button (a) for more than 4 seconds to enter the local setting mode.
- 2 Use the Ventilation mode button (b) and the Airflow rate button (c) to select a mode number.

Result: The code display is blinking.

- 3 To configure settings for individual units under group control, press the Timer setting on/off button (d) and select the number of the unit that you want to configure.
- 4 To select the setting switch number, press the top section of the Timer button (e). To select the setting position number, press the lower section of the Timer button (e).
- 5 Press the Program/Cancel button (f) once to enter the setting.

Result: The code display stops blinking and lights up.

- 6 Press the Inspection/Trial button (a) to return to normal mode.

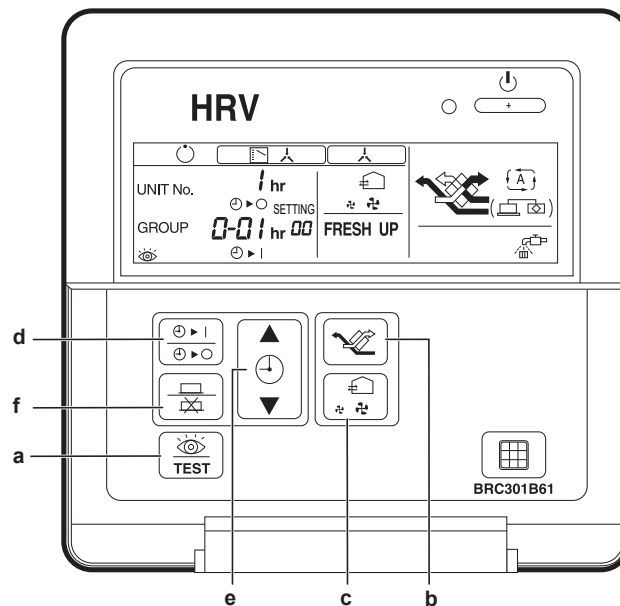

- a Inspection/Trial button
- b Ventilation mode button
- c Airflow rate button
- d Timer setting on/off button
- e Timer button
- f Program/Cancel button



INFORMATION

Setting 18(28)-11 CANNOT be selected with this controller.

Case 3: Change settings with BRC1H



INFORMATION

Please refer to the Installer and user reference guide of the BRC1H remote controller.

Case 4: Change settings with BRC1K



INFORMATION

Please refer to the installer and user reference guide of the BRC1K remote controller.

17.2 Field settings

Mode	SW	SW description	SW position ^(a)														
			01	02	03	04	05	06	07	08	09	10	11	12	13	14	15
17 (27)	0	Filter cleaning time	±2500 hours	±1250 hours	—	—	—	—	—	—	—	—	—	—	—	—	—
	1	Nighttime free cooling timer (after stop) ^(b)	OFF	ON after 2 hours	ON after 4 hours	ON after 6 hours	ON after 8 hours	—	—	—	—	—	—	—	—	—	—
	2	Precool/preheat ^(c)	OFF	ON	—	—	—	—	—	—	—	—	—	—	—	—	—
	3	Precool/preheat duration ^(c)	30 minutes	45 minutes	60 minutes	—	—	—	—	—	—	—	—	—	—	—	—
17 (27)	4	Initial fan speed ^(d)	High	Ultra-high	—	—	—	—	—	—	—	—	—	—	—	—	—
	5 ^(e)	Yes/No setting for duct connection with VRV system	Without duct	With duct	Without duct	Without duct	With duct	Without duct	With duct	Without duct	Without duct	Without duct	Without duct	Without duct	Without duct	Without duct	Without duct
		Fan setting for cold areas ^(f)	—	—	Stop/Stop	Low/Low	Stop/stop	Low/Low	Stop/stop	Low/Low	—	—	—	—	—	—	—
		Fan operation during defrost/oil return/hot start ^(f)	—	—	Stop/Stop	Stop/Stop	Stop/Stop	Stop/Stop	Stop/Stop	Stop/Stop	Stop/Stop	Stop/Stop	Stop/Stop	Stop/Stop	Stop/Stop	Stop/Stop	Stop/Stop
17 (27)	6	Nighttime free cooling (fan settings) ^(b)	High	Ultra-high	—	—	—	—	—	—	—	—	—	—	—	—	—
	7	Target temperature for independent nighttime free cooling ^(b)	18°C	19°C	20°C	21°C	22°C	23°C	24°C	25°C	26°C	27°C	28°C	29°C	30°C	—	—
	8	Central zone link	No	Yes	—	—	—	—	—	—	—	—	—	—	—	—	—
	9	Preheat time extension ^(c)	0 minutes	30 minutes	60 minutes	90 minutes	—	—	—	—	—	—	—	—	—	—	—
18 (28)	0	External signal ^(g) /JC/12	Last command	Priority on external input	Priority on operation	Disable nighttime free cooling/ Perform forced stop	24 hours ventilation ON/OFF	—	—	—	—	—	—	—	—	—	—
	1	Direct power ON	OFF	ON	—	—	—	—	—	—	—	—	—	—	—	—	—
	2	Auto restart ^(h)	OFF	ON	—	—	—	—	—	—	—	—	—	—	—	—	—
	3	Output signal to external damper (X24A)	—	—	Damper output (fan operation)	Damper output (fan operation)	—	—	—	—	—	—	—	—	—	—	—
18 (28)	4	Indication of ventilation mode	ON	OFF	—	—	—	—	—	—	—	—	—	—	—	—	—
	6	Automatic ventilation air flow mode	Linear	Exhaust – no indication	Fixed A	Fixed B	Exhaust – indication	—	—	—	—	—	—	—	—	—	—
	7	Fresh-up mode	Supply – no indication	Exhaust – no indication	Supply – indication	Exhaust – indication	—	—	—	—	—	—	—	—	—	—	—
	8	External input terminal function selection ⁽ⁱ⁾ (JC/J1)	Fresh-up	Error output	Error output and stop operation	Forced off	Fan forced off	Air-flow up	—	—	—	—	—	—	—	—	—
18 (28)	9	BRP4A50A output switching selection (between X3 and X4)	Heater output	Error output	Fan output (Low/High/ Ultra-high)	Fan output (High/ Ultra-high)	Fan output (Ultra-high)	Fan output (Low/High/ Ultra-high)	—	—	—	—	—	—	—	—	—
		(between X1 and X2)	Operation output	Operation output	Operation output	Operation output	Operation output	Operation output	Operation output	Operation output	Operation output	Operation output	Operation output	Operation output	Operation output	Operation output	Operation output
	10	EKVDX connected? ^(j)	No	Yes	—	—	—	—	—	—	—	—	—	—	—	—	—
	11	Filter contamination check	No action	Reset filter check	Force filter check	—	—	—	—	—	—	—	—	—	—	—	—
18 (28)	13	Cooling set point (with EKVDX)	13°C	15°C	16°C	17°C	18°C	19°C	20°C	21°C	22°C	23°C	24°C	25°C	26°C	28°C	30°C
	14	Heating set point (with EKVDX)	24°C	26°C	27°C	28°C	29°C	30°C	31°C	32°C	33°C	35°C	37°C	39°C	41°C	43°C	45°C

Mode	SW	SW description	SW position ^(a)														
			01	02	03	04	05	06	07	08	09	10	11	12	13	14	15
19 (29)	0	Filter contamination inspection ^(k)	Pressure-based check with fan step 1-15	Pressure-based check with new fan step	Timer based check	Filter contamination target detection with fan step 1-15	Auto ESP selection and filter contamination target detection with new fan step	—	—	—	—	—	—	—	—	—	—
	1	Low tap ^(l)	OFF	Run 1/15 (28 min. OFF/2 min. ON)	Run 1/10 (27 min. OFF/3 min. ON)	Run 1/6 (25 min. OFF/5 min. ON)	Run 1/4 (22.5 min. OFF/7.5 min. ON)	Run 1/3 (20 min. OFF/10 min. ON)	Run 1/2 (15 min. OFF/15 min. ON)	Step 1	Step 2	Step 3	Step 4	Step 5	Step 6	Step 7	
	2	Supply fan step ^(m)	Step 1	Step 2	Step 3	Step 4	Step 5	Step 6	Step 7	Step 8	Step 9	Step 10	Step 11	Step 12	Step 13	Step 14	Step 15
19 (29)	3	Exhaust fan step ^(m)	Step 1	Step 2	Step 3	Step 4	Step 5	Step 6	Step 7	Step 8	Step 9	Step 10	Step 11	Step 12	Step 13	Step 14	Step 15
	4	24-hour ventilation ^(l)	OFF	Run 1/15 (28 min. OFF/2 min. ON)	Run 1/10 (27 min. OFF/3 min. ON)	Run 1/6 (25 min. OFF/5 min. ON)	Run 1/4 (22.5 min. OFF/7.5 min. ON)	Run 1/3 (20 min. OFF/10 min. ON)	Run 1/2 (15 min. OFF/15 min. ON)	Step 1	Step 2	Step 3	Step 4	Step 5	Step 6	Step 7	Step 8
	5	Humidification ON/OFF setting	ON	OFF	—	—	—	—	—	—	—	—	—	—	—	—	—
1A	7	Reference concentration shift for ventilation air flow control (ppm)	0	+200	+400	+600	-200	-400	-600	—	—	—	—	—	—	—	—
	8	Stop ventilation by automatic ventilation air flow control	Allowed	NOT allowed	Allowed	NOT allowed	—	—	—	—	—	—	—	—	—	—	—
	8	Fan residual operation	OFF	OFF	Heater operation	Heater operation	—	—	—	—	—	—	—	—	—	—	—
1A	9	Normal ventilation tap on automatic ventilation air flow control	—	—	—	—	Control by CO ₂ sensor	—	—	—	—	—	—	—	—	—	—
	15	R32 safety system ⁽ⁿ⁾	OFF	ON	—	—	—	—	—	—	—	—	—	—	—	—	—
	0	Fresh-up operation ^(k)	OFF	ON	—	—	—	—	—	—	—	—	—	—	—	—	—

(a) Factory settings are marked with a grey background.
 (b) In case VAM and EKVDX are combined and the R32 safety system of the VAM is active, the nighttime free cooling is disabled.
 (c) The preheating/precooling function of the heat reclaim ventilation unit is disabled when it is connected to an EKVDX.
 (d) When connected to an EKVDX, set to 2 or 4.
 (e) When connected to an EKVDX, 17(27) - 5 can be set to 1, 3, 4, 7 or 8.
 (f) Fan operation when heater thermostat is OFF. Supply air/Exhaust air, e.g. Low/Low means: Supply air low/Exhaust air low.
 (g) When connected to an EKVDX, J1/J2 cannot be used. Set to 18(28) - 0-7. Instead, use T1 T2 of the EKVDX. See the EKVDX Installation and operation manual.
 (h) When connected to an EKVDX, do not change the default settings.
 (i) When connected to an EKVDX, J1/J1 cannot be used.
 (j) When connected to an EKVDX, set to 18(28) - 10-2.
 (k) When connected to an EKVDX, a filter contamination check is performed automatically and is timer based. This setting CANNOT be done with BRC301B61.
 (l) When connected to an EKVDX, this field setting will always be OFF.
 (m) See the technical data book for pressure drop curves and selection of fan curves (step 1 to 15).
 (n) When connected to an EKVDX, setting 2 (safety ON) is required in case R32 refrigerant is used. Setting 1 (safety OFF) is required in case R410A refrigerant is used.

Note: When connected to an EKVDX, SS1 cannot be used. Instead, use T1 T2 of the EKVDX. See the EKVDX Installation and operation manual.
Note: The setting modes are mentioned as group settings, between parentheses are the setting modes for individual unit control or when connected to the EKVDX option. Group number setting for central controller: mode 00=group controller / mode 30=individual controller. For the setting procedure, see "Group number setting for central control" in the operation manual of either the ON/OFF controller or the central controller.

17.3 Settings for all configurations

Setting 17(27)-4: First choose the fan speed. Set it to high or ultra-high.

Flow "All other system configurations" is not applicable when combining VAM with EKVDX. Check the field settings for both units to make sure the combination of VAM and EKVDX is operational

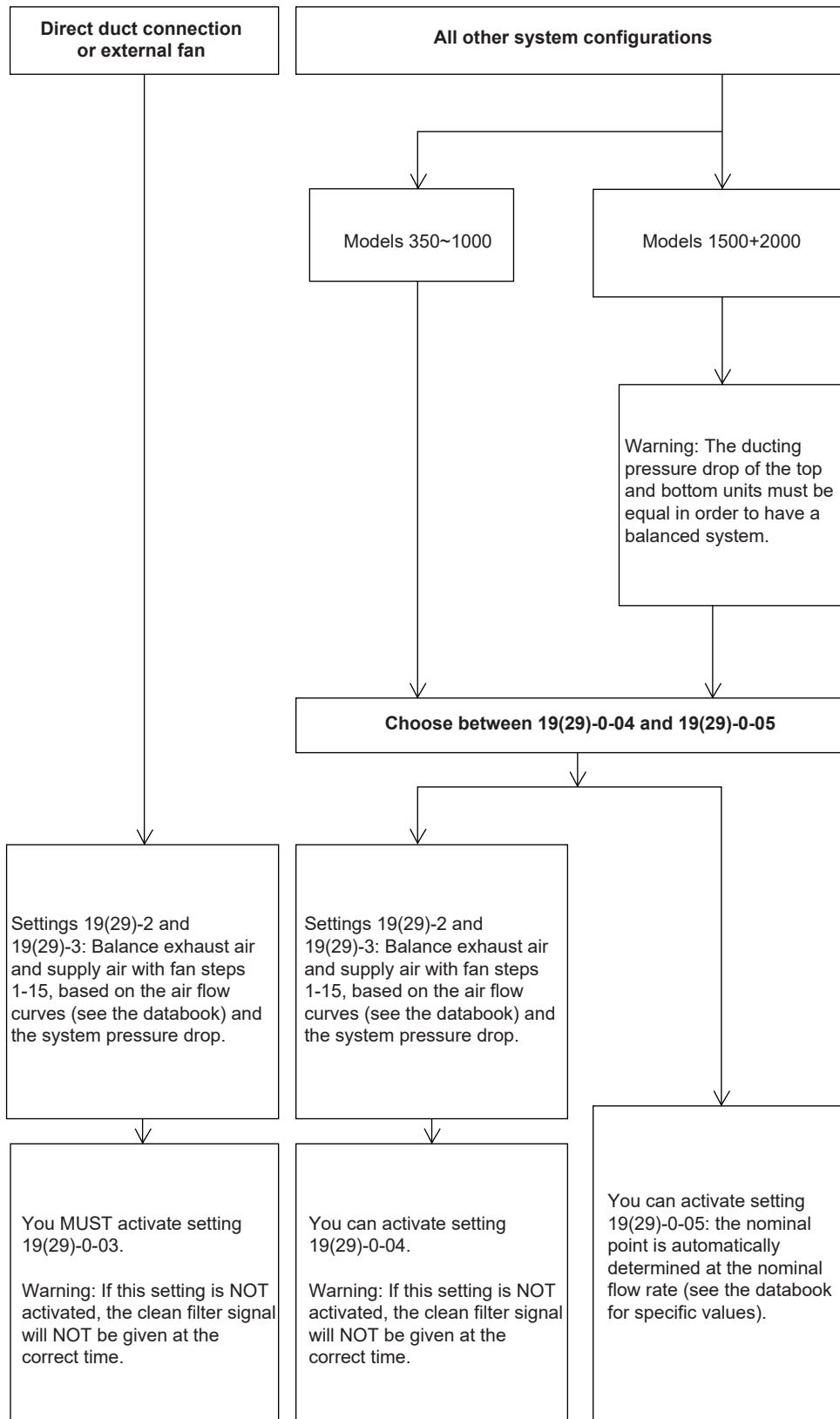

17.3.1 About settings **19(29)-0-04** and **19(29)-0-05**

- When you have configured setting **19(29)-0-04** successfully, the system automatically changes it to setting **19(29)-0-01**.
- When you have configured setting **19(29)-0-05** successfully, the system automatically changes it to setting **19(29)-0-02**.



NOTICE

If the ducting is changed, install clean filters and reconfigure setting **19(29)-0-04** or **19(29)-0-05**. Otherwise the signal to clean the filters will come too soon. Do NOT adjust the dampers when setting **19(29)-0-04** or **05** is activated.

- If the controller is switched off while activating setting **19(29)-0-04** or **19(29)-0-05**, configuration is aborted. When you switch the controller back on, the function starts from the beginning.
- Setting **19(29)-0-04** takes between 1 and 6 minutes to complete. You can check if the setting was completed successfully by checking if the field setting is changed to **0-01**.
- Setting **19(29)-0-05** takes between 3 and 35 minutes to complete. You can check if the setting was completed successfully by checking if the field setting is changed to **0-02**.



INFORMATION

While activating setting **19(29)-0-04** and **19(29)-0-05**, the unit is set to heat recovery and the fan is on high or ultra high. After configuration, the settings are returned to what they were before the configuration.

- These settings can ONLY be activated with clean filters.
- For models 1500+2000, make sure that the ducting pressure drop of the top and bottom units is balanced.
- The function starts as soon as it is selected and the controller is on.
- Setting **19(29)-0-04** CANNOT be configured if the outside temperature is $\leq -10^{\circ}\text{C}$, which is out of the operation range.
- Setting **19(29)-0-05** CANNOT be configured if the outside temperature is $\leq 5^{\circ}\text{C}$. In this case, error 65-03 is shown and the unit stops working. Change the setting to **19(29)-0-04**.
- The setting CANNOT be configured if there are alerts or errors present.
- If booster fans are used, you can ONLY configure setting **19(29)-0-03**.
- Settings **19(29)-0-04** and **19(29)-0-05** can be configured for multiple units with 1 controller.

17.3.2 Independent system

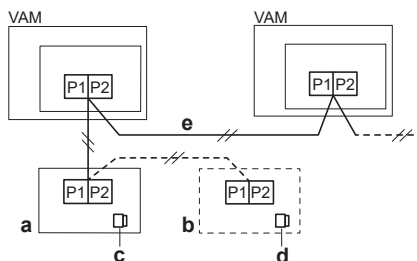

- a** Master controller for VAM
- b** Slave controller for VAM
- c** Switch position: Master
- d** Switch position: Slave

- e Maximum length of connection line: 500 m
VAM VAM heat reclaim ventilation unit

**NOTICE**

Factory settings: Do NOT change the switch settings when a controller is connected. SS1 is a setting switch to operate the unit without controller. Changing the switch setting when a controller is connected will stop the unit from operating normally. Keep the switch on the PCB in the factory setting position.

**NOTICE**

Group control connection is NOT allowed.

17.3.3 1-group linked-control system

**NOTICE**

Group control connection is NOT allowed with EKVDX indoor units.

- The air conditioner's controller can be used to control up to 16 units, a combination of indoor air conditioner units and heat reclaim ventilation units.
- You can configure initial settings for the functions of the VAM units. These functions are precool/preheat, ventilation air flow, ventilation mode, and fresh-up. Use the air conditioner's controller to configure the initial settings for the VAM units. See "17.2 Field settings" [▶ 73].

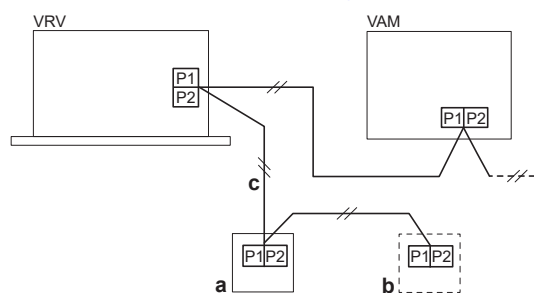

- a** Controller for air conditioner
b Controller for air conditioner
c Maximum length of connection line: 500 m
VRV VRV indoor unit
VAM VAM heat reclaim ventilation unit

17.3.4 Linked control with more than 2 groups

**NOTICE**

Group control connection is NOT allowed with EKVDX indoor units.

To change the settings, P1/P2 of the controller MUST be connected to the VAM units. The controller can be removed after the settings are changed.

If the unit is supposed to operate without controller, do NOT switch it on with the controller connected. Otherwise, the unit will give an error once the controller is removed, because it will keep on searching for the controller signal. To resolve the error, perform a power reset without the controller connected.

- The optional adapter PCB (KRP2A51) must be connected to 1 unit that is part of the F1/F2 loop. This unit can be an air conditioner or a VAM unit.
- Up to 64 units, a combination of air conditioners and VAM units, can be connected to the F1 and F2 terminals.

- KRP2A51 ONLY has ON/OFF control. If the VAM units run in automatic mode, they have a fixed setpoint. If P1/P2 is NOT connected, the setpoint of the air conditioner is unknown.
- Use the air conditioner's controller to configure the initial settings.

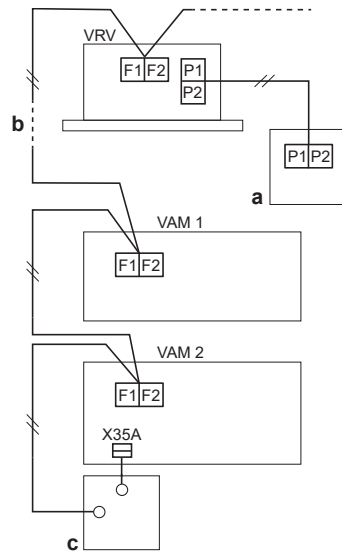

- a** Controller for air conditioner
- b** Maximum length of connection line: 1000 m
- c** Adapter PCB for remote control (KRP2A51)
- VRV** VRV indoor unit
- VAM 1** VAM heat reclaim ventilation unit 1
- VAM 2** VAM heat reclaim ventilation unit 2

Activate setting **17-8-02** to set the central zone link to ON. No further settings are required.

17.3.5 Direct duct connection



NOTICE
Direct duct connection is NOT allowed with EKVDX indoor units.

The line connections are the same as for the 1-group linked-control system.

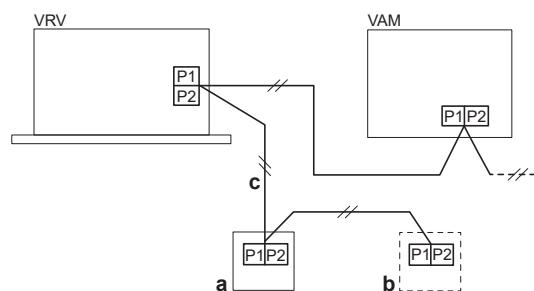

- a** Controller for air conditioner
- b** Controller for air conditioner
- c** Maximum length of connection line: 500 m
- VRV** VRV indoor unit
- VAM** VAM heat reclaim ventilation unit

Initial settings

Activate below setting for direct duct connection. This direct duct configuration ONLY works if P1/P2 is connected.

- Mode number: **17**
- Switch number: **5**

- Position number: 07

Other functions

Like in a 1-group linked-control system, other VAM functions can also be configured.

17.3.6 Central control system

To change the settings, P1/P2 of the controller MUST be connected to the heat reclaim ventilation units. The controller can be removed after the settings are changed.

If the unit is supposed to operate without controller, do NOT switch it on with the controller connected. Otherwise, the unit will give an error once the controller is removed, because it will keep on searching for the controller signal. To resolve the error, perform a power reset without the controller connected.

All control

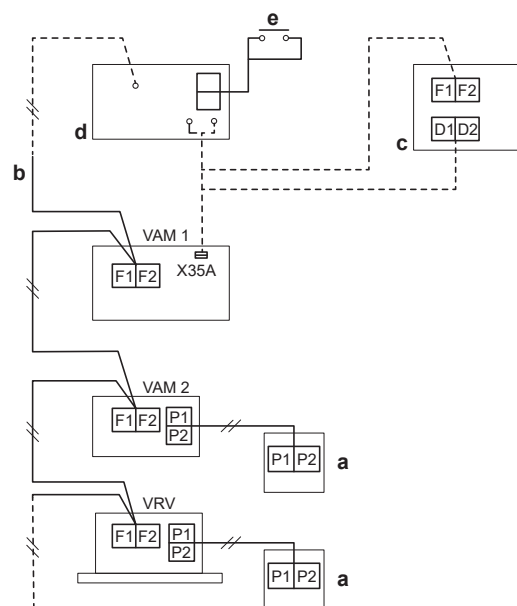

- a** Controller for air conditioner
- b** Maximum length of connection line: 1000 m
- c** Schedule timer (DST301B51)
- d** Adapter PCB for remote control (KRP2A51)
- e** On/Off signal
- VAM 1** VAM heat reclaim ventilation unit 1
- VAM 2** VAM heat reclaim ventilation unit 2
- VRV** VRV indoor unit

If you use the adapter PCB (KRP2A51) or schedule timer (DST301B51), the following is valid:

- Up to 64 units, a combination of air conditioners and VAM units, can be connected to the F1 and F2 terminals.
- This system does NOT require group number setting for central control (auto-address system). The central control group number is automatically assigned if the adapter PCB (KRP2A51) or schedule timer (DST301B51) is connected.
- The adapter PCB and the schedule timer CANNOT be used together. The adapter PCB allows on/off control. The schedule timer allows on/off control with a weekly schedule.
- The adapter PCB can be connected to the electric component mounting base of either the VAM unit or the air conditioner.

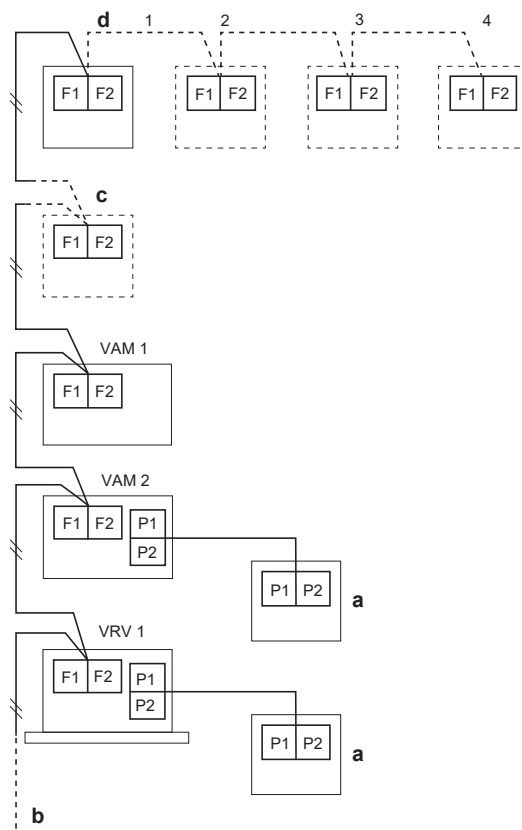
All/individual control

- a** Controller for air conditioner
- b** Maximum length of connection line: 1000 m
- c** Schedule timer
- d** ON/OFF controller
- VAM 1** VAM heat reclaim ventilation unit 1
- VAM 2** VAM heat reclaim ventilation unit 2
- VRV 1** VRV indoor unit 1

If the ON/OFF controller (DCS301B51) is used, the following is valid:

- Up to 64 units, a combination of air conditioners and VAM units, can be connected to the F1 and F2 terminals.
- Up to 4 ON/OFF controllers can be connected.
- A central control group number must be assigned to each VAM unit and air conditioner. See "The central control group number setting" in the operation manual of the ON/OFF controller for information about setting the group number.
- Use the air conditioner's controller to configure the initial settings.

Example

Setting the central control group number **2-05** to **1**:

Use the local setting on the controller to set the central control group number.

Mode number: **00**

Central control group number: **2-05**

Zone control

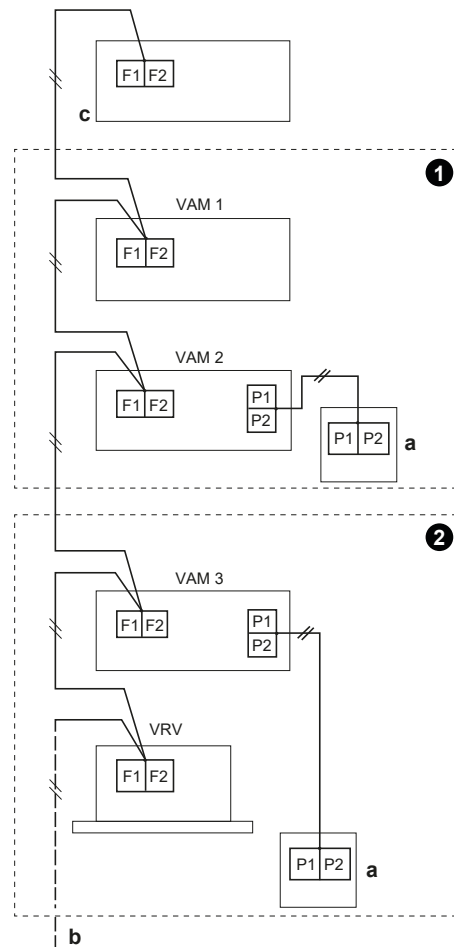

① Zone 1

② Zone 2

a Controller for air conditioner

b Maximum length of connection line: 1000 m

c Central controller (DCS302C51 or DCS601C51 or DCM601A51)

VAM 1 VAM heat reclaim ventilation unit 1

VAM 2 VAM heat reclaim ventilation unit 2

VAM 3 VAM heat reclaim ventilation unit 3

VRV VRV indoor unit

- Up to 64 units, a combination of air conditioners and VAM units, can be connected to the F1 and F2 terminals.
- Zone 1 and 2 can be controlled independently with the central controller.

Zone 2

The VAM units operate in the zone-linked mode, as described in "17.3.4 Linked control with more than 2 groups" [▶ 77].

Initial settings:

- A central control group number must be assigned to each VAM unit and air conditioner. See "The central control group number setting" in "All/individual control" [▶ 80] for information about setting the group number.
- For the ventilation air flow setting, follow the procedure described in "All control" [▶ 79].
- For zone setting using the central controller, see the operation manual of the central controller.
- The central controller can be used to control individual units in the zone for ventilation.

17.3.7 EKVDX option - extra settings

In case of a EKVDX +VAM combination, the following specific VAM settings can be made:

Automatic cool-heat switching function

The automatic cool-heat switching function, in case the EKVDX option is used, is only possible using the user interface.

To use this function, do the following:

- 1** Choose setting **1c-01-02**.
- 2** The Auto operation mode logic depends on the set setpoint logic via the Madoka app.
 - Single set point (shared set point heating and cooling).
 - Dual set point (set point for heating and cooling).
- 3** Choose guard timer duration using setting **1e-11**.
- 4** To switch the temperature
 - with the guard timer (=SP C1): choose setting **1c-14**.
 - immediately (=C1 C2): choose setting **1c-15**.

Mode	SW	SW description	01	02	03	04
1c	01	Which thermistor to show on user interface	Indoor unit (R1T)	User interface	—	—
1c	14	User interface auto mode: switching temperature with guard timer	0.5°C	1°C	1.5°C	2°C
1c	15	User interface auto mode: immediate switching temperature	0.5°C	1°C	1.5°C	2°C
1e	11	User interface auto mode: guard timer duration	15 min	30 min	60 min	90 min

Fan tap/air flow rate

In case the heat reclaim ventilation unit is combined with an EKVDX, the airflow rates in the L-tap are the same as in the H-tap. No action from the user is needed.

To determine the heat reclaim ventilation unit fan tap/airflow rate in case of combination with EKVDX:

Via user interface:

- Weak (L/H tap)
- Strong (UH tap)

Onsite setting:

Mode	SW	SW position	Description
17(27)	4	1	L/H-tap
		2	UH-tap

17.4 About the controller

17.4.1 BRC1E53 controller



NOTICE

This controller is NOT allowed in combination with EKVDX indoor units.

Please read the manual supplied with the controller (BRC1E53) for more detailed instructions.

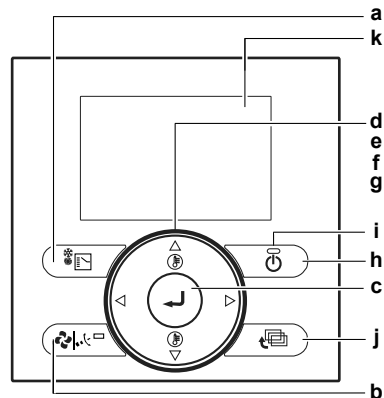

- a Operation Mode Selector button
- b Fan Speed/Airflow Direction button
- c Menu/Enter button
- d Up button
- e Down button
- f Right button
- g Left button
- h ON/OFF button
- i Operation lamp
- j Cancel button
- k LCD (with backlight)

To change the ventilation rate

- 1 Press the Menu/Enter button to display the main menu.
- 2 Press the Up/Down buttons to select Ventilation and press the Menu/Enter button.

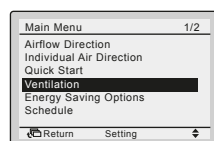

- 3 Press the Up/Down buttons to select Ventilation Rate and press the Menu/Enter button.

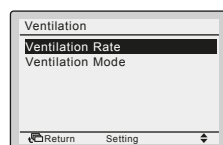

- 4 Press the Up/Down buttons to change the setting to Low or High and press the Menu/Enter button to confirm.

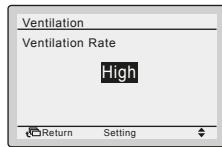

To select ventilation mode

Ventilation mode is used when cooling or heating is NOT necessary, so ONLY the heat reclaim ventilation units are operating.

- 1 Press the Operation Mode Selector button several times until the ventilation mode is selected.

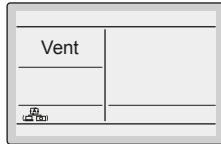

To change the ventilation mode

- 1 Press the Menu/Enter button to display the main menu.
- 2 Press the Up/Down buttons to select Ventilation and press the Menu/Enter button.

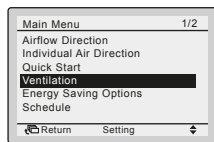

- 3 Press the Up/Down buttons to select Ventilation Mode and press the Menu/Enter button.

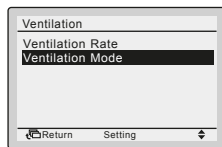

- 4 Press the Up/Down buttons to select the required ventilation mode. For more information about ventilation modes, see "[Ventilation modes](#)" [▶ 84].

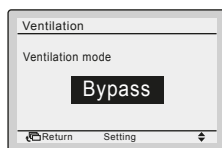

Ventilation modes

You can change the ventilation mode in the main menu.

Mode	Description
Auto mode	Using information from the air conditioner (cooling, heating, fan, and set temperature) and heat reclaim ventilation unit (indoor and outdoor temperatures), this mode automatically switches between Heat Reclaim Ventilation mode and Bypass mode.
Heat Reclaim Ventilation mode (Energy Reclaim Ventilation)	Outdoor air is supplied to the room after passing through a heat exchange element, where heat is exchanged with the room air.

Mode	Description
Bypass mode	The outdoor air bypasses the heat exchange element. This means that outdoor air is supplied to the room without heat exchange with the room air.

Time to clean filter indication

When the filter pressure drop becomes too large, the following message or icon is displayed at the bottom of the basic screen: Time to clean filter or . Clean the filters. For more information, see "[8 Maintenance and service](#)" [▶ 24].

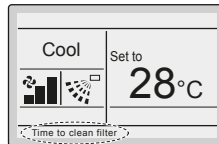

To remove the Time to clean filter indication

- 1 Press the Menu/Enter button.
- 2 Press the Up/Down buttons to select Reset Filter Indicator.
- 3 Press the Menu/Enter button.

Result: You return to the basic screen. The Time to clean filter indication is no longer displayed.

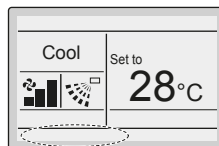
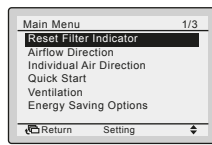

About error indications

If an error occurs, there is an error icon in the basic screen and the operation lamp blinks. If a warning occurs, ONLY the error icon blinks and the operation lamp does NOT. Press the Menu/Enter button to display the error code or warning and contact information.

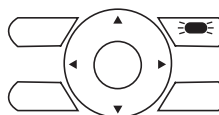
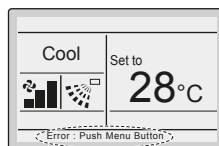

The error code blinks and the contact address and model name appear as shown below. In this case, notify your dealer about the error code.

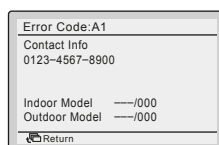

17.4.2 BRC301B61 controller









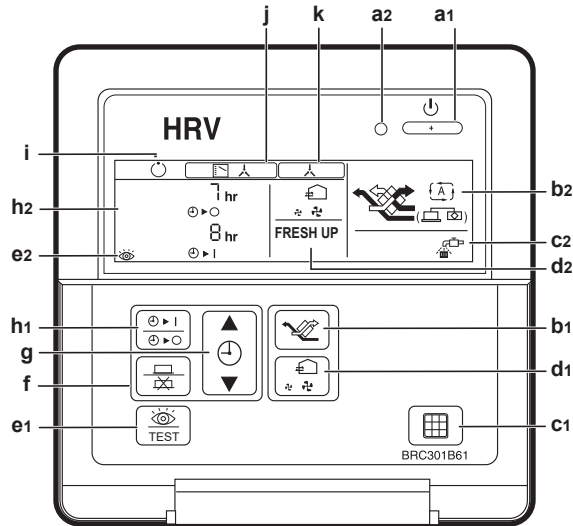





NOTICE



This controller is NOT allowed in combination with EKVDX indoor units.

For non-independent systems, starting, stopping and setting a timer is NOT possible with this controller (BRC301B61). In such cases, use the air conditioner controller (BRC1E53) or the central controller.





Item	Description
a	On/OFF
	a1 Operation/Stop button Press this button once and the unit starts to operate. Press this button again and the unit stops.
	a2 Operation lamp This red pilot lamp lights up while the unit is in operation.
b	Ventilation mode
	b1 Ventilation mode changeover button
	b2 Ventilation mode changeover display
	 Automatic mode The unit's temperature sensor automatically changes the operation mode of the unit to bypass mode or Heat Reclaim Ventilation mode.
 Heat Reclaim Ventilation mode The outdoor air passes through the heat exchange element to effect Heat Reclaim Ventilation.	
 Bypass mode The outdoor air does NOT pass through the heat exchange element, but bypasses it to deliver cooler air.	

Item	Description	
c	Air filter cleaning	
	c1	Filter signal reset button
	c2	 Indication of air filter cleaning. When you see this symbol, clean the air filter.
d	Air flow rate	
	d1	Air flow rate changeover button
	d2	Air flow rate changeover display
		Low
		High
	No FRESH UP (fresh-up) indication: The volume of outdoor air supplied into the room and that of the room air exhausted outdoors is equal.	
	 FRESH UP	Low fresh-up
	 FRESH UP	High fresh-up
	<p>If the fresh-up setting is set to "Fresh-up air supply", the volume of outdoor air supplied into the room is larger than that of room air exhausted outdoors. This prevents odours and moisture from kitchens and toilets from flowing into the room. This is the factory setting.</p> <p>If the fresh-up setting is set to "Fresh-up air exhaust", the volume of room air exhausted outdoors is larger than that of outdoor air supplied into the room. This prevents hospital odours and airborne micro-organisms from flowing out of the room into the corridors. To change the fresh-up settings, see "17.2 Field settings" [▶ 73].</p>	
	e	Inspection
e1		Inspection button Use this button ONLY when servicing the unit.
e2		Inspection indication
f	Programming	
	 	Programming button
g	Time adjustment	
		Time adjustment button
h	Schedule timer	
	h1	  Schedule timer button This button enables or disables the schedule timer.
	h2	Schedule timer display

Item	Description	
i	Indication of operation standby	
		<p>This icon indicates that the unit is precooling/preheating. The unit's start-up is delayed until precooling/preheating is finished.</p> <p>Precooling/preheating means that the heat reclaim ventilation units are NOT started while linked air conditioners are starting up, for example, before office hours.</p> <p>During this period, the cooling or heating load is reduced to bring the room temperature to the set temperature in a short time.</p>
j	Indication of operation control method	
		<p>Only applies to systems where the operation of heat reclaim ventilation units is linked to the air conditioners. While this indication is displayed, you CANNOT turn the heat reclaim ventilation units on or off with the controller of the heat reclaim ventilation units.</p>
k	Indication of central control	
		<p>Only applies to systems where a controller for air conditioners or devices for central control are connected to the heat reclaim ventilation units.</p> <p>While this indication is displayed, you may NOT be able to turn the heat reclaim ventilation units on or off, or use the timer function with the controller of the heat reclaim ventilation unit.</p>

To set the timer

- 1 Press the schedule timer button .
- 2 Press the time adjustment button  to set the time.
- 3 Press the programming button  to save the setting.

17.4.3 BRC1H controller



INFORMATION

Please refer to the Installer and user reference guide of the BRC1H remote controller.

17.4.4 BRC1K controller



INFORMATION

Please refer to the installer and user reference guide of the BRC1K remote controller.

17.5 Detailed explanation of settings

17.5.1 About fresh-up operation

Purpose

When combined with a local ventilation fan, such as the ones in bathrooms or kitchens, the air flow rate of the heat reclaim ventilation unit is balanced by either fan operation or exhaust operation. However, a circuit with voltage and low current (16 V, 10 mA) is formed between JC and J1, so you MUST use a relay with low-load contact.

Function

The unit performs overcharged operation to prevent odour flowing back.

Necessary parts

Operation contact of exhaust ventilation fan (field supply)

Example of control wiring:

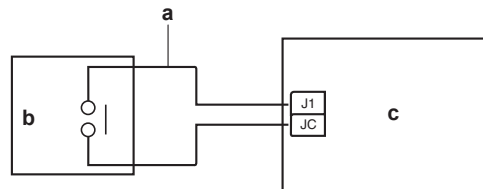

- a Connecting line can be extended to up to 50 m
- b Fan (field supply)
- c PCB

System description:



- a Local ventilation fan
- b Power supply

You can select either excessive supply mode or excessive exhaust mode. This function creates a more comfortable environment.

	Supply Fresh-up	Exhaust Fresh-up
Detail	Supply air volume can be set at a higher level than the exhaust air by the controller.	Exhaust air volume can be set at a higher level than the supply air by the controller.
Main effects	<ul style="list-style-type: none"> ▪ Prevents inflow of toilet odours. ▪ Prevents inflow of hot/cold outdoor air. 	<ul style="list-style-type: none"> ▪ Prevents outflow of airborne infectants from hospital rooms. ▪ Prevents outflow of odours from rooms in nursing homes.
Application	Offices, etc.	Hospitals, nursing homes, etc.

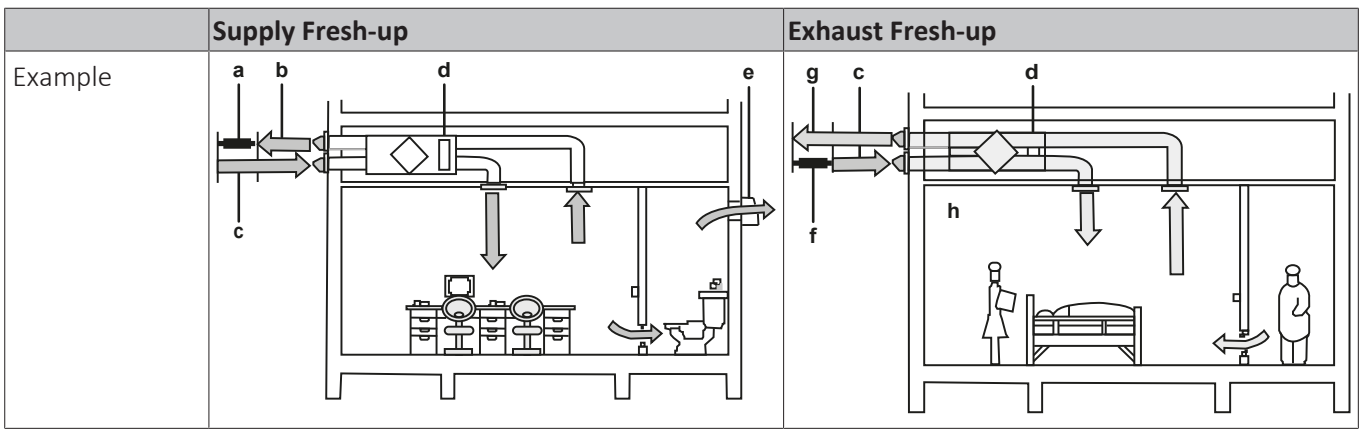

- a Part of supply fresh-up operation
- b Air exhaust
- c Air supply
- d Heat reclaim ventilation unit
- e Normal ventilation fan
- f Part of exhaust fresh-up operation
- g Air exhaust
- h Patient room

If an external fan is connected to J1 and JC, take the following into account:

- Setting **19(29)-0-03** MUST be configured, because otherwise the filter cleaning indication will be displayed at the wrong time.
- Make sure that setting **18(28)-8** is still set to **01** (fresh-up).
- Setting **18(28)-7** selects exhaust air or supply air fresh-up and whether the controller indicates that fresh-up is active.
- The following table describes the unit's operation based on setting **1A-3** and J1, JC:

Setting ^(a)	Description	J1/JC Normally open	J1/JC Normally closed
1A-3-01	Fresh-up "OFF" (factory setting)	Normal	Fresh-up
1A-3-02	Fresh-up "ON"	Fresh-up	Fresh-up

^(a) See "17.2 Field settings" [▶ 73].

The unit's fresh-up operation corresponds with the following fan operation:

	Supply Fresh-up		Exhaust Fresh-up	
	Supply	Exhaust	Supply	Exhaust
Weak	High	Low	Low	High
Strong	Ultra high	High	High	Ultra high

17.5.2 About the external damper operation

Function

Intake of outdoor air when the heat reclaim ventilation unit is off can be prevented if an external damper is incorporated in the system.

The heat reclaim ventilation's main unit PCB operates the heat reclaim ventilation and provides a signal for the external damper.

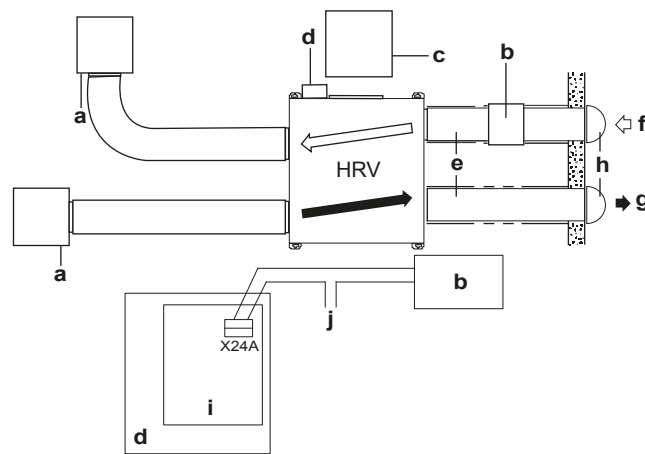

- a Air suction/discharge grille
- b External damper (field supply)
- c Inspection hole
- d Switch box
- e Heat insulation
- f Outdoor air (fresh air from outdoors)
- g Exhaust air (exhaust air to outdoors)
- h Round shape hood
- i PCB
- j Power source

Essential wiring

See "15.2 Opening the switch box" [▶ 54].

X24A outputs a signal when the supply air fan or exhaust air fan is running. Configure setting 18(28)-3 to 03 or 04.

17.5.3 About the CO₂ sensor

With the CO₂ (carbon dioxide) sensor installed, you can adjust the ventilation volume in function of measured CO₂ concentration. The measured concentration value is compared to programmed trigger values. Make sure that the ventilation mode and air flow rate are set to automatic.

See "17.2 Field settings" [▶ 73] for the field setting overview.

- Use setting 19(29)-9-05 to give control to the CO₂ sensor.
- Use setting 19(29)-7 to shift the trigger values.
- Use setting 18(28)-6 to switch between linear and fixed control.
- Use setting 18(28)-4 for onsite setting.

	Linear control				Fixed control	
Initialising	20 minutes in high				20 minutes in high	
Measuring	Every 5 minutes				Every 20 minutes	
Evaluation	Every 30 minutes (average of 6 measurements)				Every 20 minutes	
Trigger value	Linear control (minutes)				Fixed control	
CO ₂ ppm ^(a)	UH ^(b)	H ^(c)	L ^(d)	Stop	Tap A	Tap B
≥1450	30	—	—	—	UH	UH
1300~1450	20	10	—	—	UH	UH
1150~1300	10	20	—	—	H	H
1000~1150	—	30	—	—	H	H

	Linear control			Fixed control		
850~1000 ^(e)	—	20	10	—	H	L
700~850	—	10	20	—	L	L
550~700	—	—	30	—	L	L
400~550	—	—	20	10	L	stop

- ^(a) CO₂ parts per million
- ^(b) Ultra High
- ^(c) High
- ^(d) Low
- ^(e) 1000: base concentration

Example

When the sensor measures 900 ppm in linear control, the unit runs in high mode for 20 minutes and the next 10 minutes in low mode, then measures again.

L-tap

L-tap is adopted in case of:

- EKVDX connection
- direct duct

Essential wiring

See "15.2 Opening the switch box" [▶ 54] and the installation manual that is delivered with the CO₂ sensor.

To remove the components

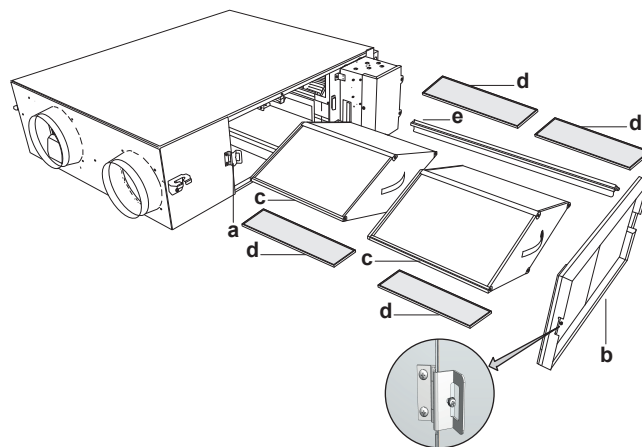

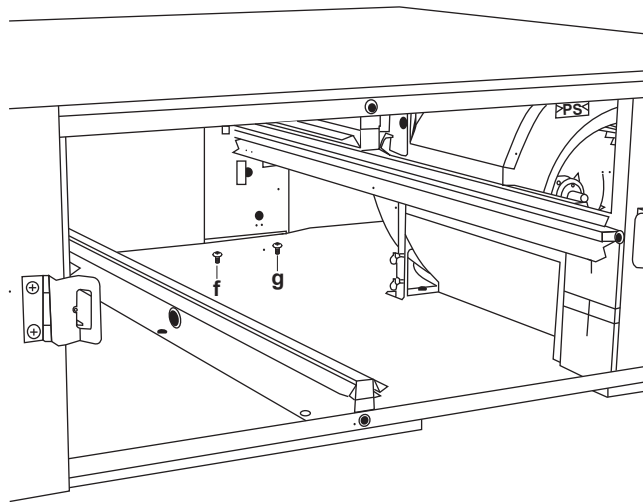

- a Hinge mechanism
- b Service cover
- c Heat exchange element
- d Air filter
- e Heat exchange element rail
- f Screw 1
- g Screw 2

- 1 Open the service cover hinge by loosening the screw.
- 2 Remove the service cover.
- 3 Remove the 2 heat exchange elements and the 4 air filters.
- 4 Remove the screw from the right heat exchange element rail.
- 5 Remove the heat exchange element rail.
- 6 Loosen screw 2, and remove screw 1.



INFORMATION

Use a crosshead screwdriver with a shank of more than 65 mm and a total length of less than 120 mm.

To install the CO₂ sensor

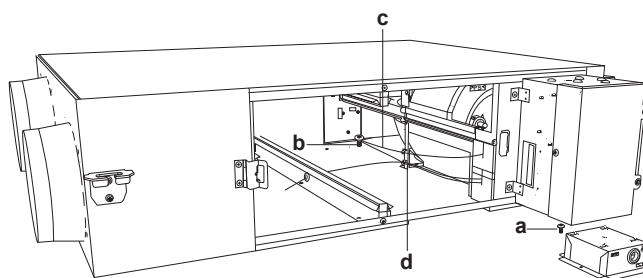

- a Screw 1
- b Screw 2
- c Damper motor wire
- d Clamp

- 1 Use the 2 screws to install the CO₂ sensor. See ["To remove the components"](#) [▶ 92] for details.



NOTICE

Make sure that the damper motor wire is NOT trapped under the kit.

To route the wiring of the carbon dioxide sensor

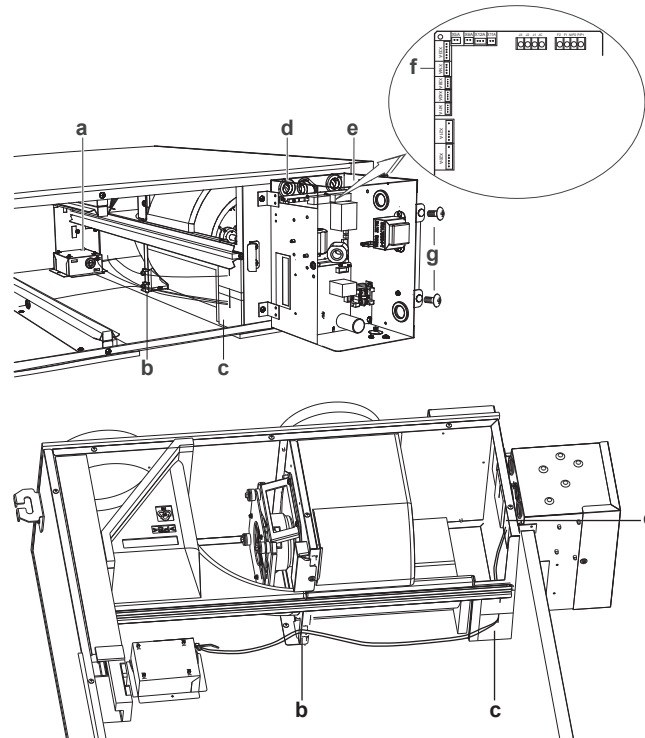

- a** CO₂ sensor
- b** Clamp
- c** Sealing material
- d** Bush
- e** Switch box
- f** X14A connector
- g** Screw

- 1 Remove the screws of the switch box cover.
- 2 Open the switch box.
- 3 Follow the same path with the CO₂ sensor wire as the damper switch (red) and thermistor (black) wires: through the bush inside the unit and through the left bush in the switch box.
- 4 Firmly insert the CO₂ sensor wire into the X14A connector.
- 5 Clamp the CO₂ sensor wire together with the damper switch (red) and thermistor (black) wires inside the switch box.
- 6 Cut the accompanying sealing material along the slit. Stick each piece on top of the sealing material that is attached to the bushing, in order to seal the gap around the CO₂ sensor wire.
- 7 Bundle the excess CO₂ sensor wire together with the damper switch (red) and thermistor (black) wires from the inside of the unit with the accompanying clamp.
- 8 Cut off the excess part of the clamp.



NOTICE

To install the heat exchanger rail correctly, the wire **MUST** be clamped.



NOTICE

When bundling the wires, make sure to open the control box completely.

To install the components

- 1 Close the switch box cover.
- 2 Install the components. Follow the reverse procedure of "To remove the components" [▶ 92].

17.5.4 About nighttime free cooling operation

Nighttime free cooling function

The nighttime free cooling function is an energy-conserving function that works at night, when the air conditioner is off. This reduces the cooling load in the morning, when the air conditioner is switched on. This is mainly for rooms that contain office equipment that raises the room temperature.

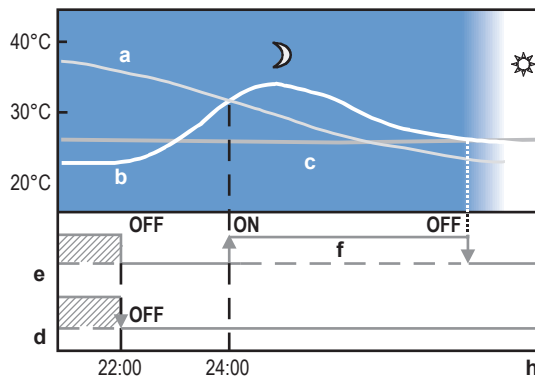

- a Outside temperature
- b Indoor temperature
- c Set temperature
- d Operating state of air conditioner
- e Operating state of heat reclaim ventilation unit
- f Nighttime free cooling operation

Explanation

The unit compares the indoor and outdoor temperatures after the air conditioning stops running for the night. If the conditions below are met, nighttime free cooling starts. When the indoor temperature reaches the air conditioning setting, nighttime free cooling stops.

Conditions

- The indoor temperature is higher than the air conditioning setting.
- The outdoor temperature is lower than the indoor temperature.

If the above conditions are NOT met, re-evaluation takes place every 60 minutes.



INFORMATION

Nighttime free cooling operation works when the heat reclaim ventilation unit is off, so it is NOT possible to stop this function.

Setting **17(27)-1** sets the number of hours that have to pass before the conditions for the free cooling function are checked.

Setting **17(27)-6** sets whether the fan runs in high or ultra high mode during the free cooling.

Setting **17(27)-7** sets the temperature.

**INFORMATION**

This function is NOT possible when the heat reclaim ventilation unit is NOT linked to an air conditioner.

17.5.5 About the precool and preheat function

When the precool/preheat function is set, the heat reclaim ventilation unit switches on at the configured time (30, 45, or 60 minutes) after the air conditioner starts cooling or heating. By default, this function is off. This function must be set with the controller of the air conditioner.

If the air conditioner is restarted within 2 hours after it has been stopped, this function is NOT started.

Setting **17(27)-2** enables this function.

Setting **17(27)-3** and setting **17(27)-9** set the delay for the start of the heat reclaim ventilation unit.

**INFORMATION**

This function is NOT possible when there is a direct duct connection.

**INFORMATION**

The preheating/precooling function of the heat reclaim ventilation unit is disabled when it is connected to an EKVDX.

17.5.6 About preventing a feeling of draft

When heating is on in a setup with air conditioner and the fan is turned off while the defrost operation is running, the fan of the heat reclaim ventilation unit is set to low mode or even stopped to prevent a feeling of draft.

Setting **17(27)-5** sets the fan mode.

**INFORMATION**

For EKVDX combinations, positions 2, 5, 6 and 9 of field setting **17(27)-5** are NOT allowed.

**INFORMATION**

This function is NOT possible when the heat reclaim ventilation unit is NOT linked to an air conditioner.

17.5.7 About 24-hour ventilation

When the controller is switched off, 24-hour ventilation starts. Setting **19(29)-4** enables this function and sets the fan speed.

**INFORMATION**

For EKVDX combinations, this operation is disabled. Default setting is **-4-01** and should not be changed.

17.5.8 About the ultra-low setting

If the amount of ventilation is too high, even in low mode, it is possible to have the fans work intermittently or at a very low speed with setting **19(29)-1**.

**INFORMATION**

This function is NOT possible when there is a direct duct connection.

**INFORMATION**

For EKVDX combinations, this operation is disabled. Default setting is **-1-01** and should not be changed.

17.5.9 About the electrical heater operation

If the electrical heater is used, set setting **19(29)-8** to **03** or **04** and setting **18(28)-9** to **01**. For more details, see the PCB heater manual.

**WARNING**

When combined with an EKVDX unit, do NOT install operating ignition sources (example: open flames, an operating gas appliance or an operating electric heater) in the duct work.

17.5.10 About external linkage input

Terminals J2 and JC function as contact signal input to switch the heat reclaim ventilation unit on or off.

**INFORMATION**

For EKVDX combinations, J2/JC function cannot be used. EKVDX is provided with T1T2 external input to replace these functions.

17.5.11 About filter contamination check

The filter contamination check can ONLY be done in the same conditions as **19(29)-0-04** or **05**. E.g., if the unit is operating in bypass mode, filter contamination CANNOT be checked. In this case, a timer counts the hours. After a target value is reached, the conditions are changed for a short time to be able to perform a filter contamination check.

Setting **18(28)-11-02** resets the timer to **0**.

Setting **18(28)-11-03** performs an immediate filter contamination check.

After finishing **18(28)-11-02** and **03**, the setting automatically returns to **18(28)-11-01** and unit operation continues as before. Settings **18(28)-11-02** and **03** can ONLY be used when setting **19(29)-0** is set to **01** or **02**.

**INFORMATION**

This function is not possible in case of errors.

**INFORMATION**

For more detailed instructions on installation and operation, field settings,... refer to the Installer and user reference guide of the EKVDX module.

18 Commissioning

In this chapter

18.1	Overview: Commissioning	98
18.2	Checklist before commissioning	98
18.3	Checklist during commissioning	99
18.3.1	About the system test run	99

18.1 Overview: Commissioning

After installation and once the field settings are defined, the installer is obliged to verify correct operation. Therefore a test run **MUST** be performed according to the procedures described below.

This chapter describes what you have to do and know to commission the system after it is configured.

Commissioning typically consists of the following stages:

- 1 Checking the "Checklist before commissioning".
- 2 Performing a test run.
- 3 If necessary, correcting errors after abnormal completion of the test run.
- 4 Operating the system.

18.2 Checklist before commissioning

- 1 After the installation of the unit, check the items listed below.
- 2 Close the unit.
- 3 Power up the unit.

Checklist

<input type="checkbox"/>	You have read the complete installation and operation instructions described in the installer and user reference guide .
<input type="checkbox"/>	Installation Check that the unit is properly installed, to avoid abnormal noises and vibrations when starting up the unit.
<input type="checkbox"/>	Power supply voltage Check the power supply voltage on the local supply panel. The voltage MUST correspond to the voltage on the nameplate of the unit.
<input type="checkbox"/>	Earth wiring Be sure that the earth wires have been connected properly and that the earth terminals are tightened.
<input type="checkbox"/>	Insulation test of the main power circuit Using a megatester for 500 V, check that the insulation resistance of 2 MΩ or more is attained by applying a voltage of 500 V DC between power terminals and earth. NEVER use the megatester for the interconnection wiring.
<input type="checkbox"/>	Internal wiring Visually check the switch box and the inside of the unit for loose connections or damaged electrical components.
<input type="checkbox"/>	Air inlet/outlet Check that the air inlet and outlet of the unit is NOT obstructed by paper sheets, cardboard, or any other material.

<input type="checkbox"/>	<p>Installation date and field setting</p> <p>Be sure to keep a record of the installation date on the sticker on the rear of the front panel according to EN60335-2-40 and keep record of the contents of the field setting(s).</p>
<input type="checkbox"/>	<p>Fuses, circuit breakers, or protection devices</p> <p>Check that the fuses, circuit breakers, or the locally installed protection devices are of the size and type specified in the chapter "15 Electrical installation" [▶ 49]. Be sure that no fuse or protection device is bypassed.</p>
<input type="checkbox"/>	<p>Field wiring</p> <p>Check that the field wiring has been carried out according to the instructions described in the chapter "15 Electrical installation" [▶ 49], according to the wiring diagrams and according to the applicable national wiring regulation.</p>
<input type="checkbox"/>	<p>Installation date and field setting</p> <p>Be sure to keep a record of the installation date on the sticker on the rear of the front panel according to EN60335-2-80 and keep record of the contents of the field setting(s).</p>
<input type="checkbox"/>	<p>EKVDX</p> <p>In case an EKVDX is installed, also see chapter Commissioning in the EKVDX installation and operation manual.</p>

18.3 Checklist during commissioning

<input type="checkbox"/>	To perform a test run .
--------------------------	--------------------------------

18.3.1 About the system test run

After completing the installation of the system, turn on the power of the heat reclaim ventilation units. Refer to the manual of the controller of each unit (controller for air conditioner, central controller, etc.) to conduct a trial operation.

19 Hand-over to the user

Once the test run is finished and the unit operates properly, make sure the following is clear for the user:

- Make sure that the user has the printed documentation and ask him/her to keep it for future reference. Inform the user that he/she can find the complete documentation at the URL mentioned earlier in this manual.
- Explain to the user how to properly operate the system and what to do in case of problems.
- Show the user what to do for the maintenance of the unit.
- Explain about energy saving tips to the user as described in the operation manual.

20 Maintenance and service



NOTICE

Maintenance **MUST** be done by an authorised installer or service agent.

We recommend performing maintenance at least once a year. However, applicable legislation might require shorter maintenance intervals.



NOTICE

Applicable legislation on **fluorinated greenhouse gases** requires that the refrigerant charge of the unit is indicated both in weight and CO₂ equivalent.

Formula to calculate the quantity in CO₂ equivalent tonnes: GWP value of the refrigerant × total refrigerant charge [in kg] / 1000

20.1 Overview: Maintenance and service

This chapter contains information about:

- Preventing electrical hazards when maintaining and servicing the system
- The maintenance of the heat reclaim ventilation unit.

20.2 Maintenance safety precautions



DANGER: RISK OF ELECTROCUTION



DANGER: RISK OF BURNING/SCALDING



NOTICE: Risk of electrostatic discharge

Before performing any maintenance or service work, touch a metal part of the unit in order to eliminate static electricity and to protect the PCB.

20.2.1 To prevent electrical hazards

When performing service to inverter equipment:

- 1** Do NOT perform electrical work for 10 minutes after turning off the power supply.
- 2** Measure the voltage between terminals on the terminal block for power supply with a tester and confirm that the power supply is shut off. In addition, measure points as shown in the figure, with a tester and confirm that the voltage of the capacitor in the main circuit is less than 50 V DC. If the voltage measured is still higher than 50 V DC, discharge the capacitors in a safe manner by using a dedicated capacitor discharge pen to avoid possibility of sparking.

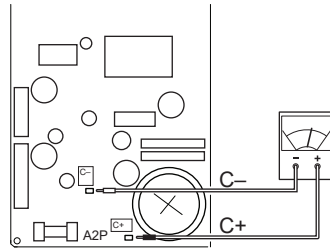
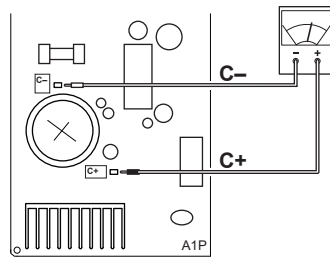
Models 350~650**Models 800~2000**

For details, refer to the wiring diagram on the outside of the service cover.

20.3 Checklist for maintenance of the heat reclaim ventilation unit

<input type="checkbox"/>	<p>Check the air filters at least once a year.</p> <p>The air filters can get blocked due to dust, dirt, leaves, etc. It is recommended to clean the air filters yearly. A blocked air filter can cause an excessive pressure drop and reduced performance. See "Maintenance of the air filter" [▶ 24].</p>
<input type="checkbox"/>	<p>Check the heat exchange element at least once every 2 years.</p> <p>The heat exchange element can get blocked due to dust, dirt, etc. It is recommended to clean the heat exchange element once every 2 years. A blocked heat exchange element can cause excessive pressure and reduced performance. See "Maintenance of the heat exchange element" [▶ 26].</p>

21 Troubleshooting

In this chapter

21.1	Overview: Troubleshooting.....	103
21.2	Precautions when troubleshooting.....	103
21.3	Solving problems based on error codes.....	103
21.3.1	Error codes: Overview.....	103

21.1 Overview: Troubleshooting

This chapter describes what you have to do in case of problems. It contains information about solving problems based on error codes.

Before troubleshooting

Carry out a thorough visual inspection of the unit and look for obvious defects such as loose connections or defective wiring.

21.2 Precautions when troubleshooting



WARNING

- When carrying out an inspection on the switch box of the unit, ALWAYS make sure that the unit is disconnected from the mains. Turn off the respective circuit breaker.
- When a safety device was activated, stop the unit and find out why the safety device was activated before resetting it. NEVER shunt safety devices or change their values to a value other than the factory default setting. If you are unable to find the cause of the problem, call your dealer.



DANGER: RISK OF ELECTROCUTION



WARNING

Prevent hazards due to inadvertent resetting of the thermal cut-out: power to this appliance MUST NOT be supplied through an external switching device, such as a timer, or connected to a circuit that is regularly turned ON and OFF by the utility.

21.3 Solving problems based on error codes

In case a malfunction code is shown on the display, consult the dealer where the unit was purchased.

21.3.1 Error codes: Overview

Code ^(a)	Description
<i>R1</i>	EEPROM failure
<i>R5</i>	Locked rotor
<i>R5-22</i>	Unstable fan rpm: failure of filter contamination check or failure of function 19(29)-0-04/-05

Code ^(a)	Description
<i>R6-28</i>	VAM air flow rate dropped below legal threshold limit (for R32 application) ^(b)
<i>R6-29</i>	VAM air flow rate approaches legal threshold limit (for R32 application) ^(b)
<i>R6-30</i>	VAM warning for air flow rate drop (for R32 application) ^(b)
<i>RB</i>	Power supply malfunction
<i>RJ</i>	Capacity setting malfunction
<i>E1</i>	Fan communication error
<i>E6</i>	Malfunction of fan motor sensor or fan control driver
<i>EH</i>	CO ₂ sensor warning
<i>U5</i>	Transmission error between unit and controller
<i>U8</i>	Transmission error between master controller and slave controller ^(c)
<i>UR</i>	Wrong controller installed
<i>UC</i>	Repeated central address
<i>UE</i>	Transmission error between unit and central controller
<i>UJ-36</i>	Miscommunication between VAM and EKVDX
<i>E0</i>	External protection device activated
<i>E4-01</i>	Indoor air thermistor (R1T) malfunction
<i>E4-02</i>	Indoor air thermistor (R1T) out of operation range
<i>E5-01</i>	Outdoor air thermistor (R2T) malfunction
<i>E5-02</i>	Outdoor air thermistor (R2T) out of operation range
<i>E5-03</i>	Functions 19(29)-0-04/-05 not possible due to low outdoor temperature
<i>ER</i>	Damper-related malfunction

^(a) In case of a code with a grey background, the VAM still operates. Inspect and repair the unit as soon as possible.

When connected to an EKVDX and the R32 safety system is active, the VAM can stop operating.

^(b) These error codes only apply when the R32 safety system is active. See Installation and operation manual of the EKVDX for more information about recovery of these errors.

^(c) When combined with the EKVDX, no slave controllers are allowed.

22 Disposal

**NOTICE**

Do NOT try to dismantle the system yourself: dismantling of the system, treatment of the refrigerant, oil and other parts **MUST** comply with applicable legislation. Units **MUST** be treated at a specialised treatment facility for reuse, recycling and recovery.

23 Technical data

- A **subset** of the latest technical data is available on the regional Daikin website (publicly accessible).
- The **full set** of the latest technical data is available on the Daikin Business Portal (authentication required).

In this chapter

23.1	Wiring diagram	106
23.2	Service space	109

23.1 Wiring diagram

The wiring diagram can be found on the outside of the service cover.

Legend for wiring diagrams:

A1P	Printed circuit board
A2P	Printed circuit board assy (fan) (VAM350~650)
A2P-A3P	Printed circuit board assy (fan) (VAM800+1000)
A2P~A5P	Printed circuit board assy (fan) (VAM1500+2000)
C7	Capacitor (M1F)
F1U (A1P)	Fuse (250 V, 6.3 A, T)
F2U (A2P)	Fuse (250 V, 5 A, T) (VAM350~650)
F3U	Fuse (250 V, 6.3 A, T) (VAM800~2000)
F4U (A2P)	Fuse (250 V, 6.3 A, T) (VAM350~650)
HAP	Pilot lamp (service monitor - green)
K*R	Magnetic relay
L*R	Reactor
M1D	Motor (damper)
M2D	Motor (damper) (VAM1500+2000)
M1F	Supply air fan
M2F	Exhaust air fan
M3F	Motor (exhaust air fan) (top) (VAM1500+2000)
M4F	Motor (supply air fan) (top) (VAM1500+2000)
PS	Switching power supply
Q1DI	Field earth leak detector (≤ 300 mA)
R*	Resistance
R1T	Thermistor (indoor air)
R2T	Thermistor (outdoor air)
R3T	Thermistor (PTC)
S1C	Limit switch damper motor

S2C	Limit switch damper motor (VAM1500+2000)
V1R	Diode bridge
X1M (A1P)	Terminal
X2M (A1P)	Terminal (outside input)
X3M	Terminal (power supply)
Z1F	Noise filter
Z*C	Noise filter (ferrite core)





Remote controller

SS1	Selector switch
-----	-----------------

Connector for option

X14A	Connector (CO ₂ sensor)
X24A	Connector (outside damper)
X33A	Connector (contact printed circuit board)
X35A	Connector (power supply printed circuit board)

Symbols:

	Field wiring
	Terminals
	Connectors
	Protective earth
	Noiseless earth

Colours:

BLK	Black
BLU	Blue
BRN	Brown
GRN	Green
ORG	Orange
RED	Red
WHT	White
YLW	Yellow

Translation of text on wiring diagram

English	Translation
Notes	Notes
X35A is connected when optional accessories are being used, see wiring diagram of this accessory	X35A is connected when optional accessories are being used, see wiring diagram of this accessory

English	Translation
An EKVDX unit and its corresponding VAM-J* unit should be connected to a common power supply. Refer to the installation manual of the EKVDX unit for further details.	An EKVDX unit and its corresponding VAM-J* unit should be connected to a common power supply. Refer to the installation manual of the EKVDX unit for further details.
Transmission wiring	Transmission wiring
Ext. output - error state	External output - error state
Ext. output - R32 alarm	External output – R32 alarm
Caution when performing service inside the el. compo. box	Caution when performing service inside the electrical component box.
Caution for ELECTRIC SHOCK	Caution for ELECTRIC SHOCK
Do not open the el. compo. box cover for 10 minutes after the power supply is turned off.	Do not open the electrical component box cover for 10 minutes after the power supply is turned off.
After opening the el. compo. box, measure (on A1P~A5P) the points shown at the right with a tester and confirm that the voltage of the capacitor in the main circuit is less than DC50V.	After opening the electrical component box, measure (on A1P~A5P) the points shown at the right with a tester and confirm that the voltage of the capacitor in the main circuit is less than DC50V.
Measuring points for voltage	Measuring points for voltage
Printed circuit board	Printed circuit board

23.2 Service space

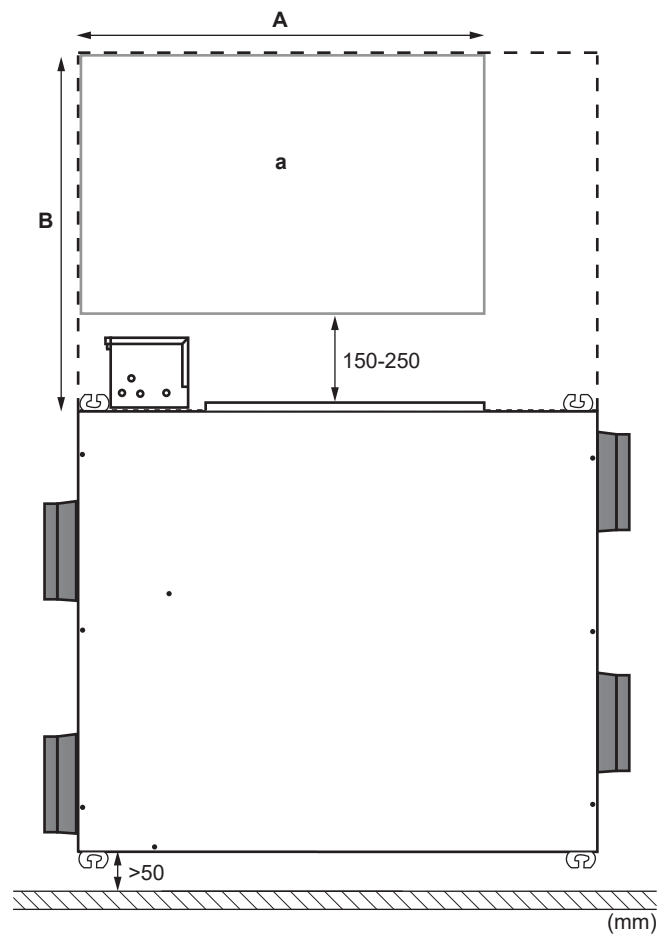

a Service space

Models	A	B
VAM350+500	900 mm	675 mm
VAM650	1100 mm	700 mm
VAM800~2000	1100 mm	850 mm

24 Glossary

Dealer

Sales distributor for the product.

Authorised installer

Technical skilled person who is qualified to install the product.

User

Person who is owner of the product and/or operates the product.

Applicable legislation

All international, European, national and local directives, laws, regulations and/or codes that are relevant and applicable for a certain product or domain.

Service company

Qualified company which can perform or coordinate the required service to the product.

Installation manual

Instruction manual specified for a certain product or application, explaining how to install, configure and maintain it.

Operation manual

Instruction manual specified for a certain product or application, explaining how to operate it.

Maintenance instructions

Instruction manual specified for a certain product or application, which explains (if relevant) how to install, configure, operate and/or maintain the product or application.

Accessories

Labels, manuals, information sheets and equipment that are delivered with the product and that need to be installed according to the instructions in the accompanying documentation.

Optional equipment

Equipment made or approved by Daikin that can be combined with the product according to the instructions in the accompanying documentation.

Field supply

Equipment NOT made by Daikin that can be combined with the product according to the instructions in the accompanying documentation.

