

Installer reference guide  
Daikin HomeHub

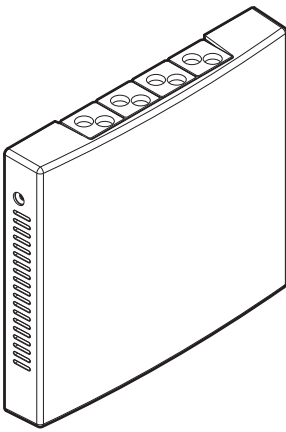

EKRHH ▲

▲ = , , A, B, C, ..., Z

# Table of contents

<b>1</b>	<b>About this document</b>	<b>4</b>
<b>2</b>	<b>About the Daikin HomeHub</b>	<b>5</b>
2.1	Components .....	6
2.2	Basic parameters .....	6
2.3	Compatibility .....	7
2.4	System requirements .....	9
2.5	Network requirements.....	11
2.6	Combination with ONECTA .....	11
<b>3</b>	<b>About the box</b>	<b>12</b>
3.1	To unpack the adapter .....	12
<b>4</b>	<b>Preparation</b>	<b>13</b>
4.1	Installation site requirements .....	13
4.2	Overview of electrical connections.....	14
<b>5</b>	<b>Installation</b>	<b>16</b>
5.1	Precautions when installing the Daikin HomeHub .....	16
5.2	Opening and closing the Daikin HomeHub .....	16
5.2.1	To open the Daikin HomeHub .....	16
5.2.2	To close the Daikin HomeHub .....	17
5.3	Connecting the electrical wiring .....	17
5.3.1	To connect the electrical wiring .....	17
5.4	Mounting the Daikin HomeHub .....	20
5.4.1	To mount the Daikin HomeHub.....	20
<b>6</b>	<b>Application examples</b>	<b>21</b>
6.1	Use case 1 - PV self-consumption for Daikin Altherma .....	21
6.2	Use case 2 - PV self-consumption for Multi+(DHW).....	21
6.3	Use case 3 - Modbus TCP/IP or RTU for Daikin Altherma .....	22
6.3.1	Third-party integrations.....	22
6.3.2	Smart Grid for utilities .....	23
6.4	Use case 4 - Modbus TCP/IP or RTU for air-to-air heat pump .....	23
6.5	Use case 5 - EEBUS for Daikin Altherma .....	24
<b>7</b>	<b>Use case 1 - PV self-consumption for Daikin Altherma</b>	<b>26</b>
7.1	Energy sensor .....	26
7.2	About PV optimisation .....	28
7.2.1	Schedules .....	30
7.2.2	Behaviour to safeguard unit reliability.....	30
7.3	Energy buffering.....	31
7.3.1	Buffering in case [C-07] = 0 [LWT control] .....	33
<b>8</b>	<b>Use case 2 - PV self-consumption for Multi+(DHW)</b>	<b>34</b>
8.1	Energy sensor .....	34
8.2	About PV optimisation .....	36
8.2.1	Schedules .....	37
8.3	Energy buffering.....	38
<b>9</b>	<b>Use case 3 - Modbus TCP/IP or RTU for Daikin Altherma</b>	<b>39</b>
9.1	Modbus protocol.....	39
9.2	Modbus registers.....	39
9.2.1	Holding registers .....	41
9.2.2	Input registers.....	42
9.2.3	Special return values.....	44
9.3	Energy buffering with Smart Grid .....	45
9.3.1	Buffering in case [C-07] = 0 [LWT control] .....	47
<b>10</b>	<b>Use case 4 - Modbus TCP/IP or RTU for air-to-air heat pump</b>	<b>48</b>
10.1	Modbus protocol.....	48
10.2	Modbus registers.....	48
10.2.1	Holding registers .....	49
10.2.2	Special return values.....	49
10.3	Smart Grid & Demand control .....	50
10.3.1	Smart Grid for air-to-air heat pump .....	50
10.3.2	Demand control for air-to-air heat pump .....	51

<b>11 Use case 5 - EEBUS for Daikin Altherma</b>	<b>53</b>
11.1 Limitation of Power Consumption (LPC).....	53
11.2 Monitoring of Power Consumption (MPC).....	53
11.3 Legal log.....	54
<b>12 Firmware updates</b>	<b>55</b>
<b>13 Configuration</b>	<b>56</b>
13.1 Overview of possible user interfaces.....	56
13.1.1 ONECTA app settings.....	56
13.1.2 WebUI settings.....	56
13.1.3 Daikin Altherma user interface settings.....	57
13.2 Settings for Use case 1.....	59
13.2.1 Daikin Altherma user interface settings.....	59
13.3 Settings for Use case 2.....	60
13.3.1 Daikin Altherma user interface settings.....	60
13.4 Settings for Use case 3.....	61
13.4.1 Daikin Altherma user interface settings.....	61
13.5 Settings for Use case 4.....	62
13.6 Settings for Use case 5.....	62
13.6.1 WebUI settings.....	62
<b>14 Troubleshooting</b>	<b>65</b>
14.1 Buttons.....	65
14.2 LED indication.....	65
14.3 Daikin Altherma user interface indications.....	67
14.4 Error codes: Overview.....	67
14.5 Behaviour during a connection loss.....	68
<b>15 Hand-over to the user</b>	<b>70</b>
<b>16 Glossary</b>	<b>71</b>

# 1 About this document

## Target audience

Authorised installers

## Documentation set

This document is part of a documentation set. The complete set consists of:

- **General safety precautions:**

- Safety instructions that you must read before installing
- Format: Paper (in the box of the indoor unit)

- **Installation manual:**

- Installation instructions
- Format: Paper (supplied in the kit)

- **Installer reference guide:**

- Preparation of the installation, good practices, reference data, ...
- Format: Digital files on <https://www.daikin.eu>. Use the search function 🔍 to find your model.

The latest revision of the supplied documentation is published on the regional Daikin website and is available via your dealer.

The original instructions are written in English. All other languages are translations of the original instructions.

## 2 About the Daikin HomeHub

The Daikin HomeHub (EKRHH) is a versatile smart solution that serves as a central hub to connect and control Daikin equipment. In addition, the Daikin HomeHub also functions as an interface for smart energy management and home control. This way, the compliance with the local BEG or §14a regulations is supported. The Daikin HomeHub allows for app control of a heat pump system and, depending on the model, allows for the integration of a heat pump system in a Smart Grid application.



### INFORMATION

The EKRHHA-CoC models are equivalent to the EKRHHA models from the software version 2.7.0 onwards.

Depending on the user needs, the Daikin HomeHub can be used in 2 different modes:

- As the main controller; for use case 1, 2, and 4. In this mode the Daikin HomeHub acts as the home energy management (HEM) system to optimise the energy consumption of a Daikin Altherma (use case 1) or Multi+(DHW) (use case 2) heat pump in combination with a PV system, or of an air-to-air heat pump (use case 4).
- As an interface; for use case 3 and 5. In this mode the Daikin HomeHub is used to control the Daikin Altherma heat pump from a home automation or home energy management (HEM) system or from a grid provider control box through a local interface.



### NOTICE

There can ONLY be 1 home energy management (HEM) system [Daikin HomeHub or third party] in a house. Using multiple HEM systems can result in the malfunctioning of one or more of them. In some special cases, an energy manager can be integrated in a home battery or an EV charging station. If there is already a HEM system installed in the house, it is better to use the Daikin HomeHub as an interface.

For more information on the Use cases, see "[6 Application examples](#)" [▶ 21].

## 2.1 Components

### Bottom

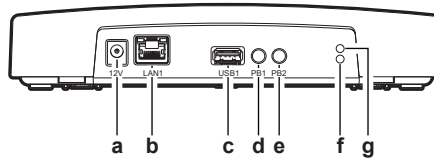

- a** DC power jack input (12~24 V)
- b** Ethernet port (LAN1)
- c** USB Type A port (USB1)
- d** Push button (PB1)
- e** Push button (PB2)
- f** LED (Blue)
- g** LED (Green)



#### INFORMATION

The USB Type A port is not intended to power or charge other devices.

### Top

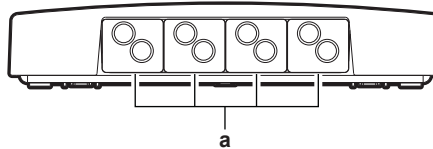

- a** Rubber grommets

## 2.2 Basic parameters

Parameter	Value
Power supply	DC 12~24 V
IP class	IP20

## 2.3 Compatibility

### Use case 1 - PV self-consumption for Daikin Altherma & Use case 3 – Modbus for Daikin Altherma

Unified MMI2 firmware version 7.8.0 or higher is required.

	Unit	Outdoor	Indoor		Hydro SW version/Micon ID
ASHP	Daikin Altherma 3 H HT	EPRA14/16/18DV37/W17	F	ETVH/X/Z16-E7	20017705 (short version: 0775)
			ECH <sub>2</sub> O	ETSH(B)/X(B)16-E7	
			W	ETBH/X16-E7	
	Daikin Altherma 3 H MT	EPRA08/10/12EV3/W1	F	ETVH/X/Z12-E	20007903 (short version: 0793)
			ECH <sub>2</sub> O	ETSH(B)/X(B)12-P-E	
			W	ETBH/X12-E	
	Daikin Altherma 3 R	ERGA-EV(7)(H)(A)	F	EHVH/X/Z-E <sup>(a)</sup>	20002203 (short version: 0223)
			ECH <sub>2</sub> O	EHS(B)/X(B)-P-E	20017704 (short version: 0774)
			W	EBH/X-E <sup>(a)</sup>	20002203 (short version: 0223)
	Daikin Altherma 3 R	ERLA11/14/16DV3/W1	F	EBVH/X/Z-D	20007903 (short version: 0793)
			ECH <sub>2</sub> O	EBSH(B)/X(B)-D	
			W	EBBH/EBBX-D	
	Daikin Altherma 3 R MT	ERRA-EV3/W1	F	ELVH/X/Z-E	22009C01 (short version: 29C1)
			ECH <sub>2</sub> O	ELSH(B)/X(B)-E	
W			ELBH/X-E		
Daikin Altherma 3 M	EBLA09/11/14/16D <sup>(a)</sup> EDLA09/11/14/16D <sup>(a)</sup>	— <sup>(b)</sup>		20002203 (short version: 0223)	
Daikin Altherma 3 M	EBLA04/06/08E EDLA04/06/08E	— <sup>(b)</sup>		20017704 (short version: 0774)	

<sup>(a)</sup> The Modbus holding registers with offset 59 and 61 (Thermostat input) are not operational. See "9.2.1 Holding registers" [▶ 41].

<sup>(b)</sup> No indoor unit available for this type Daikin Altherma.

**Use case 2 - PV self-consumption for Multi+(DHW)**

Unified MMI2 firmware version 7.8.0 or higher is required.

Unit	Outdoor	Tank	Hydro SW version/ Micon ID
Daikin Multi+ (DHW) Step 1 <sup>(a)</sup>	4MWXM-A & 5MWXM-A	EKHWET90BAV3	21003301 (short version: 1331)
		EKHWET120BAV3	
		EKHWETU120BAV3	
Daikin Multi+ (DHW) Step 2	5MWXM-A	CKHWS180BJV3	24004001 (short version: 4401)
		CKHWS230BJV3	
		CKHWSU230BJV3	

<sup>(a)</sup> Since both outdoor units have their own operation range, the resulting operation might be different depending on the chosen outdoor unit.

**Use case 4 – Modbus for air-to-air heat pump**

All units supporting 4th generation WLAN adapter (BRP069C4\*) are compatible, as long as the connected outdoor unit supports Demand Control.

This use case is NOT compatible when more than 5 units are being connected.

**Use case 5 - EEBUS for Daikin Altherma**

Unified MMI2 firmware version 7.8.0 or higher is required.

	Unit	Outdoor	Indoor		Hydro SW version/Micon ID
ASHP	Daikin Altherma 3 H HT	EPRA14/16/18DV37/W17	F	ETVH/X/Z16-E7	20017705 (short version: 0775)
			ECH <sub>2</sub> O	ETSH(B)/X(B)16-E7	
			W	ETBH/X16-E7	
	Daikin Altherma 3 H MT	EPRA08/10/12EV3/W1	F	ETVH/X/Z12-E	20007903 (short version: 0793)
			ECH <sub>2</sub> O	ETSH(B)/X(B)12-P-E	
			W	ETBH/X12-E	
	Daikin Altherma 3 R	ERGA-EV(7)(H)(A)	F	EHVH/X/Z-E <sup>(a)</sup>	20002203 (short version: 0223)
			ECH <sub>2</sub> O	EHSB(B)/X(B)-P-E	
			W	EBBH/X-E <sup>(a)</sup>	
	Daikin Altherma 3 R	ERLA11/14/16DV3/W1	F	EBVH/X/Z-D	20007903 (short version: 0793)
			ECH <sub>2</sub> O	EBSB(B)/X(B)-D	
			W	EBBH/EBBX-D	
	Daikin Altherma 3 R MT	ERRA-EV3/W1	F	ELVH/X/Z-E	22009C01 (short version: 29C1)
			ECH <sub>2</sub> O	ELSB(B)/X(B)-E	
W			ELBH/X-E		
Daikin Altherma 3 M	EBLA09/11/14/16D <sup>(a)</sup> EDLA09/11/14/16D <sup>(a)</sup>	— <sup>(b)</sup>		20002203 (short version: 0223)	
Daikin Altherma 3 M	EBLA04/06/08E EDLA04/06/08E	— <sup>(b)</sup>		20017704 (short version: 0774)	

<sup>(a)</sup> The Modbus holding registers with offset 59 and 61 (Thermostat input) are not operational. See "9.2.1 Holding registers" [▶ 41].

<sup>(b)</sup> No indoor unit available for this type Daikin Altherma.

## 2.4 System requirements

Make sure the Daikin HomeHub software is ALWAYS up to date. The best system performance is achieved by updating all components to the latest available software. The requirements posed on the Daikin HomeHub system are as follows:

	Use case 1	Use case 2	Use case 3	Use case 4	Use case 5
User interface software of the Daikin Altherma or Multi+ (DHW) tank	7.8.0 or higher			—	7.8.0 or higher
ONECTA	Optional 3.21.1 or higher			Required 3.21.1 or higher	Required 3.40.1 or higher
Remote controller	Highly recommended	Optional			
WLAN adapter	Check your unit manual for the required WLAN adapter			BRP069C4* 1.28 or higher	Check your unit manual for the required WLAN adapter
Internet connection	Strongly recommended (for updates)			Required	Important <sup>(a)</sup>

<sup>(a)</sup> It is necessary for the activation of the use case and download of the legal log file.



**NOTICE**

It is **STRONGLY RECOMMENDED** to keep the Daikin HomeHub connected to the internet via a LAN cable to receive the latest security and feature updates. This will improve compatibility, security and efficiency of the Daikin HomeHub.

- For use case 4, the internet connection is strictly required for correct functioning of the use case.
- For use case 5, the internet connection is required to activate the use case and download the legal log file. It also improves the time synchronisation of the legal log. A LAN cable is required to enable the EEBUS protocol, however, no internet connection is needed for the use case to function correctly.



**NOTICE**

The Daikin HomeHub **CANNOT** be combined with a LAN adapter (BRP069A61/BRP069A62) or DCOM (DCOM-LT-MB/DCOM-LT-IO).

- If a LAN adapter/DCOM is already connected to the unit, you **CANNOT** add a Daikin HomeHub on the Daikin Altherma user interface.
- If you connect a LAN adapter/DCOM when a Daikin HomeHub is already connected, the Daikin HomeHub is disconnected.



**INFORMATION**

- For an overview of the possible use cases, see "[6 Application examples](#)" [▶ 21]. For more information about the electrical wiring, see "[4.2 Overview of electrical connections](#)" [▶ 14].
- Some tools and components might already be available on site. Before going on site, find out which components are already at hand, and which ones you need to provide (e.g. router, electricity meter, ...).

## 2.5 Network requirements

### Required network protocols

- **Multicast DNS (mDNS)** is needed for the discovery of the Daikin HomeHub, which advertises on the `_http._tcp.local.` service. The mDNS will broadcast port 80 for HTTP. For correct functioning, mDNS requires a single subnet and multicast traffic.
- **Hypertext Transfer Protocol (HTTP)** is needed for the onboarding of the Daikin HomeHub. The Daikin HomeHub exposes an HTTP REST server for communication.
- **Internet Group Management Protocol (IGMP)** MUST be activated and is only disabled by default in exceptional cases.

### Firewall settings

For optimal performance of the Daikin HomeHub, you need to have the following ports available:

Protocol	Port
HTTP	80
HTTPS	443
Local WebUI	8081
Modbus – no encryption	502
Modbus – TLS encryption	802

## 2.6 Combination with ONECTA

The Daikin HomeHub can be used in combination with the ONECTA app for all 5 use cases:

Use case	Combination with the ONECTA app
Use case 1, 2 and 3	It is optional and only allows to check and configure some basic information.
Use case 4	It is a required functionality.
Use case 5	It is optional, but recommended for user-friendliness (e.g. log download, configuration, ...)

To use the ONECTA app, it is required to connect the Daikin HomeHub via the app.



#### INFORMATION

If you want to move the Daikin HomeHub to a different location, you first need to offboard the device via the app and onboard it again on the new location.

## 3 About the box

Keep the following in mind:

- At delivery, the unit **MUST** be checked for damage and completeness. Any damage or missing parts **MUST** be reported immediately to the claims agent of the carrier.

### 3.1 To unpack the adapter

- 1 Open the box.
- 2 Take out the Daikin HomeHub.
- 3 Separate the accessories.

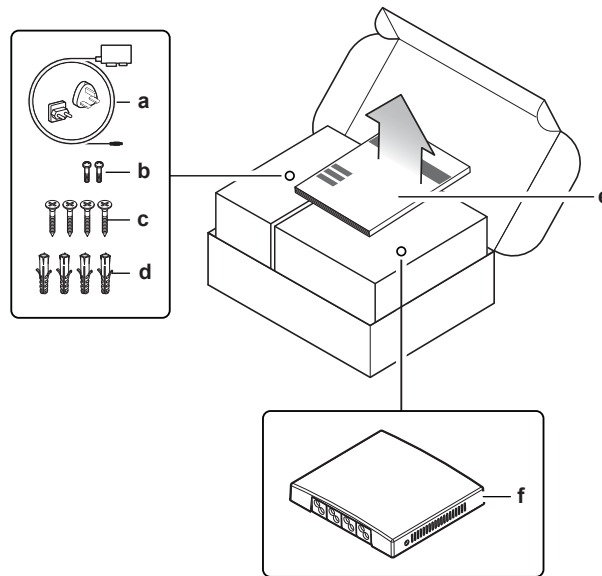

- a** AC/DC power adapter with regional plug adapters (EU/UK)
- b** Casing screws (x2)
- c** Mounting screws (x4)
- d** Wall plugs (x4)
- e** Installation manual
- f** Daikin HomeHub

## 4 Preparation

### 4.1 Installation site requirements

Do NOT install the Daikin HomeHub in the following places:

- In places where it is exposed to direct sunlight.
- In places where it is near a heat source.
- In places where it is exposed to a source of steam.
- In places where it is exposed to machine oil vapour.
- In places where it may be exposed to water, or in generally moist areas.

The Daikin HomeHub is designed:

- To be mounted in dry, indoor locations only.
- To be installed in a vertical orientation only.
- To operate in ambient temperatures ranging from  $-10\sim 50^{\circ}\text{C}$ .

Make sure a clean installation of the wired P1/P2 connections is possible.

Mind the following spacing installation guidelines:

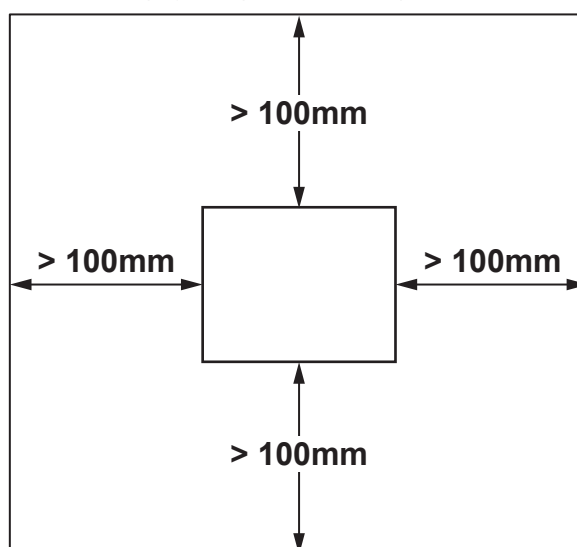

- Provide enough space (>100 mm) on the top side of the Daikin HomeHub to allow field wiring to enter through the rubber grommets.
- Provide enough space (>100 mm) on the left and right side of the Daikin HomeHub, so that a screwdriver can fit in order to remove or tighten the casing screws, and in order to not block any ventilation holes.
- Provide enough space (>100 mm) on the bottom side of the Daikin HomeHub to connect the Ethernet cable on the bottom side without exceeding its minimum bend radius (typically 90 mm).
- When installing the Daikin HomeHub in a control cabinet or enclosure, make sure there is sufficient clearance in front of the Daikin HomeHub to be able to close the cabinet or enclosure.
- Place the Daikin HomeHub within 2.5 m of a fuse box.



#### INFORMATION

Also read the maximum cable length requirements set out in ["4.2 Overview of electrical connections"](#) [ 14].

## 4.2 Overview of electrical connections

### Connectors

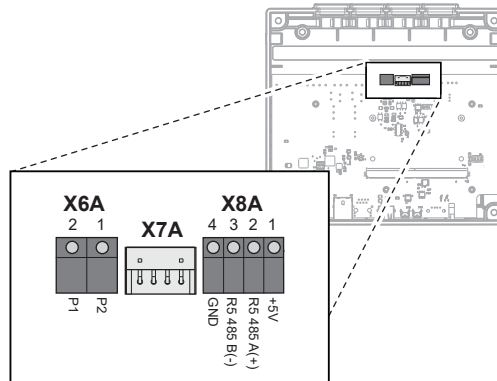

- X6A** To indoor unit (P1/P2 connector)
- X7A** To indoor unit (S21 connector) – NOT supported
- X8A** To Modbus interface (RS-485 connector)

### Connections



#### INFORMATION

**Wiring from the top.** Remove the grommets from the rear casing when connecting the electrical wiring. Before sliding the grommets back into the holes, cut them open with a utility knife, so that you can let the wiring enter the Daikin HomeHub through the grommets. The grommets **MUST** be inserted into the holes before you insert the wiring into the Daikin HomeHub.

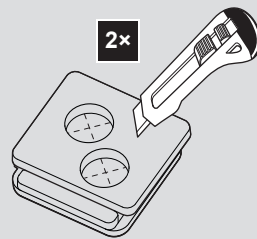

### Indoor unit (P1/P2)

	Connector X6A (screw terminal)
	See the manual or other available documentation of the indoor unit
	Only use harmonised wire providing double insulation suitable for the applicable voltage. Wire size: 0.75–1.25 mm <sup>2</sup> Maximum length: 500 m
	Voltage: 16 V DC — 120 mA

### Modbus Interface (RS-485)

	Connector X8A (screw terminal)
	See the installation manual of the Home Energy Manager (HEM) or Energy Utility Controller



Only use harmonised wire providing double insulation suitable for the applicable voltage.

Wire size: 0.75–1.25 mm<sup>2</sup>

Maximum length: 500 m

# 5 Installation

## 5.1 Precautions when installing the Daikin HomeHub



### **DANGER: RISK OF ELECTROCUTION**

- Turn off the power supply before installing the Daikin HomeHub.
- Do NOT handle the Daikin HomeHub with wet hands.
- Do NOT let the Daikin HomeHub get wet.
- Do NOT disassemble, modify or repair the Daikin HomeHub.
- Turn OFF the power supply in case the Daikin HomeHub gets damaged.

## 5.2 Opening and closing the Daikin HomeHub

### 5.2.1 To open the Daikin HomeHub

- 1** Remove the 2 casing screws on the sides of the Daikin HomeHub with a screwdriver.
- 2** Detach the front casing from the rear casing.

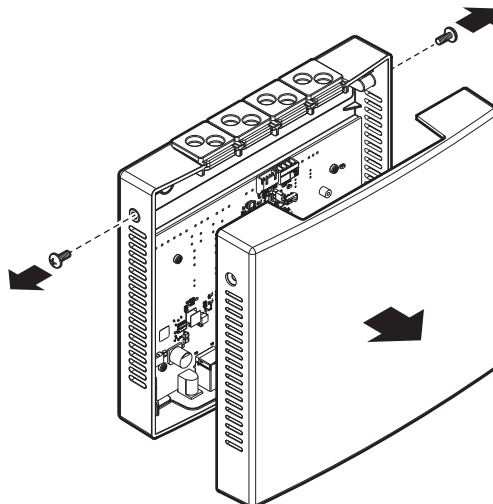

### 5.2.2 To close the Daikin HomeHub

- 1 Attach the front casing to the rear casing.

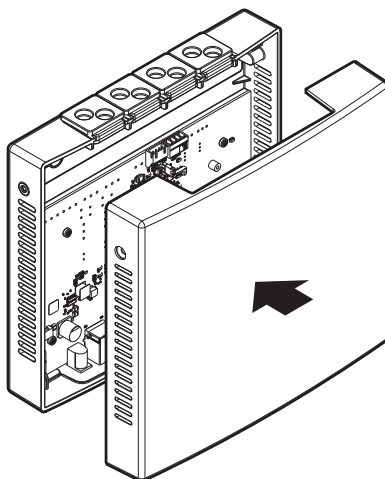

- 2 Gently push or adjust the front casing until it clicks into the rear casing.
- 3 Insert the 2 casing screws in the holes.
- 4 Tighten the screws.

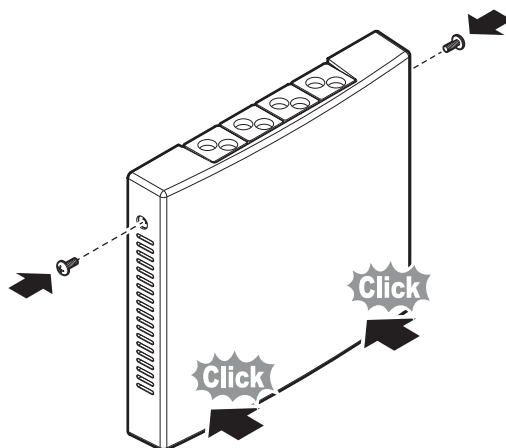

## 5.3 Connecting the electrical wiring



### **DANGER: RISK OF ELECTROCUTION**

Do NOT connect or turn on power supply before you have mounted the Daikin HomeHub, connected the electrical wiring and have closed the Daikin HomeHub.



### **NOTICE**

The wiring for connection is NOT included.

### 5.3.1 To connect the electrical wiring

- 1 Connect the power supply and communication cable(s) to the appropriate terminals. (See following figures per use case.)
- 2 Ensure strain relief by fixing the cables with cable ties (field supply) to the cable tie mountings in the Daikin HomeHub.

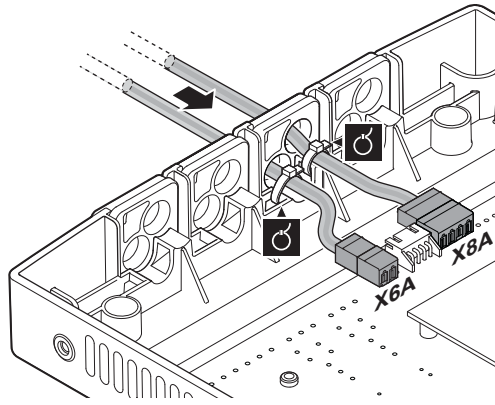

**Use case 1 – PV self-consumption for Daikin Altherma**

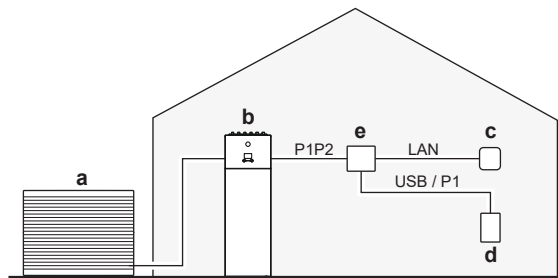

- a** Outdoor unit
- b** Daikin Altherma
- c** Internet router
- d** Current sensor/Digital energy meter
- e** Daikin HomeHub

Connect the EKRHH terminals P1/P2 to the indoor unit terminals P1/P2. If no indoor unit is installed, connect the EKRHH terminals P1/P2 to the outdoor unit terminals P1/P2 or to the Daikin Altherma user interface terminals P1/P2.

**Use case 2 – PV self-consumption for Multi+(DHW)**

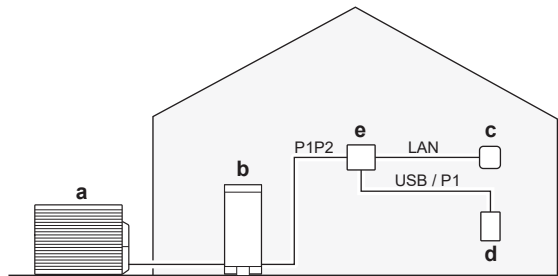

- a** Outdoor unit
- b** Multi+(DHW)
- c** Internet router
- d** Current sensor/Digital energy meter
- e** Daikin HomeHub

Connect the EKRHH terminals P1/P2 to the tank terminals P1/P2. On the Multi+(DHW), use connector X5M.

### Use case 3 – Modbus TCP/IP or RTU for Daikin Altherma

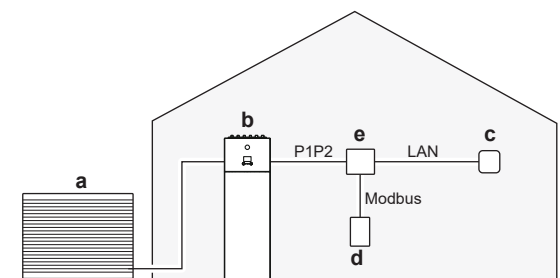

- a Outdoor unit
- b Daikin Altherma
- c Internet router
- d Home Energy Manager (HEM) or Energy Utility Controller
- e Daikin HomeHub

Connect the EKRHH terminals P1/P2 to the indoor unit terminals P1/P2.

### Use case 4 – Modbus TCP/IP or RTU for air-to-air heat pump

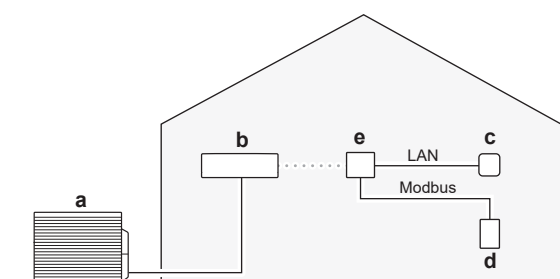

- a Outdoor unit
- b Indoor unit including WLAN adapter (BRP069C4\*)
- c Internet router
- d Home Energy Manager (HEM) or Energy Utility Controller
- e Daikin HomeHub

### Use case- 5 – EEBUS for Daikin Altherma

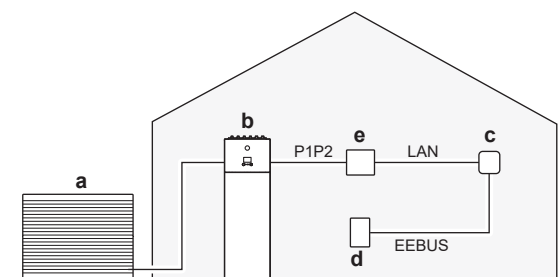

- a Outdoor unit
- b Daikin Altherma
- c Internet router
- d Home Energy Manager (HEM) or grid's Control Box (CB)
- e Daikin HomeHub

Connect the EKRHH terminals P1/P2 to the indoor unit terminals P1/P2. If no indoor unit is installed, connect the EKRHH terminals P1/P2 to the outdoor unit terminals P1/P2 or to the Daikin Altherma user interface terminals P1/P2.

## 5.4 Mounting the Daikin HomeHub

The Daikin HomeHub is mounted to a wall or other flat surface by way of mounting holes in the rear casing. Mounting the Daikin HomeHub to a DIN rail (field supply) is also a possibility.

### 5.4.1 To mount the Daikin HomeHub

#### Mounting to a wall

**Prerequisite:** The front casing of the Daikin HomeHub is removed.

- 1 Determine the mounting location for the Daikin HomeHub. See ["4.1 Installation site requirements"](#) [▶ 13] for more information.
- 2 Drill holes for the plugs and insert the plugs.
- 3 Mount the rear casing to the wall by inserting and tightening the 4 included mounting screws.

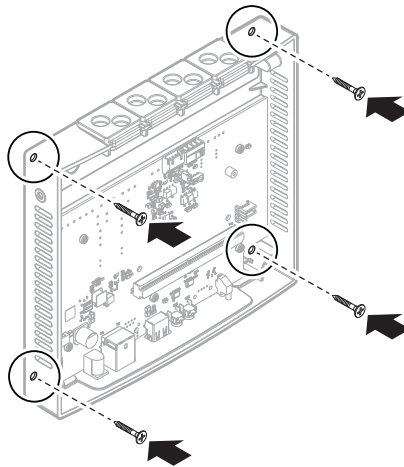

#### Mounting to a DIN rail

**Prerequisite:** The front casing of the Daikin HomeHub is removed.

- 1 Determine the mounting location for the Daikin HomeHub. See ["4.1 Installation site requirements"](#) [▶ 13] for more information.
- 2 Connect the DIN rail clips to the back of the Daikin HomeHub and secure with screws.
- 3 Mount the Daikin HomeHub onto the DIN rail (field supply), using the clips on the back of the Daikin HomeHub to seat it onto the rail and click it into place.

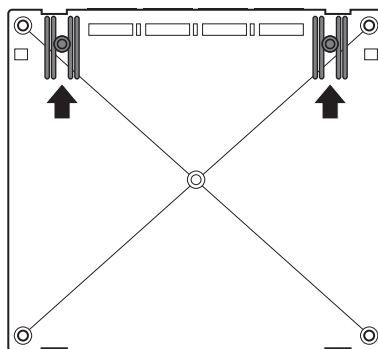

## 6 Application examples



### INFORMATION

It is NOT possible to activate multiple use cases at the same time.

### 6.1 Use case 1 - PV self-consumption for Daikin Altherma

To make efficient use of your solar panels, the Daikin HomeHub can buffer energy into the domestic hot water or rooms when there is an excess of PV energy. For more information, see ["7.2 About PV optimisation"](#) [▶ 28].

For a list of compatible units, see ["2.3 Compatibility"](#) [▶ 7].

An energy sensor is needed for this use case. See ["7.1 Energy sensor"](#) [▶ 26].

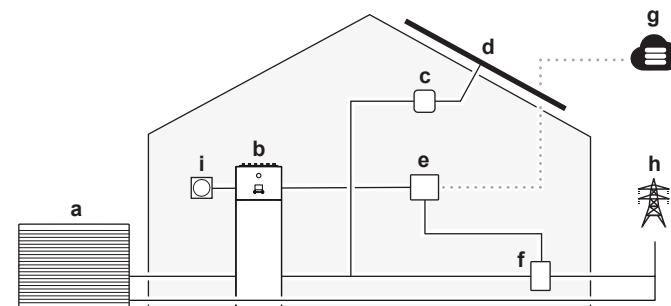

- a** Outdoor unit
- b** Daikin Altherma
- c** Solar inverter
- d** Solar panels
- e** Daikin HomeHub
- f** Digital energy meter or current sensor
- g** ONECTA cloud
- h** Electrical grid
- i** Human Comfort Interface (BRC1\*)

### 6.2 Use case 2 - PV self-consumption for Multi+(DHW)

To make efficient use of your solar panels, the Daikin HomeHub can buffer energy into the domestic hot water without disrupting the cooling of rooms, using the excess of PV energy. For more information, see ["7.2 About PV optimisation"](#) [▶ 28].

For a list of compatible units, see ["2.3 Compatibility"](#) [▶ 7].

An energy sensor is needed for this use case. See ["7.1 Energy sensor"](#) [▶ 26].

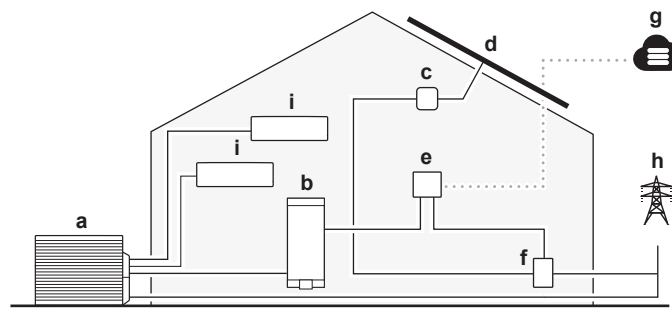

- a Outdoor unit (4MXXM-A)
- b Domestic Hot Water tank (EKHWET-BV3)
- c Solar inverter
- d Solar panels
- e Daikin HomeHub
- f Digital energy meter or current sensor
- g ONECTA cloud
- h Electrical grid
- i Indoor unit

## 6.3 Use case 3 - Modbus TCP/IP or RTU for Daikin Altherma

### 6.3.1 Third-party integrations

This use case makes it possible for a third-party Home Energy Manager (HEM) to communicate with the heat pump. Through the Daikin HomeHub, they can execute a range of commands, for example changing the setpoint of the heat pump. For the full list of possible commands, see ["9.2 Modbus registers"](#) [▶ 39].

This use case is compatible with the Modbus IP and Modbus RTU standards.

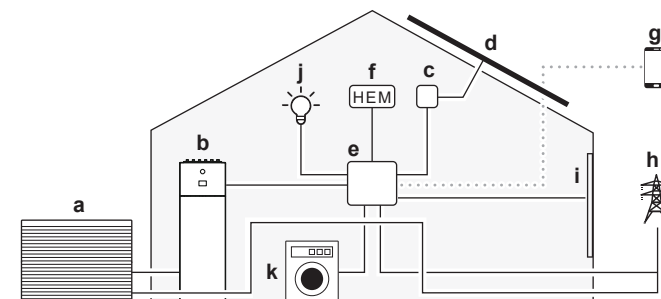

- a Outdoor unit
- b Daikin Altherma
- c Solar inverter
- d Solar panels
- e Daikin HomeHub
- f Home Energy Manager (HEM)
- g Home automation app
- h Electrical grid
- i Smart window blinds
- j Smart lighting
- k Smart white goods



#### INFORMATION

Any power limitation is applied to the whole system. This can affect the system performances.

The functionality of the system CAN also be compromised in case of:

- Power loss of the Daikin HomeHub or rebooting,
- Network communication delays.

### 6.3.2 Smart Grid for utilities

This use case makes it possible for energy utilities to communicate with the heat pump. Through the Daikin HomeHub, they can balance the grid and avoid peaks by enforcing a Smart Grid (SG) operation mode. The SG operation mode adjusts the settings of the heat pump by turning it on/off. In parallel, the power of the heat pump can be adjusted by increasing or decreasing the power limit. For the full list of possible commands, see ["9.2 Modbus registers"](#) [▶ 39].

This use case is compatible with the Modbus IP and Modbus RTU standards.

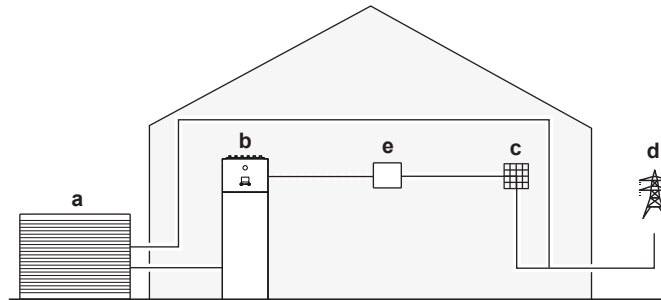

- a Outdoor unit
- b Daikin Altherma
- c Building management or grid controller
- d Electrical grid
- e Daikin HomeHub



#### INFORMATION

Any power limitation is applied to the whole system. This can affect the system performances.

The functionality of the system CAN also be compromised in case of:

- Power loss of the Daikin HomeHub or rebooting,
- Network communication delays.

## 6.4 Use case 4 - Modbus TCP/IP or RTU for air-to-air heat pump

This use case provides Smart Grid (SG) and Demand Control functionality for air-to-air heat pumps. This makes it possible for energy utilities to communicate with air-to-air heat pumps. Through the Daikin HomeHub, they can balance the grid and avoid peaks by enforcing a SG operation mode or providing a Demand Control power limitation value. The SG operation mode adjusts the settings of the air-to-air heat pump by turning it on/off, increasing or decreasing the setpoint, and/or increasing or decreasing the fan speed. The Demand Control power limitation reduces the power consumption of the system. For more information, see ["10.3.1 Smart Grid for air-to-air heat pump"](#) [▶ 50].

This use case is compatible with the Modbus IP and Modbus RTU standards.

Modbus data can be exchanged through Modbus serial using RTU or through Modbus Ethernet layer using TCP protocol.



#### INFORMATION

For this use case, ONLY the Smart Grid operation mode (holding register 1001) and Power limit for Demand Control register (holding register 1002) are supported. See ["10.2.1 Holding registers"](#) [▶ 49].

This use case supports maximum 5 indoor units.

**NOTICE**

The Daikin HomeHub **MUST** always be connected to the internet through LAN.

For a list of compatible units, see "[2.3 Compatibility](#)" [[▶ 7](#)].

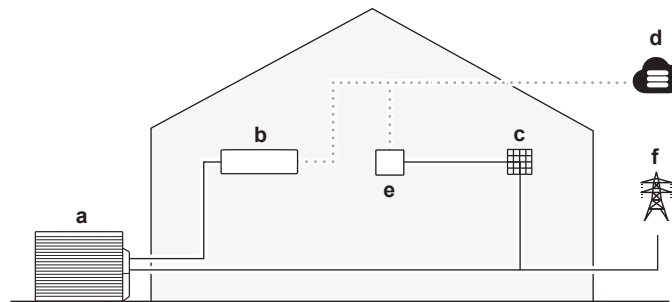

- a** Outdoor unit
- b** Wall-mounted indoor unit including WLAN adapter (BRP069C4\*)
- c** Building management or (third-party) grid controller
- d** ONECTA cloud
- e** Daikin HomeHub
- f** Electrical grid

**INFORMATION**

Any power limitation is applied to the whole system. This can affect the system performances.

The functionality of the system **CAN** also be compromised in case of:

- Power loss of the Daikin HomeHub or rebooting,
- Wi-Fi or internet connectivity loss,
- Network communication delays.

## 6.5 Use case 5 - EEBUS for Daikin Altherma

This use case allows the Daikin heatpump system to be controlled by the Home Energy Manager (HEM) or directly by the grid's Control Box (CB). The Daikin HomeHub supports the following two use cases as defined in the EEBUS standard:

- 1 **Limitation of Power Consumption (LPC):** enables the system to limit the power consumption. This can help to avoid a grid overload.

**INFORMATION**

In general, all LPC requests will be accepted, except if the safety operation is ongoing. In that case the LPC request is declined and the system is free to consume the required power to finish the safety operation. Once the safety operation is completed, the unit will wait for a new LPC request.

- 2 **Monitoring of Power Consumption (MPC):** enables the system to measure the total active power consumption of the connected device. This information can be used by the Home Energy Manager (HEM) as an input to its control algorithm, for power consumption calculations, or for visualisations. The Control Box (CB) can use it to identify hot spots on the grid.

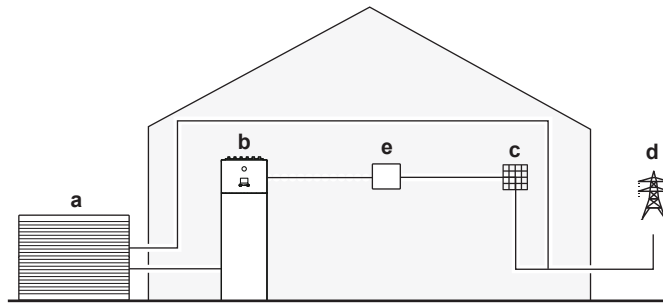

- a Outdoor unit
- b Daikin Altherma
- c Home Energy Manager (HEM) or grid's Control Box (CB)
- d Electrical grid
- e Daikin HomeHub



#### INFORMATION

Any power limitation is applied to the whole system. This can affect the system performances. For more details, please see "[11 Use case 5 - EEBUS for Daikin Altherma](#)" [▶ 53].

# 7 Use case 1 - PV self-consumption for Daikin Altherma

## 7.1 Energy sensor

There are 2 possible ways of measuring the electrical consumption on the circuit:

- With a digital energy meter with P1 port<sup>(1)</sup>, or
- with a current sensor, for single-phase or three-phase (both 3×230 V and 3×400 V+N) installations.



### INFORMATION

The current sensor measures with a precision of 1 W. The Daikin Altherma user interface displays the power values in 0.1 kW steps.

See the following flowchart to check which solution you need:

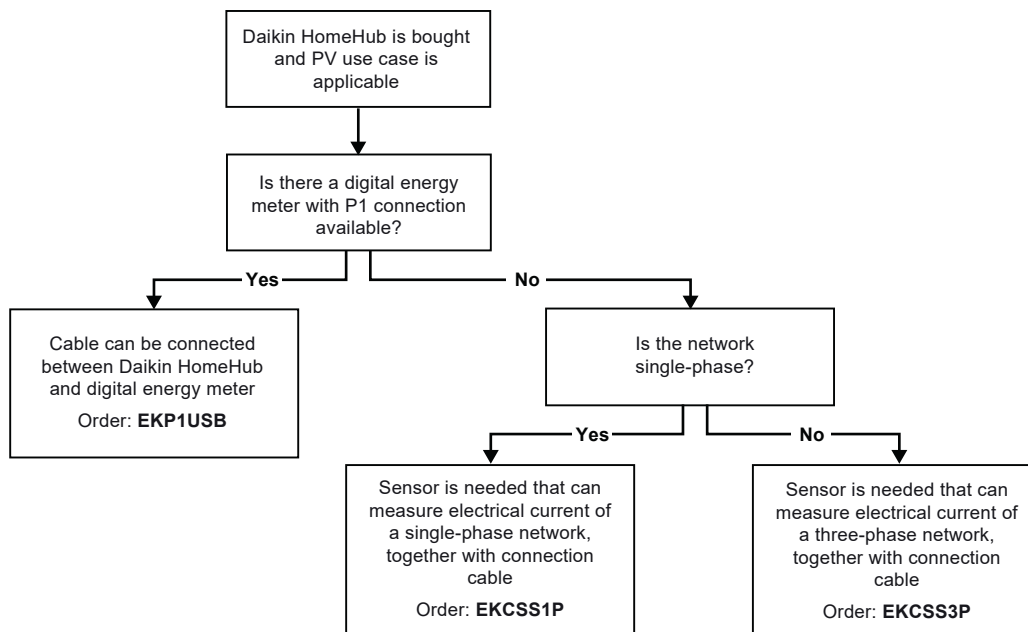

### Connections

The digital energy meter and current sensor can be directly connected to the Daikin HomeHub with a USB/P1 cable.

<sup>(1)</sup> Currently only supported in Belgium. Contact your energy utility company to get detailed information about your digital energy meter.

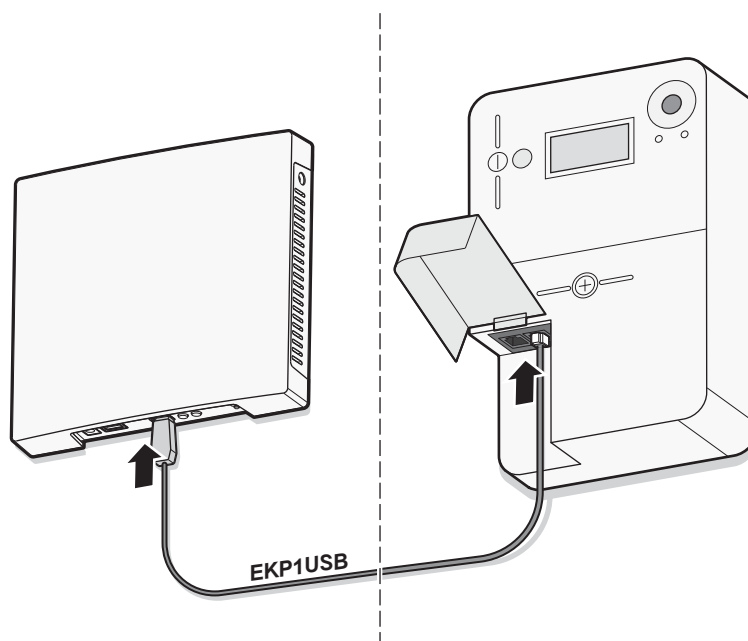
**NOTICE**

When using a digital energy meter, check in the service portal of your energy utility company if the P1 port is activated. If NOT, send a request to your energy utility company to enable power.

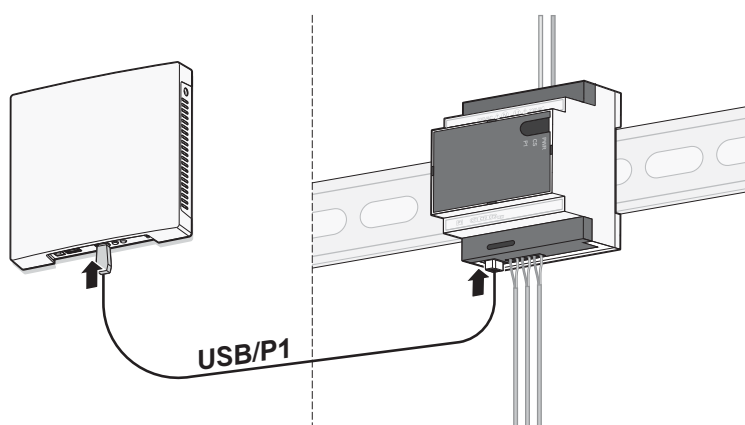
**NOTICE**

To ensure correct power measurement, make sure that the clamps are attached to the correct corresponding phase, depending on the grid configuration. See the installation manual of the current sensor for detailed instructions.

**INFORMATION**

- The maximum installation distance between the Daikin HomeHub and the digital energy meter or current sensor depends on the length of the USB/P1 cable.
- Make sure to install the devices so that the cable reaches both ports.
- Length of the supplied USB/P1 cable is 2.5 m.
- For field supplied USB/P1 cables, correct operation CANNOT be guaranteed.
- The supplied USB/P1 cable is only intended to be used for the functionality of the use case 1 and 2.

## 7.2 About PV optimisation

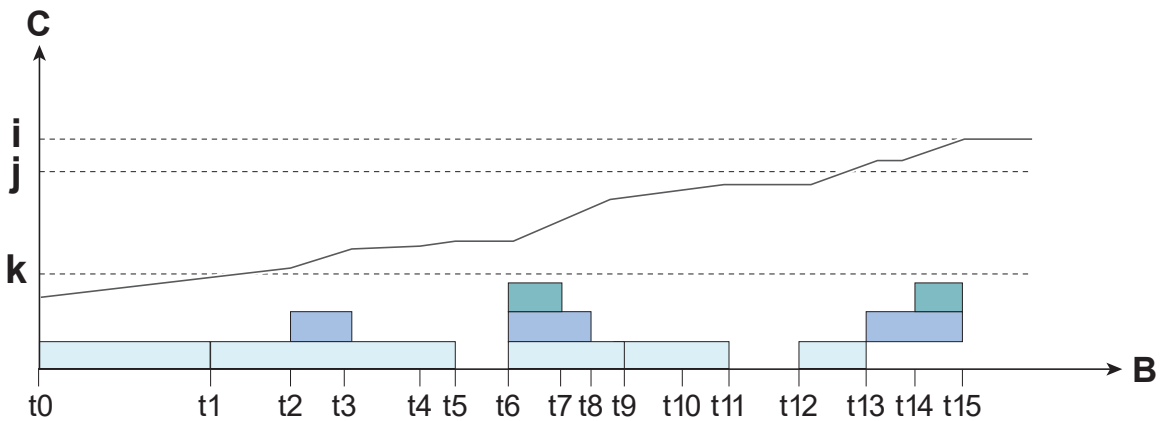
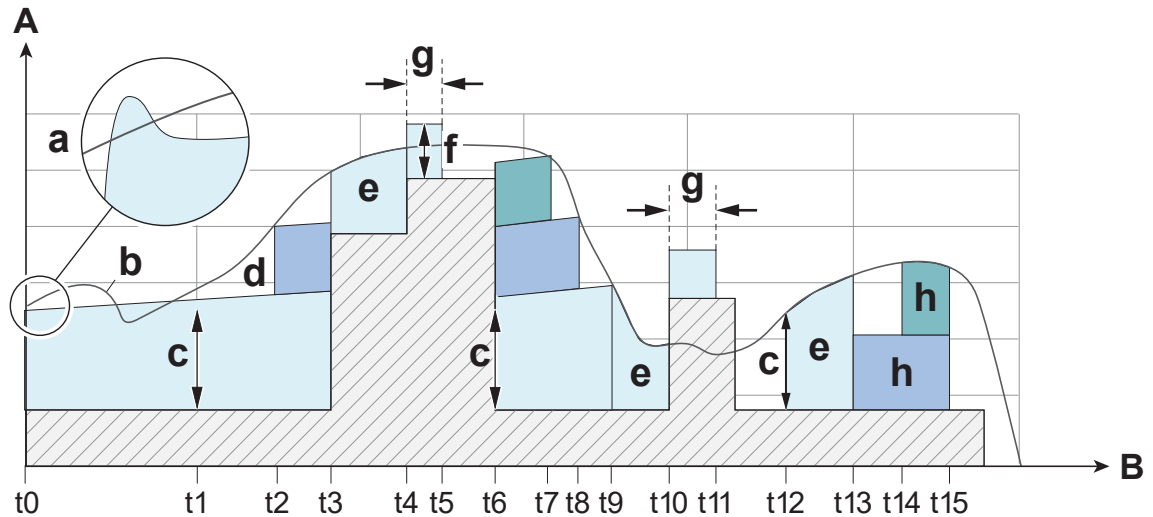

- A** Power
- B** Time
- C** Tank temperature
- Heat pump compressor power
- Heat pump electrical heater step 1 power
- Heat pump electrical heater step 2 power
- Household power (excl. heat pump)
- a** Initial power peak at start-up
- b** PV solar production
- c** Minimum PV power
- d** PV excess power (injected into the grid)
- e** Active limitation of compressor power to match with solar production (0 injection into grid)
- f** Compressor power is held at minimum capacity level (= minimum power at which the compressor can be kept running)
- g** Grace time (5 minutes)
- h** Electrical heater steps, only as compressor limit has been reached
- i** Buffering setpoint
- j** Compressor limit
- k** Normal (eco/comfort) setpoint

The figure above shows an example of the power consumption profile of the unit when buffering solar energy into the tank. For clarity reasons, the power profiles in this example have been simplified. The unit has two electrical heater steps to assist the compressor in heat generation.

The PV solar production has to exceed the house load (household appliances, excluding the heat pump) with a certain amount before buffering can start. This level of PV excess power is defined by the minimum PV power, which can be configured through the Daikin Altherma user interface. The lowest possible value corresponds to the minimum power required for a safe start-up of the compressor.

In this example, the minimum PV power is about 50% higher than the minimum start-up power.

At **time t0**, the tank is cold and the compressor starts up to heat the tank towards the setpoint, showing an initial power peak at start-up (a). It is assumed that the compressor power rises slowly with increasing tank temperature. As long as the normal setpoint is not reached, the unit will not take the PV solar production into account. The compressor power consumption can exceed the PV excess power during its initial start-up and during the displayed dip in PV solar production.

At **time t1**, the tank setpoint is reached and the unit is ready to buffer solar energy into the tank. As the PV excess power exceeds the minimum PV power setting, the compressor continues with tank heating to buffer energy into the tank. The area between the PV solar production curve and the compressor energy area is energy that is still injected into the grid.

At **time t2**, there is enough PV solar production to switch on the first step of the electrical heater. The heater has a constant power consumption.

At **time t3**, the house load increases (for example when a microwave is switched on). The PV excess power is not enough anymore to support both the compressor and electrical heater step 1, so the electrical heater is switched off. Furthermore, the compressor power is actively limited to match with the PV solar production. As such, power injection into the grid is controlled to zero.

At **time t4**, an additional household appliance (for example a hair dryer) is switched on. The PV excess power is not enough anymore to support the compressor, as the PV excess power is lower than the minimum power at which the compressor can still run before switching off (operation at minimum capacity). The algorithm keeps the compressor running at minimum capacity, at the expense of some power being consumed from the grid. If this condition pertains for 5 minutes, the compressor is switched off. The goal of the 5-minute grace period is to prevent frequent on/off behaviour of the compressor when fast fluctuations in PV solar power or house load would occur.

At **time t5**, the grace period expires and the compressor is switched off.

At **time t6**, the microwave and hair dryer are switched off and the house load returns to its base value. There is a large PV excess power (much bigger than the minimum PV power setting) and the compressor and both electrical heater steps are switched on.

At **time t7**, the PV excess power is not enough anymore to support the compressor and the two electrical heater steps. Electrical heater step 2 is switched off.

At **time t8**, the PV excess power has dropped further and the electrical heater step 1 is also switched off.

At **time t9**, the PV excess power has dropped even further and the compressor power is actively limited in order to match it with the PV solar production.

At **time t10**, another household appliance is switched on. There is no PV excess power anymore, power is being consumed from the grid. The algorithm keeps the compressor running at minimum capacity during the grace period.

At **time t11**, the grace period expires and the compressor is switched off.<sup>(1)</sup>

At **time t12**, the PV excess power rises above the minimum PV power level again. The compressor is switched on. The compressor power is actively limited to match with the PV solar production.

<sup>(1)</sup> If tank buffering is interrupted (for example at time t11), it will only resume (for example at time t12) if the tank temperature is below the tank buffering setpoint minus a hysteresis threshold.

At **time t13**, the limit for compressor operation has been reached. The compressor is switched off. The electrical heater step 1 is switched on.

At **time t14**, there is enough PV excess power to also switch on electrical heater step 2.

At **time t15**, the tank temperature reaches the buffering setpoint and tank buffering ends.



### INFORMATION

If the tank temperature exceeds the limit above which the heat pump can operate, the completion of tank buffering relies on the electrical heater(s). If there's not enough PV excess power (for example in winter or on cloudy days) to activate the first electrical heater step, tank buffering cannot be completed. As tank buffering has priority on space buffering, this can lead to space buffering not starting as long as tank buffering is not completed.

On warm and cloudy summer days, there is a risk the tank temperature will drop by a small amount. When the PV excess power frequently drops below the minimum PV power for longer than the grace period and subsequently exceeds the minimum PV power again, the unit will frequently start/stop during buffering. At each start-up, the internal water circuit of the unit (i.e. the plate heat exchanger) needs to heat up again for some time. During this time, slightly colder water flows towards the tank which can cause a small drop in tank temperature.

If between the buffering start/stops the unit switches to space cooling, the drop in tank temperature can be bigger because the internal water circuits (i.e. the plate heat exchanger) will be colder due to the space cooling operation.

### 7.2.1 Schedules

To optimally benefit from the PV optimisation performed by the Daikin HomeHub, while ensuring sufficient availability of domestic hot water, your schedule must be set correctly. By setting your schedule at the end of the day, slightly before you need domestic hot water, you allow the tank to heat up during the day based on solar energy. If there was not enough solar energy available (for example during a cloudy day), the schedule will ensure there is sufficient hot water.

### 7.2.2 Behaviour to safeguard unit reliability

To ensure the reliability of the unit, the PV optimisation logic as explained above can be temporarily overruled. In case the compressor state changes from OFF to ON, the power limit sent to the Daikin Altherma unit will be  $\max(4.5 \text{ kW}, \text{excess PV power in kW})$  for a duration of 15 minutes. This means that the unit will temporarily be allowed to use 4.5 kW even if the excess PV is lower. Once 15 minutes have expired, the normal logic is applied again.

## 7.3 Energy buffering

Depending on user settings, energy buffering either happens in the domestic hot water tank only, or in the domestic hot water tank and in the room. You can choose whether or not to have the electrical heaters assist with the buffering of energy in the domestic hot water tank.

Energy buffering	System requirements	Description
Domestic hot water tank	<ul style="list-style-type: none"> <li>▪ Make sure a domestic hot water tank is part of the system. On the Daikin Altherma user interface, make sure to set field settings:               <ul style="list-style-type: none"> <li>- [E-05]=1</li> <li>- [E-06]=1</li> </ul> </li> <li>▪ Unit control method (Daikin Altherma user interface setting [C-07]): no requirements, but mind the information below.</li> </ul>	The system produces domestic hot water. The tank heats up the water up to the maximum tank temperature, depending on the tank type and set by [6-0E]. If tank buffering is done without electrical heaters, the target temperature is the highest temperature achievable by the heat pump.
Room (heating)	<ul style="list-style-type: none"> <li>▪ Allow for buffering in the room.</li> <li>▪ Unit control method: on the Daikin Altherma user interface, make sure [C-07]=2 (room thermostat control)</li> </ul>	The system heats up the room up to the comfort setpoint. <sup>(a)</sup>
Room (cooling)	<ul style="list-style-type: none"> <li>▪ Allow for buffering in the room.</li> <li>▪ Unit control method: on the Daikin Altherma user interface, make sure [C-07]=2 (room thermostat control)</li> </ul>	The system cools down the room down to the comfort setpoint. <sup>(b)</sup>

<sup>(a)</sup> In case the actual room temperature is below the comfort heating setpoint.

<sup>(b)</sup> In case the actual room temperature is above the comfort cooling setpoint.



### NOTICE

In case of removing the DHW tank from a wall-mounted unit set-up, you **MUST** reinstall the MMI software.



### INFORMATION

Room buffering is **ONLY** possible if the unit control method [C-07]=2 (room thermostat control). This means that if an external room thermostat (Daikin or third party) is configured for the main zone, room buffering is **ONLY** possible in the additional zone.



**INFORMATION**

- The system will ONLY buffer energy when the indoor unit is NOT in normal operation. Normal operation has priority over energy buffering.
- Normal operation CAN be any of the following: **Heating/cooling** (setpoint is not reached), **Domestic hot water** operation (setpoint is not reached during a scheduled operation or a reheat operation), or safety functions (e.g. **Antifrost** or **Disinfection**).
- The space heating/cooling setpoint during room buffering is the buffering setpoint for the room.
- The system will ONLY buffer energy during space heating if the space heating setpoint is lower than the space heating comfort setpoint. The system will ONLY buffer energy during space cooling if the space cooling setpoint is higher than the space cooling comfort setpoint.



**INFORMATION**

**Tank/room buffering priority:**

- The system starts tank buffering first. When tank buffering is at its maximum capacity, then the system switches to room buffering (if enabled).
- Tank buffering can switch to room buffering prior to reaching the maximal capacity because of internal unit logic. In normal operation, the maximum running time for domestic hot water is applicable. See the installer reference guide of the indoor unit for more details.
- When room buffering is ongoing and the tank drops below its maximum capacity (e.g. someone takes a shower), then the system stays at room buffering for a certain amount of time before it switches back to tank buffering.



**INFORMATION**

**Tank buffering:**

- When **Reheat only** or **Reheat + scheduled** is used, the electrical heater can use energy from the grid until the setpoint is reached. If **Schedule only** is used, a cold tank can be the result if the schedule is NOT well set.
- Due to the nature of the system, the tank CAN cool down in some cases because of a too short reheat cycle.



**INFORMATION**

To avoid undesired grid consumption and frequent start/stops of the electrical heater due to variations on the voltage tolerance of the grid, several countermeasures were implemented. As a result, the electrical heater will not be used for space heating, even if this is allowed via the Daikin Altherma user interface.



**INFORMATION**

Because of cloudy weather circumstances or sudden peaks in household consumption, the excess PV power CAN fluctuate. To avoid frequent switching of the unit operation, a grace period is implemented so that buffering will ONLY stop when the excess PV power drops below the threshold for at least 5 minutes. Due to this, the unit CAN temporarily consume energy from the grid to continue buffering.

### 7.3.1 Buffering in case [C-07] = 0 [LWT control]

When, on the Daikin Altherma user interface, [C-07] = 0 (the unit control method is leaving water temperature control), the system is constantly working in normal operation to keep the leaving water at a constant temperature. Energy buffering can only happen in the domestic hot water tank, and only when the system is not in normal operation. This is the case in the following two separate cases:

- Space heating/cooling operation is turned OFF

OR

- During space heating operation:
  - Outdoor temperature > space heating setting [4-02]
  - Room frost protection is not active
- During space cooling operation:
  - Outdoor temperature < space cooling setting [F-01]

# 8 Use case 2 - PV self-consumption for Multi+ (DHW)

## 8.1 Energy sensor

There are 2 possible ways of measuring the electrical consumption on the circuit:

- With a digital energy meter with P1 port<sup>(1)</sup>, or
- with a current sensor, for single-phase or three-phase (both 3×230 V and 3×400 V+N) installations.



### INFORMATION

The current sensor measures with a precision of 1 W. The Daikin Altherma user interface displays the power values in 0.1 kW steps.

See the following flowchart to check which solution you need:

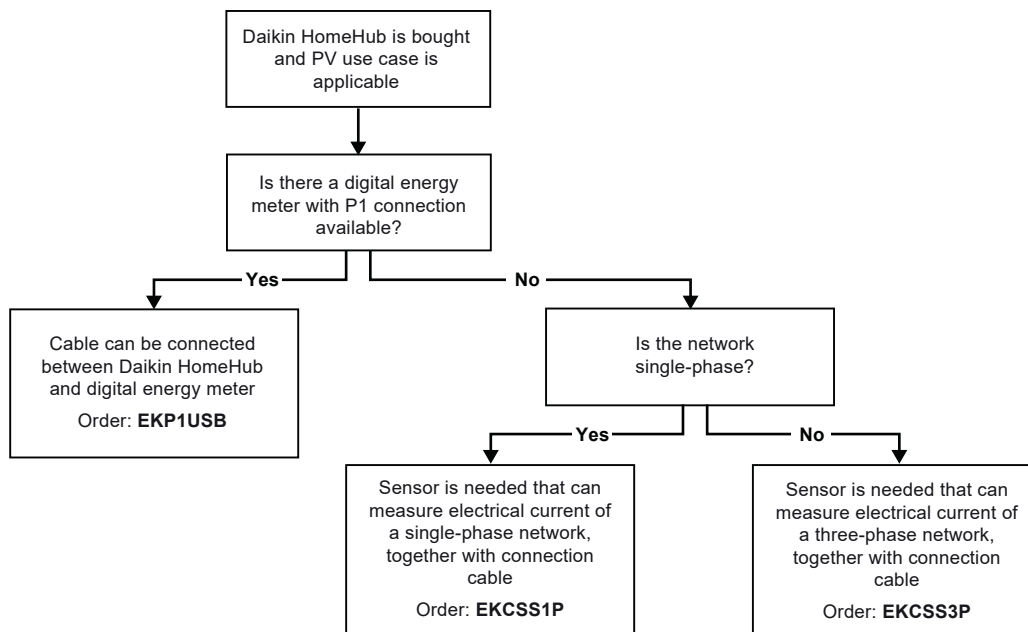

### Connections

The digital energy meter and current sensor can be directly connected to the Daikin HomeHub with a USB/P1 cable.

<sup>(1)</sup> Currently only supported in Belgium. Contact your energy utility company to get detailed information about your digital energy meter.

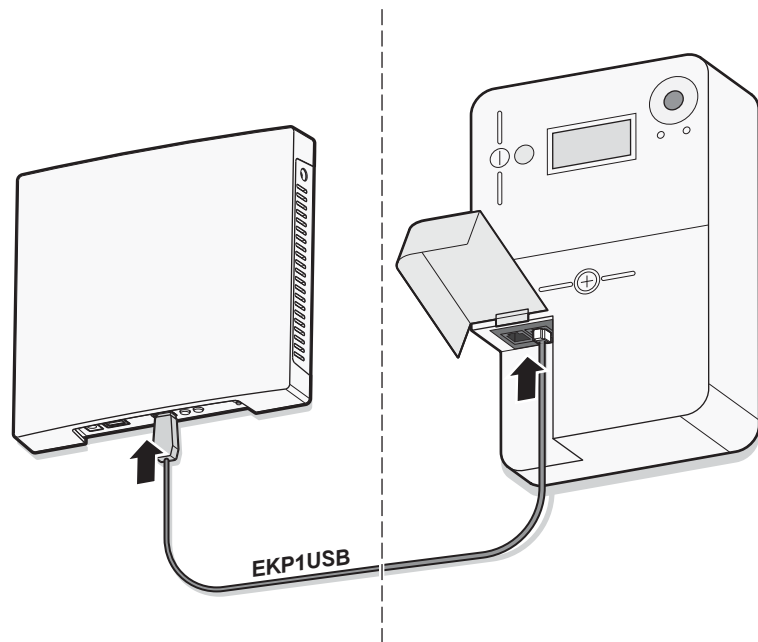

**NOTICE**

When using a digital energy meter, check in the service portal of your energy utility company if the P1 port is activated. If NOT, send a request to your energy utility company to enable power.

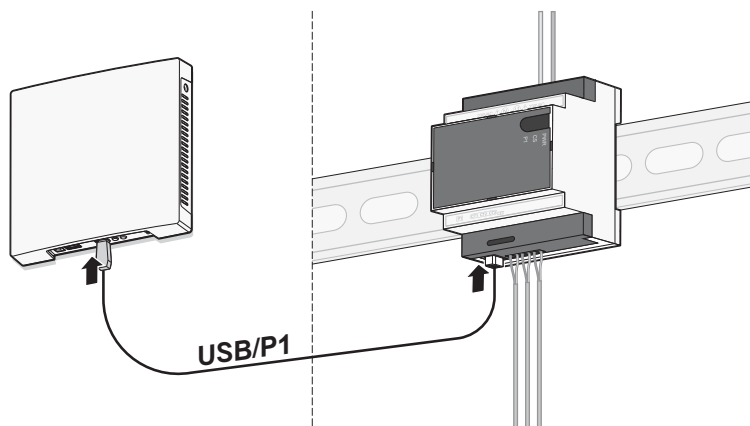

**NOTICE**

To ensure correct power measurement, make sure that the clamps are attached to the correct corresponding phase, depending on the grid configuration. See the installation manual of the current sensor for detailed instructions.



**INFORMATION**

- The maximum installation distance between the Daikin HomeHub and the digital energy meter or current sensor depends on the length of the USB/P1 cable.
- Make sure to install the devices so that the cable reaches both ports.
- Length of the supplied USB/P1 cable is 2.5 m.
- For field supplied USB/P1 cables, correct operation CANNOT be guaranteed.
- The supplied USB/P1 cable is only intended to be used for the functionality of the use case 1 and 2.

## 8.2 About PV optimisation

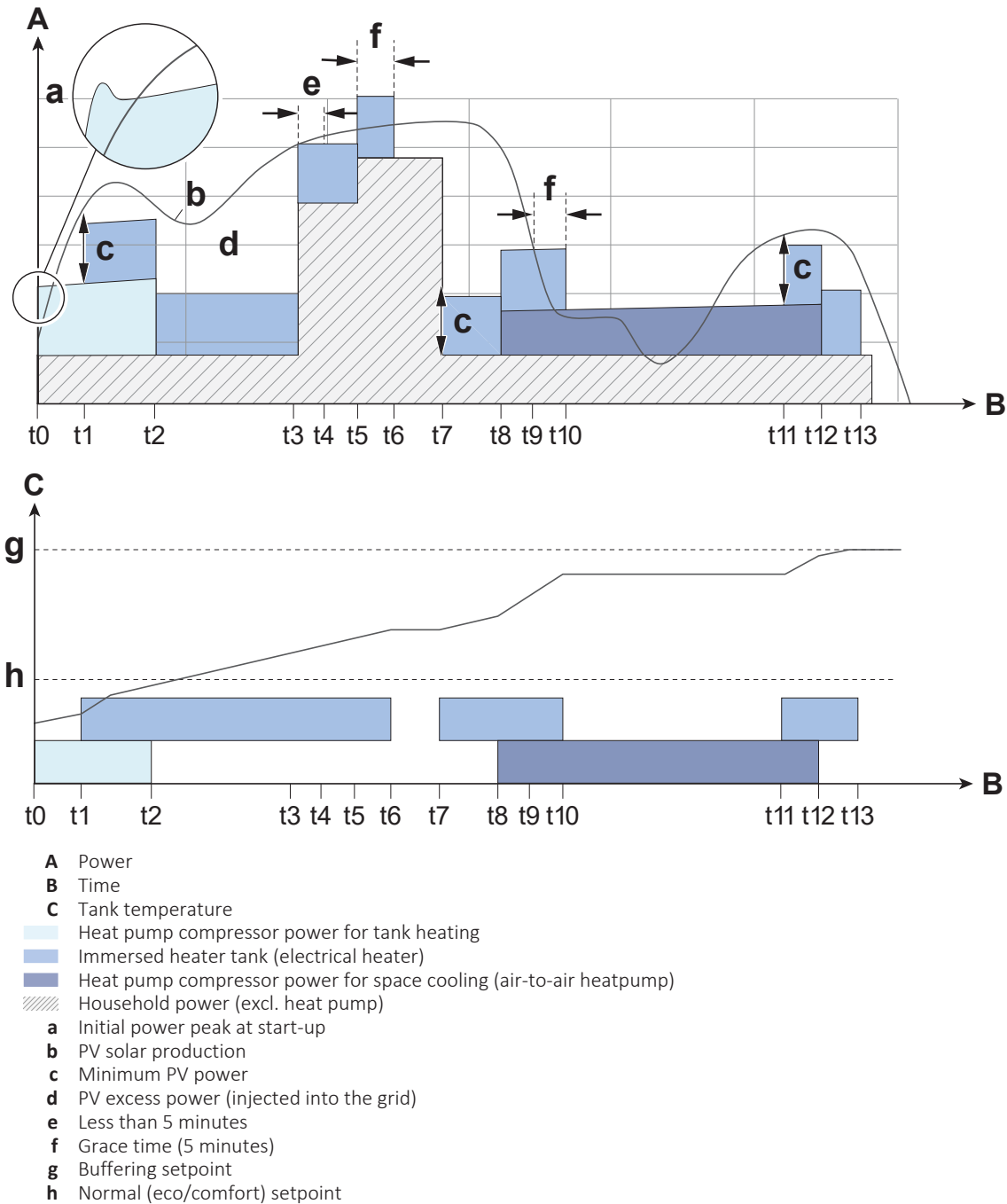

The figure above shows an example of the power consumption profile of the unit when buffering solar energy into the tank. For clarity reasons, the power profiles in this example have been simplified. The unit has an electrical heater to assist the tank heating. The unit has priority for air-to-air heatpump operation (space cooling).

The PV solar production has to exceed the house load (household appliances, including the heat pump) with a certain amount before buffering can start. This level of PV excess power is set to the rated power consumption of the electrical heater, increased with 21% to take a 10% grid voltage increase into account.

**Example:** The threshold of an electrical heater with a rated power consumption of 1.2 kW is set to 1.45 kW.

At **time t0**, the tank temperature is below its setpoint and the compressor is working to heat up the tank towards the setpoint. It is assumed that the compressor power rises slowly with increasing tank temperature.

At **time t1**, the PV excess power equals the minimum PV power setting and the electrical heater is switched on. As such, the electrical heater helps in maximising the self-consumption of available PV excess power. The area between the PV solar production curve and the electrical heater energy area is energy that is still injected into the grid.

At **time t2**, the tank temperature reaches the normal setpoint and the compressor is switched off. As there is still power being injected into the grid, the electrical heater remains on.

At **time t3**, the house load increases (for example when a microwave is switched on). Between t3 and t4, the total consumption exceeds the PV solar production, leading to net power consumption from the grid. As long as this period with grid consumption does not exceed 5 minutes, the algorithm will keep the electrical heater on. The goal of the 5-minute grace period is to prevent frequent on/off behaviour of the electrical heater when fast fluctuations in PV solar power or house load would occur.

At **time t4**, there is enough PV excess power again.

At **time t5**, an additional household appliance (for example a hair dryer) is switched on. The PV excess power is not enough anymore to support the electrical heater. The algorithm keeps the electrical heater on, at the expense of power being consumed from the grid.

At **time t6**, the grace period expires and the electrical heater is switched off.

At **time t7**, the microwave and hair dryer are switched off and the house load returns to its base value. There is a large PV excess power (much bigger than the minimum PV power setting) and the electrical heater is switched on.

At **time t8**, the compressor starts air-to-air heatpump operation (space cooling).

At **time t9**, the PV excess power is not enough anymore to support the electrical heater. The algorithm keeps the electrical heater on, at the expense of some power being consumed from the grid.

At **time t10**, the grace period expires and the electrical heater is switched off. The compressor operation for air-to-air heatpump (space cooling) is not affected (energy buffering of excess PV solar power is only done by the electrical heater).

At **time t11**, the PV excess power equals the minimum PV power setting and the electrical heater is switched on.

At **time t12**, the compressor stops air-to-air heatpump operation (space cooling).

At **time t13**, the tank temperature reached the buffering setpoint and tank buffering ends.

### 8.2.1 Schedules

To optimally benefit from the PV optimisation performed by the Daikin HomeHub, while ensuring sufficient availability of domestic hot water, your schedule must be set correctly. By setting your schedule at the end of the day, slightly before you need domestic hot water, you allow the tank to heat up during the day based on solar energy. If there was not enough solar energy available (for example during a cloudy day), the schedule will ensure there is sufficient hot water.

### 8.3 Energy buffering

Energy buffering happens in the domestic hot water tank only.

Energy buffering	System requirements	Description
Domestic hot water tank	<ul style="list-style-type: none"> <li>Make sure a domestic hot water tank is part of the system. On the Daikin Altherma user interface, make sure to set field settings:                             <ul style="list-style-type: none"> <li>[E-05]=1</li> <li>[E-06]=1</li> </ul> </li> </ul>	The system produces domestic hot water. The tank heats up the water up to the maximum tank temperature, depending on the tank type and set by [6-0E].



**INFORMATION**

Normal operation CAN be either: **Domestic hot water** operation (setpoint is not reached during a scheduled operation or a reheat operation), or safety functions (e.g. **Antifrost** or **Disinfection**).



**INFORMATION**

Energy buffering in the domestic hot water tank will ONLY happen when the excess PV power, which is the difference between the generated solar power and the household power consumption, exceeds the fixed threshold of 1.45 kW (EKHWET tank) or 1.94 kW (CKHWS tank). This value ensures there is enough grid injection to operate the immersed heater and includes a safety margin to allow for 10% grid variation.



**INFORMATION**

Energy buffering in the domestic hot water tank will ONLY happen if the Demand Control feature is disabled in the ONECTA app under the menu items of the connected air-to-air indoor units.



**INFORMATION**

Because of cloudy weather circumstances or sudden peaks in household consumption, the excess PV power CAN fluctuate. To avoid frequent switching of the unit operation, a grace period is implemented so that buffering will ONLY stop when the excess PV power drops below the threshold for at least 5 minutes. Due to this, the unit CAN temporarily consume energy from the grid to continue buffering.

## 9 Use case 3 - Modbus TCP/IP or RTU for Daikin Altherma

### 9.1 Modbus protocol

The following Modbus protocols can be used:

- Modbus RTU
- Modbus TCP/IP

#### Modbus RTU

Parameter	Value
Network	3 wire RS-485
Baud rate	9600
Parity	None
Stop bits	1
Data bits	8
RTU slave address	1~247

#### Modbus TCP/IP

Parameter	Value
Network	Ethernet
Port	<ul style="list-style-type: none"> <li>▪ No encryption: 502</li> <li>▪ TLS encryption: 802</li> </ul>
IP address	IP address of Daikin HomeHub

Modbus configuration can be done via the ONECTA app. See "[13.1.1 ONECTA app settings](#)" [▶ 56].

The Modbus algorithm is change based. This means the unit is only updated if a change in configuration is detected. To prevent changes being lost due to communication outages, it is recommended to periodically refresh the state from client side.

### 9.2 Modbus registers

There are 2 types of registers: holding registers and input registers.

Register type	Access
Holding register	Read/Write
Input register	Read-only

The Daikin HomeHub conforms to the Modbus addressing model. Data model numbering (register offset) is 1-based while PDU addressing is 0-based.

**Example:** To access register 1, you have to use PDU address 0.

The Daikin HomeHub Modbus registers return data in the following formats:

Data type	Signed	Bits	Scaling	Range
Temp16	Signed, two's complement	16	/100	-327.68~327.67°C
Int16			—	-32768~32767
Text16	Unsigned		2 ASCII characters	
Pow16	Signed, two's complement		/100	-327.68~327.67 kW



**INFORMATION**

- Temperature sensor values are returned in Modbus using the Temp16 data format. To convert the value to centigrade, read the Modbus register as a signed 16-bit value and then divide by 100.
- Power values are returned in Modbus using the Pow16 data format. To convert the value to kilowatts (kW), read the Modbus register as a signed 16-bit value and then divide by 100. To write a value in the Modbus register, first multiply your power value in kW with 100.



**INFORMATION**

Unit error codes are returned in Modbus using the Text16 data format. The 16-bit register value MUST be converted to an error code consisting of 2 ASCII characters. Both the high byte value and the low byte value of the 16-bit value represent an ASCII character. Combined, the 2 ASCII characters form the unit error code.

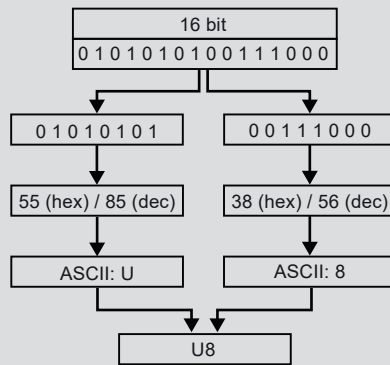

## 9.2.1 Holding registers

Register offset	Name	Type	Range
1	Leaving water Main Heating setpoint	Int16	Depending on field settings
2	Leaving water Main Cooling setpoint		Depending on field settings
3 <sup>(a)</sup>	Operation mode		<ul style="list-style-type: none"> <li>▪ 0: Auto</li> <li>▪ 1: Heating</li> <li>▪ 2: Cooling</li> </ul>
4	Space heating/cooling ON/OFF		<ul style="list-style-type: none"> <li>▪ 0: OFF</li> <li>▪ 1: ON</li> </ul>
6	Room thermostat control Heating setpoint Main		12~30°C
7	Room thermostat control Cooling setpoint Main		15~35°C
9	Quiet mode operation		<ul style="list-style-type: none"> <li>▪ 0: OFF</li> <li>▪ 1: ON</li> </ul>
10	DHW reheat setpoint <sup>(b)</sup>		30~60°C
12	DHW reheat ON/OFF		<ul style="list-style-type: none"> <li>▪ 0: OFF</li> <li>▪ 1: ON</li> </ul>
13	DHW booster mode ON/OFF (Powerful)		<ul style="list-style-type: none"> <li>▪ 0: OFF</li> <li>▪ 1: ON</li> </ul>
53	Weather dependent mode Main		<ul style="list-style-type: none"> <li>▪ 0: Fixed</li> <li>▪ 1: Weather dependent</li> <li>▪ 2: Fixed + scheduled</li> <li>▪ 3: Weather dependent + scheduled</li> </ul>
54	Weather dependent mode Main LWT Heating setpoint offset		-10~10°C
55	Weather dependent mode Main LWT Cooling setpoint offset		-10~10°C
56	Smart Grid operation mode		<ul style="list-style-type: none"> <li>▪ 0: Free running</li> <li>▪ 1: Forced off</li> <li>▪ 2: Recommended on</li> <li>▪ 3: Forced on</li> </ul>
57 <sup>(c)</sup>	Power limit during Recommended on / buffering		Pow16
58 <sup>(c)</sup>	General power limit		0~20 kW

Register offset	Name	Type	Range
59 <sup>(d)</sup>	Thermostat Main Input A <sup>(e)</sup>	Int16	<ul style="list-style-type: none"> <li>▪ 0: OFF</li> <li>▪ 1: ON</li> </ul>
61 <sup>(d)</sup>	Thermostat Add Input A <sup>(e)</sup>		<ul style="list-style-type: none"> <li>▪ 0: OFF</li> <li>▪ 1: ON</li> </ul>
63	Leaving water Add Heating setpoint		Depending on field settings
64	Leaving water Add Cooling setpoint		Depending on field settings
65	Weather dependent mode Add		<ul style="list-style-type: none"> <li>▪ 0: Fixed</li> <li>▪ 1: Weather dependent</li> <li>▪ 2: Fixed + scheduled</li> <li>▪ 3: Weather dependent + scheduled</li> </ul>
66	Weather dependent mode Add LWT Heating setpoint offset		-10~10°C
67	Weather dependent mode Add LWT Cooling setpoint offset		-10~10°C

<sup>(a)</sup> For heating only units, the register will show 32766.

<sup>(b)</sup> The DHW setpoint register is only propagated when the following conditions apply:

- Tank operation is enabled
- Heat pump mode is set to **Reheat only**
- **Setpoint mode** is set to **Fixed**

<sup>(c)</sup> In case the compressor state changes from OFF to ON, the value written in the register can be temporarily overruled to ensure the reliability of the unit. Instead, the limit sent to the Daikin Altherma will be  $\max(4.5 \text{ kW}, \text{register value})$  for a duration of 15 minutes. This means that the unit will temporarily be allowed to use 4.5 kW even if the value written in the register is lower. Once 15 minutes have expired, the values written in the register are restored again.

<sup>(d)</sup> In case the unit control method is set to external room thermostat control ([C-07]=1), this register is only valid when the external thermostat type [C-05] is set to 0:SW Contact. If another external thermostat type is configured, these registers will show 0: OFF.

<sup>(e)</sup> Feature not available on Daikin Altherma 3 R indoor units with Micon ID 20002203, and Daikin Altherma 3 M units with Micon ID 20002203. See "2.3 Compatibility" [▶ 7].



**INFORMATION**

The available range for setpoint registers is determined by the Minimum and Maximum Setpoint of the function defined in the Daikin Altherma system field settings. See the operation manual of the Daikin Altherma for the setpoint ranges.



**INFORMATION**

If a write to a setpoint register is outside of the configured range of the register, the setpoint will be set to the nearest valid minimum or maximum value. For all other registers, if a value outside of the register range is written, then the register value is NOT updated.

9.2.2 Input registers

Register offset	Name	Type	Range
21	Unit abnormality	Int16	<ul style="list-style-type: none"> <li>▪ 0: No error</li> <li>▪ 1: Fault</li> <li>▪ 2: Warning</li> </ul>
22	Unit abnormality code	Text16	2 ASCII characters

Register offset	Name	Type	Range
23	Unit abnormality sub code	Int16	<ul style="list-style-type: none"> <li>If no error: 32766</li> <li>If unit error: 0~99</li> </ul>
30	Circulation pump running		<ul style="list-style-type: none"> <li>0: OFF</li> <li>1: ON</li> </ul>
31	Compressor run		<ul style="list-style-type: none"> <li>0: OFF</li> <li>1: ON</li> </ul>
32	Booster heater run		<ul style="list-style-type: none"> <li>0: OFF</li> <li>1: ON</li> </ul>
33	Disinfection operation		<ul style="list-style-type: none"> <li>0: OFF</li> <li>1: ON</li> </ul>
35	Defrost		<ul style="list-style-type: none"> <li>0: OFF</li> <li>1: ON</li> </ul>
36	Hot Start		<ul style="list-style-type: none"> <li>0: OFF</li> <li>1: ON</li> </ul>
37	3-way valve		<ul style="list-style-type: none"> <li>0: Space heating</li> <li>1: DHW</li> </ul>
38	Operation mode		<ul style="list-style-type: none"> <li>1: Heating</li> <li>2: Cooling</li> </ul>
40	Leaving water temperature PHE		Temp16
41	Leaving water temperature BUH	-100.00~100.00°C	
42	Return water temperature	-100.00~100.00°C	
43	Domestic Hot Water temperature	-100.00~100.00°C	
44	Outside air temperature	-100.00~100.00°C	
45	Liquid refrigerant temperature	-100.00~100.00°C	
49	Flow rate	Int16	Litres/minute×100
50	Remote controller room temperature Main	Temp16	-100.00~100.00°C
51	Heat pump power consumption	Pow16	0~20 kW
52	DHW normal operation	Int16	<ul style="list-style-type: none"> <li>0: Idle/buffering</li> <li>1: Operating</li> </ul>
53	Space heating/cooling normal operation		<ul style="list-style-type: none"> <li>0: Idle/buffering</li> <li>1: Operating</li> </ul>

Register offset	Name	Type	Range
54	Leaving water Main Heating setpoint Lower limit	Temp16	Field setting range
55	Leaving water Main Heating setpoint Upper limit		Field setting range
56	Leaving water Main Cooling setpoint Lower limit		Field setting range
57	Leaving water Main Cooling setpoint Upper limit		Field setting range
58	Leaving water Add Heating setpoint Lower limit		Field setting range
59	Leaving water Add Heating setpoint Upper limit		Field setting range
60	Leaving water Add Cooling setpoint Lower limit		Field setting range
61	Leaving water Add Cooling setpoint Upper limit		Field setting range
76	Domestic Hot Water Upper temperature		-127.00~127.00°C
77	Domestic Hot Water Lower temperature		-127.00~127.00°C
84	Room Heating setpoint Lower limit		Field setting range
85	Room Heating setpoint Upper limit		Field setting range
86	Room Cooling setpoint Lower limit		Field setting range
87	Room Cooling setpoint Upper limit		Field setting range

### 9.2.3 Special return values

In cases when data is not currently available, or a register is not supported in the current Daikin HomeHub configuration, several special return values are assigned. These values will be returned if the Modbus register is read as a signed or unsigned 16 bit value.

Return value	Meaning	Description
32767	Register unsupported	Device does not support requested register.
32766	Register unavailable	Requested register is not available in the current configuration.
32765	Wait for value	Requested register value is not loaded.

If the Daikin HomeHub is timed out or synchronising with the Daikin Altherma master, values will return Wait for value until the value is loaded.

## 9.3 Energy buffering with Smart Grid

The Daikin HomeHub allows a third party (e.g. an energy utility) to set a Smart Grid operation mode. In parallel, the power of the heat pump can be adjusted by increasing or decreasing the power limit. Both actions help to balance the grid and avoid peaks.

There are 4 possible Smart Grid operation mode requests. Depending on Smart Grid operation mode, energy buffering either happens in the domestic hot water only, or in the domestic hot water tank and in the room.

### Free running (normal operation)

There is no interference with the normal operation of the unit, except that the power consumption is limited to the Modbus general power limit (register 58).

### Forced off (blocked operation)

The unit is forced to stop (except during protective functions).

### Forced on

If the unit is operating in normal space heating/cooling or DHW mode, it continues in this mode. If the unit is idle, it is activated to store energy (either in the DHW storage tank or the room). The rate at which the unit consumes energy (both during buffering and normal operation) is limited to the Modbus general power limit (register 58).

Energy buffering	System requirements	Description
Domestic hot water tank	<ul style="list-style-type: none"> <li>▪ Make sure a domestic hot water tank is part of the system. On the Daikin Altherma user interface, make sure to set field settings:               <ul style="list-style-type: none"> <li>- [E-05]=1</li> <li>- [E-06]=1</li> </ul> </li> <li>▪ Unit control method (Daikin Altherma user interface setting [C-07]): no requirements, but mind the information below.</li> </ul>	<p>The system produces domestic hot water. The tank heats up the water up to the maximum tank temperature (depending on the tank type and set by [6-0E]).</p> <p>The electrical heaters will assist with the buffering of energy in the domestic hot water tank.</p>
Room (heating)	Unit control method: on the Daikin Altherma user interface, make sure [C-07]=2 (room thermostat control)	The system heats up the room up to the comfort setpoint. <sup>(a)</sup>
Room (cooling)	Unit control method: on the Daikin Altherma user interface, make sure [C-07]=2 (room thermostat control)	The system cools down the room down to the comfort setpoint. <sup>(b)</sup>

<sup>(a)</sup> In case the actual room temperature is below the comfort heating setpoint.

<sup>(b)</sup> In case the actual room temperature is above the comfort cooling setpoint.

**Recommended on**

If the unit is operating in normal space heating/cooling or DHW mode, it continues in this mode. If the unit is idle, it is activated to store energy. Contrary to **Forced on**, the energy storage during **Recommended on** can be controlled with the allowance flags for room buffering and electrical heaters (see "13.4 Settings for Use case 3" [▶ 61]). The rate at which the unit consumes energy during normal operation is limited to the Modbus general power limit (register 58). During buffering operation, it is limited to the lowest value of the Modbus buffering power limit (register 57) and the Modbus general power limit (register 58).

Energy buffering	System requirements	Description
Domestic hot water tank	<ul style="list-style-type: none"> <li>Make sure a domestic hot water tank is part of the system. On the Daikin Altherma user interface, make sure to set field settings:                             <ul style="list-style-type: none"> <li>[E-05]=1</li> <li>[E-06]=1</li> </ul> </li> <li>Unit control method (Daikin Altherma user interface setting [C-07]): no requirements, but mind the information below.</li> </ul>	The system produces domestic hot water. The tank heats up the water up to the maximum tank temperature, depending on the tank type and set by [6-0E]. If tank buffering is done without electrical heaters, the target temperature is the highest temperature achievable by the heat pump.
Room (heating)	<ul style="list-style-type: none"> <li>Allow for buffering in the room</li> <li>Unit control method: on the Daikin Altherma user interface, make sure [C-07]=2 (room thermostat control)</li> </ul>	The system heats up the room up to the comfort setpoint. <sup>(a)</sup>
Room (cooling)	<ul style="list-style-type: none"> <li>Allow for buffering in the room</li> <li>Unit control method: on the Daikin Altherma user interface, make sure [C-07]=2 (room thermostat control)</li> </ul>	The system cools down the room down to the comfort setpoint. <sup>(b)</sup>

<sup>(a)</sup> In case the actual room temperature is below the comfort heating setpoint.

<sup>(b)</sup> In case the actual room temperature is above the comfort cooling setpoint.



**NOTICE**

In case of removing the DHW tank from a wall-mounted unit set-up, you **MUST** reinstall the MMI software.



**INFORMATION**

Room buffering is **ONLY** possible if the unit control method [C-07]=2 (room thermostat control). This means that if an external room thermostat (Daikin or third party) is configured for the main zone, room buffering is **ONLY** possible in the additional zone.

**INFORMATION**

- The system will **ONLY** buffer energy when the indoor unit is **NOT** in normal operation. Normal operation has priority over energy buffering.
- Normal operation **CAN** be any of the following: **Heating/cooling** (setpoint is not reached), **Domestic hot water** operation (setpoint is not reached during a scheduled operation or a reheat operation), or safety functions (e.g. **Antifrost** or **Disinfection**).
- The space heating/cooling setpoint during room buffering is the buffering setpoint for the room.
- The system will **ONLY** buffer energy during space heating if the space heating setpoint is lower than the space heating comfort setpoint. The system will **ONLY** buffer energy during space cooling if the space cooling setpoint is higher than the space cooling comfort setpoint.

**INFORMATION****Tank/room buffering priority:**

- The system starts tank buffering first. When tank buffering is at its maximum capacity, then the system switches to room buffering (if enabled).
- Tank buffering can switch to room buffering prior to reaching the maximal capacity because of internal unit logic. In normal operation, the maximum running time for domestic hot water is applicable. See the installer reference guide of the indoor unit for more details.
- When room buffering is ongoing and the tank drops below its maximum capacity (e.g. someone takes a shower), then the system stays at room buffering for a certain amount of time before it switches back to tank buffering.

## 9.3.1 Buffering in case [C-07] = 0 [LWT control]

When, on the Daikin Altherma user interface, [C-07] = 0 (the unit control method is leaving water temperature control), the system is constantly working in normal operation to keep the leaving water at a constant temperature. Energy buffering can only happen in the domestic hot water tank, and only when the system is not in normal operation. This is the case in the following two separate cases:

- Space heating/cooling operation is turned OFF

OR

- During space heating operation:
  - Outdoor temperature > space heating setting [4-02]
  - Room frost protection is not active
- During space cooling operation:
  - Outdoor temperature < space cooling setting [F-01]

# 10 Use case 4 - Modbus TCP/IP or RTU for air-to-air heat pump

## 10.1 Modbus protocol

The following Modbus protocols can be used:

- Modbus RTU
- Modbus TCP/IP

### Modbus RTU

Parameter	Value
Network	3 wire RS-485
Baud rate	9600
Parity	None
Stop bits	1
Data bits	8
RTU slave address	1~247

### Modbus TCP/IP

Parameter	Value
Network	Ethernet
Port	<ul style="list-style-type: none"> <li>▪ No encryption: 502</li> <li>▪ TLS encryption: 802</li> </ul>
IP address	IP address of Daikin HomeHub

Modbus configuration can be done via the ONECTA app. See "[13.1.1 ONECTA app settings](#)" [▶ 56].

The Modbus algorithm is change based. This means the unit is only updated if a change in configuration is detected. To prevent changes being lost due to communication outages, it is recommended to periodically refresh the state from client side.

## 10.2 Modbus registers

There are 2 types of registers: holding registers and input registers.

Register type	Access
Holding register	Read/Write
Input register	Read-only

The Daikin HomeHub conforms to the Modbus addressing model. Data model numbering (register offset) is 1-based while PDU addressing is 0-based.

**Example:** To access register 1, you have to use PDU address 0.

The Daikin HomeHub Modbus registers return data in the following formats:

Data type	Signed	Bits	Scaling	Range
Temp16	Signed, two's complement	16	/100	-327.68~327.67°C
Int16			—	-32768~32767
Text16	Unsigned		2 ASCII characters	
Pow16	Signed, two's complement		/100	-327.68~327.67 kW



**INFORMATION**

- Temperature sensor values are returned in Modbus using the Temp16 data format. To convert the value to centigrade, read the Modbus register as a signed 16-bit value and then divide by 100.
- Power values are returned in Modbus using the Pow16 data format. To convert the value to kilowatts (kW), read the Modbus register as a signed 16-bit value and then divide by 100. To write a value in the Modbus register, first multiply your power value in kW with 100.



**INFORMATION**

Unit error codes are returned in Modbus using the Text16 data format. The 16-bit register value MUST be converted to an error code consisting of 2 ASCII characters. Both the high byte value and the low byte value of the 16-bit value represent an ASCII character. Combined, the 2 ASCII characters form the unit error code.

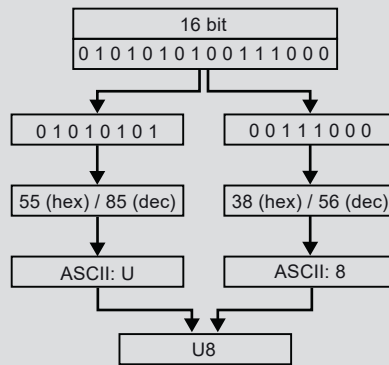

10.2.1 Holding registers

Register offset	Name	Type	Range
1001	Smart Grid operation mode		<ul style="list-style-type: none"> <li>0: Free running</li> <li>1: Forced off</li> <li>2: Recommended on</li> <li>3: Forced on</li> </ul>
1002	Power limit for Demand Control	Pow16	0~20 kW

10.2.2 Special return values

In cases when data is not currently available, or a register is not supported in the current Daikin HomeHub configuration, several special return values are assigned. These values will be returned if the Modbus register is read as a signed or unsigned 16 bit value.

Return value	Meaning	Description
32767	Register unsupported	Device does not support requested register.

Return value	Meaning	Description
32766	Register unavailable	Requested register is not available in the current configuration.
32765	Wait for value	Requested register value is not loaded.

If the Daikin HomeHub is timed out, values will return Wait for value until the value is loaded.

## 10.3 Smart Grid & Demand control

### 10.3.1 Smart Grid for air-to-air heat pump

The Daikin HomeHub allows the air-to-air heat pump installation to receive Smart Grid requests from a third party to control the power consumption of the system. There are 4 possible Smart Grid operation mode requests:

#### **Free running (normal operation)**

There is no Smart Grid intervention. The unit operates normally, respecting any local and scheduled configuration.

At the moment a **Forced off**, **Recommended on** or **Forced on** request is received during **Free running**, the state of the unit is saved. When **Free running** is requested again, the air-to-air heat pump installation restores the saved state from the previous **Free running** operation.

#### **Forced off (blocked operation)**

There is a Smart Grid request to switch the unit OFF. The request aims to stop and prevent any operation of the air-to-air heat pump installation. This request can last maximum 2 hours.

#### **Forced on**

There is a Smart Grid request to increase the power consumption of the air-to-air heat pump installation. This occurs typically when there is an electrical energy excess on the grid.

- The unit is turned ON / stays ON.
- Temperature setpoint is
  - Increased by 2°C if unit operation mode is Heating at the request time,
  - Decreased by 2°C if unit operation mode is Cooling at the request time,
  - Unchanged if the current operation mode is Auto, Dry or Fan at the request time.
- The fan speed mode is unchanged.
  - **Note:** The fan speed mode is set to Auto in case the fan speed mode is not set due to internal unit logic.
- **Note:** The fan speed value is never changed.

#### **Recommended on**

There is a Smart Grid request to increase the power consumption of the air-to-air heat pump installation. This occurs typically when there is an electrical energy excess on the grid.

- The unit is turned ON / stays ON.

- Temperature setpoint is
  - Increased by 1°C if unit operation mode is Heating at the request time,
  - Decreased by 1°C if unit operation mode is Cooling at the request time,
  - Unchanged if the current operation mode is Auto, Dry or Fan at the request time.
- The fan speed mode is
  - Set to Quiet if the unit was OFF when the **Free running** state is left to enter one of the other states,
  - Unchanged if the unit was ON when the **Free running** state is left to enter one of the other states.
- **Note:** The fan speed value is never changed.



#### INFORMATION

The following exceptions apply:

- The **Recommended on** and **Forced on** requests CAN be overruled by a user interaction (any unit configuration, e.g. by remote controller, local schedule, app, ...). If **Free running** operation is again requested, the user settings will be kept instead of restoring the saved state. An exception applies for the cooling and heating setpoints. If they are NOT modified by the user interaction, they are restored to the setting saved during the last **Free running** request to avoid drifting of the setpoints. If one of them is modified by the user interaction, only the other one is restored to the setting saved during the last **Free running**.
- The **Forced off** request CANNOT be overruled by user interactions. When a user attempts to override the **Forced off** operation, the Daikin HomeHub will resend the **Forced off** request. This CAN take up to 2 minutes to take effect.
- When the setpoint increase of the heating setpoint goes beyond the maximum heating setpoint, it is set at the maximum heating setpoint instead. When the setpoint decrease of the cooling setpoint goes beyond the minimum cooling setpoint, it is set at the minimum cooling setpoint instead.

### 10.3.2 Demand control for air-to-air heat pump

In parallel to using the Smart Grid (SG) operation modes (see "[10.3.1 Smart Grid for air-to-air heat pump](#)" [▶ 50]), the power consumption can also be controlled by the Demand control functionality.

When the SG operation mode **Forced off** is active, Demand control is not enabled.

When one of the other SG operation modes is active, the Daikin HomeHub will enable Demand control in manual (fixed) mode. By enabling the Demand control, the maximum power consumption of the outdoor unit can be limited to save energy. Demand control will as such also restrict the capacity of the indoor unit.

The demand capacity (in %) is calculated based on the Demand control power limit written in Modbus holding register 1002 and on the Rated Cooling/Heating capacity of the outdoor unit. The value lies between 40 and 100%. Adjusting the power limit written in the Modbus register thus allows to control the power consumption of the system within this range. The minimum value of 40% ensures enough power is available for safe unit operation.

The demand capacity is individually calculated for each indoor unit (max. 5) controlled by the Daikin HomeHub. All indoor units connected to the same outdoor unit will be limited to the same demand capacity. Indoor units connected to different outdoor units can be subject to a different demand capacity, because of the possible difference of the outdoor unit's Rated Cooling/Heating capacity.

The Demand control settings calculated by the Daikin HomeHub are reflected in the ONECTA app via the Demand control menu of the unit(s) and as such will overrule any previously configured settings.

# 11 Use case 5 - EEBUS for Daikin Altherma

## 11.1 Limitation of Power Consumption (LPC)

### Behaviour in case of the safety operation

In general, all LPC requests will be accepted, except if the safety operation is ongoing. In that case the LPC request is declined and the system is free to consume the required power to finish the safety operation. Once the safety operation is completed, the unit will wait for a new LPC request.

### Behaviour when the compressor is OFF

To ensure the reliability of the unit, a limit of 0 kW will be applied on the unit in case the following two conditions apply:

- The compressor of the heatpump is OFF.
- An LPC request < 4 kW is received.

The unit operation will be stopped as a result, even if there would be a heating/cooling or DHW demand.

### Failsafe operation

When the Daikin HomeHub does not receive any heartbeats from the Home Energy Manager (HEM) or the grid's Control Box (CB) for more than 120 seconds (e.g. when the connection is interrupted), no further communication (LPC request, MPC request, configuration updates) can be received by the Daikin HomeHub. The Daikin HomeHub will enter into a failsafe operation mode. It will limit the power consumption to the configured Failsafe Consumption Active Power Limit for a duration equal to the configured Failsafe Duration Minimum. Both parameters can be configured through the EEBUS protocol.

Parameter	Daikin default value	Possible range
Failsafe Active Consumption Power Limit	20 kW	0~20 kW
Failsafe Duration Minimum	2 h	2~24 h

### Non-controllable operation

When the connection between the Daikin HomeHub and the Daikin Altherma user interface is interrupted (in case the physical connection is broken or the Daikin HomeHub experiences an internal error), the Daikin HomeHub is no longer able to forward LPC requests to the unit. In this scenario, the Daikin Altherma system will safely shut down until the connection is restored.

### Visualisation in the ONECTA app

The ONECTA app will show the limit applied to the system by means of a banner on the home screen.

## 11.2 Monitoring of Power Consumption (MPC)

Monitoring of Power Consumption (MPC) enables the system to measure the total active power consumption of the connected device. This information can be used by the Home Energy Manager (HEM) as an input to its control algorithm, for power

consumption calculations, or for visualisations. The Control Box (CB) can use it to identify hot spots on the grid.

### 11.3 Legal log

The Daikin HomeHub enables to download a log with all operational events of the unit in a Comma-Separated Values (csv) file. You can download the log through the local WebUI (see "[13.6.1 WebUI settings](#)" [▶ 62]) or via the ONECTA app.

Make sure your device is in the same (sub)network as the Daikin HomeHub. Log entries are deleted after 26 months or when the maximum file size of the log is exceeded. The Daikin HomeHub has a mechanism in place to detect and try to correct the corrupted log entries.

Log entries are timestamped and can contain, but are not limited to the following events:

- Change of the LPC state
- Change of the Daikin Altherma power limit or system limit
- Change or (de-)activation of safety operation
- Accepted/Rejected LPC request
- Accepted/Rejected update of the Failsafe Consumption Active Power Limit or the Failsafe Duration Minimum
- Daikin Altherma power consumption logged during a time window of 10 minutes before and 10 minutes after an accepted LPC request.
- Change in the connection status (EEBUS counterparty/Daikin Altherma unit)
- Change in the error state (Daikin HomeHub/Daikin Altherma unit)
- ...

# 12 Firmware updates

The Daikin HomeHub can be automatically updated over the internet to add features, solve security issues, or resolve bugs. To enable automatic updates, you MUST connect the Daikin HomeHub with the router or modem of your internet provider using a LAN cable. The Daikin HomeHub will automatically connect to the internet and receive firmware updates as soon as they become available. The Daikin HomeHub must be powered on to receive updates.

During an automatic update the LEDs will display mode 2 (normal operation). When the update is completed, mode 1 (normal operation) will be displayed again (see "[14.2 LED indication](#)" [▶ 65]).

To assure that an update was successfully installed, check the software version via the online user interface (see "[13.1.2 WebUI settings](#)" [▶ 56]).

# 13 Configuration

Configuration for use cases 1, 2 and 3 happens directly on the user interface of the Daikin Altherma or Multi+(DHW). For more details, see "[13.1.3 Daikin Altherma user interface settings](#)" [▶ 57].

Configuration for use case 4 happens through the ONECTA app. For more details, see "[13.1.1 ONECTA app settings](#)" [▶ 56].

After enabling the Daikin HomeHub on the Daikin Altherma user interface, the configuration for use case 5 happens either through the ONECTA app or through the local WebUI. For more details about user interfaces, see "[13.1 Overview of possible user interfaces](#)" [▶ 56].

## 13.1 Overview of possible user interfaces

### 13.1.1 ONECTA app settings

The following can be done in the ONECTA app:

- Add/remove the Daikin HomeHub to your home,
- Select a use case.
- Change the Modbus settings (use case 4).
- Perform the EEBUS configuration (use case 5).
- Check demand control.

#### EEBUS configuration

Perform the following steps:

- Trust a discovered device.
- Manually add the Subject Key Identifier (SKI) of the device to establish trust.
- Scan the QR code to retrieve the SKI of the Daikin HomeHub.
- Download the legal log file.

#### Modbus settings

Modbus protocol: In general, it is possible to set RTU or TCP/IP (default).

In case of RTU, set the following:

- Modbus node address: 1~247 (default: 1)

In case of TCP/IP protocol, set the following:

- Encryption: none (default) or TLS

### 13.1.2 WebUI settings

An online user interface is available to the user to check the basic EKRHH\* device information, version information, and perform the use case selection. It also enables the EEBUS configuration for the Daikin Altherma use case (see "[11 Use case 5 - EEBUS for Daikin Altherma](#)" [▶ 53]).

The interface can be reached from within the same (sub)network as the EKRHH\* by browsing to <http://yyy:8081> (yyy = the hostname of the EKRHH\*).<sup>(1)</sup>

<sup>(1)</sup> In case you cannot reach the user interface, try to add the suffix "local" to the hostname (<http://yyy.local:8081>).

- The hostname:
  - can be found on the sticker on the back of the Daikin HomeHub.
  - can be constructed based on the serial number without leading zeros (S/N): <http://homehub-524288-S/N>.

**WARNING**

Making the web interface publicly available is the responsibility of the user.

### 13.1.3 Daikin Altherma user interface settings

After connecting the Daikin HomeHub to the Daikin Altherma or Multi+(DHW), you first need to enable the Daikin HomeHub in the Daikin Altherma user interface settings before you can select a use case.

**INFORMATION**

Heating comfort setpoint and Cooling comfort setpoint can ONLY be set if Smart Grid and Room buffering are enabled. You MUST select a use case first before enabling these settings.

Once the Daikin HomeHub is enabled, Smart Grid and Room Buffering settings can be set in the **Daikin HomeHub** menu. No duplication is available elsewhere in the Daikin Altherma user interface settings.

#### To enable the Daikin HomeHub

- 1 Select **Installer settings**.

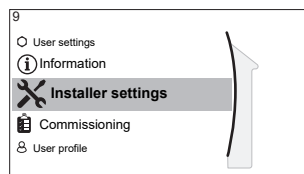

- 2 Select **Daikin HomeHub**.

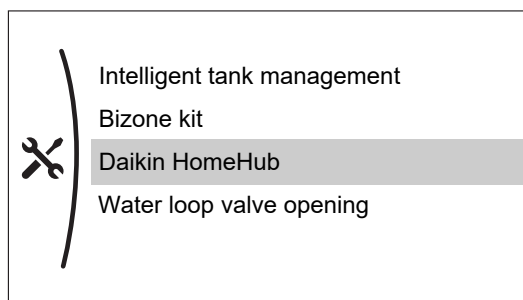

- 3 Select **Add Daikin HomeHub**.

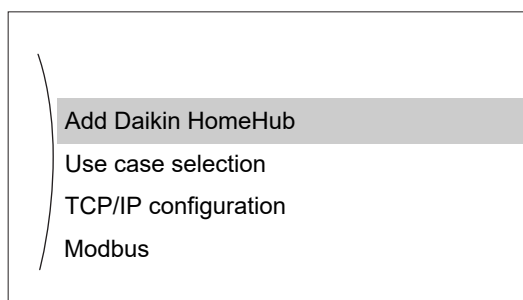

**To select a use case****INFORMATION**

Selection of use case 1 and 2 is done automatically based on the connected unit.

**Note:** There is no visualisation for the use cases on the Daikin Altherma user interface. The homescreen only shows if the Daikin HomeHub is connected or not.

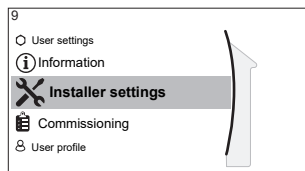
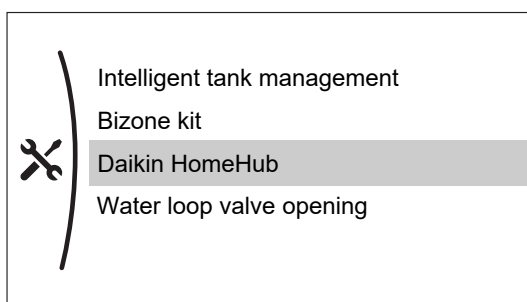
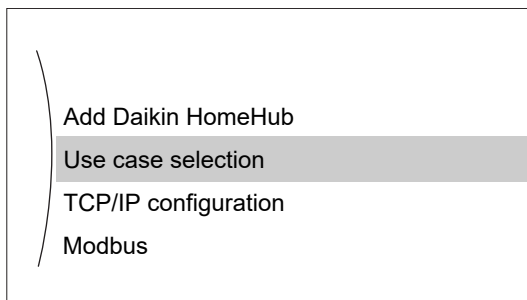
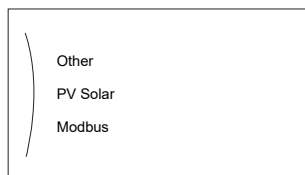
**1 Select Installer settings.****2 Select Daikin HomeHub.****3 Select Use case selection.****4 Select the desired use case.****INFORMATION**

The Daikin Altherma user interface will display **Other** for the use case 4 and 5.

**Field settings for Daikin Altherma or Multi+(DHW) tank**

All field settings are accessible and programmable through the Daikin Altherma user interface:

- Via a specific menu item (see the manual of the Daikin Altherma user interface), and/or
- Via the field settings overview: **Installer settings > Overview field settings**.

Setting	Description	Value <sup>(a)</sup>
[4-08] <sup>(b)</sup>	Power Consumption Control (PCC) – Mode	<ul style="list-style-type: none"> <li>▪ <b>0: No</b></li> <li>▪ 1: Continuous</li> <li>▪ 2: Inputs</li> <li>▪ 3: Current sensor</li> </ul>
[C-07] <sup>(c)</sup>	Unit control	<ul style="list-style-type: none"> <li>▪ 0: Leaving Water Temperature (LWT) control</li> <li>▪ 1: External Room Thermostat (RT) control</li> <li>▪ <b>2: Room Thermostat (RT) control</b></li> </ul>
[E-05] <sup>(c)</sup>	Allow production of DHW	<ul style="list-style-type: none"> <li>▪ <b>0: No</b></li> <li>▪ 1: Yes</li> </ul>
[E-06] <sup>(c)</sup>	Indicates if DHW is supplied by a tank	<ul style="list-style-type: none"> <li>▪ <b>0: No</b></li> <li>▪ 1: Yes</li> </ul>
[6-0E]	Maximum tank temperature	Value range depends on unit type

<sup>(a)</sup> Default value in bold

<sup>(b)</sup> Always set to **0: No** in combination with the Daikin HomeHub.

<sup>(c)</sup> The field settings depend on the selected use case. See "[7.3 Energy buffering](#)" [▶ 31] for more information on which values to set.

## 13.2 Settings for Use case 1

After connecting the Daikin HomeHub, you first need to enable the Daikin HomeHub on the Daikin Altherma user interface. For more details, see "[To enable the Daikin HomeHub](#)" [▶ 57].

Select a use case via the Daikin Altherma user interface (see "[To select a use case](#)" [▶ 58]), the ONECTA app, or the local WebUI.

After you have selected the use case, set the specific settings through the Daikin Altherma user interface.

### 13.2.1 Daikin Altherma user interface settings

After you have selected the **PV Solar** use case, set the following items in the **Installer settings** to the desired value for your situation:

Menu item (Daikin HomeHub > PV Solar)	Value
Minimum PV power	<p>To ensure there is sufficient power available for the unit to remain operational, set the following:</p> <ul style="list-style-type: none"> <li>▪ For units with a smaller capacity: 1 kW~10.0 kW</li> <li>▪ For single-phase outdoor units with a higher capacity: 2 kW~10.0 kW<sup>(a)</sup></li> <li>▪ For three-phase outdoor units with a higher capacity: 2.5 kW~10.0 kW<sup>(a)</sup></li> </ul>

Menu item (Daikin HomeHub > PV Solar)	Value
Allow electrical heaters	<ul style="list-style-type: none"> <li>▪ No</li> <li>▪ Yes</li> </ul>
Enable room buffering	<ul style="list-style-type: none"> <li>▪ No</li> <li>▪ Yes</li> </ul>
Grid configuration <sup>(b)</sup>	Set according to your grid connection: <ul style="list-style-type: none"> <li>▪ None</li> <li>▪ 1x230V</li> <li>▪ 3x230V</li> <li>▪ 3x400V+N</li> </ul>

<sup>(a)</sup> If there is no single-phase or three-phase information available, the range 2.5 kW~10.0 kW is used by default.

<sup>(b)</sup> Default is set to **None**. As long as it is set to **None**, no PV optimisation will happen. Ensure the setting is correct to guarantee a correct readout of power values.

You can also set the **Heating comfort setpoint** and **Cooling comfort setpoint** (Main menu > Room > Room comfort setpoint), but ONLY if [C-07]=2 and room buffering is enabled.



#### INFORMATION

**Heating comfort setpoint** and **Cooling comfort setpoint** can ONLY be set if Smart Grid and Room buffering are enabled. You MUST select a use case first before enabling these settings.

Once the Daikin HomeHub is enabled, Smart Grid and Room Buffering settings can be set in the **Daikin HomeHub** menu. No duplication is available elsewhere in the Daikin Altherma user interface settings.

The excess PV power, which is the difference between the generated solar power and the household power consumption, must exceed the value set by **Minimum PV power** before a buffering operation can start. The value is a compromise between less frequent start/stops of the unit and starting buffering operation at lower injection values.

Make sure to set [4-08] Power Consumption Control to **0: No**. See "[Field settings for Daikin Altherma or Multi+\(DHW\) tank](#)" [▶ 58].

## 13.3 Settings for Use case 2

After connecting the Daikin HomeHub, you first need to enable the Daikin HomeHub on the Daikin Altherma user interface. For more details, see "[To enable the Daikin HomeHub](#)" [▶ 57].

Select a use case via the Daikin Altherma user interface (see "[To select a use case](#)" [▶ 58]), the ONECTA app, or the local WebUI.

After you have selected the use case, set the specific settings through the Daikin Altherma user interface.

### 13.3.1 Daikin Altherma user interface settings

After you have selected a **PV Solar** use case, set the following items in the **Installer settings** to the desired value for your situation:

Menu item (Daikin HomeHub > PV Solar)	Value
Allow electrical heaters	Yes
Enable room buffering	No
Grid configuration <sup>(a)</sup>	Set according to your grid connection: <ul style="list-style-type: none"> <li>▪ None</li> <li>▪ 1x230V</li> <li>▪ 3x230V</li> <li>▪ 3x400V+N</li> </ul>

<sup>(a)</sup> Default is set to **None**. As long as it is set to **None**, no PV optimisation will happen. Ensure the setting is correct to guarantee a correct readout of power values.

Make sure to set [4-08] Power Consumption Control to **0: No**. See "[Field settings for Daikin Altherma or Multi+\(DHW\) tank](#)" [▶ 58].

## 13.4 Settings for Use case 3

After connecting the Daikin HomeHub, you first need to enable the Daikin HomeHub on the Daikin Altherma user interface. For more details, see "[To enable the Daikin HomeHub](#)" [▶ 57].

Select a use case via the Daikin Altherma user interface (see "[To select a use case](#)" [▶ 58]), the ONECTA app, or the local WebUI.

After you have selected the use case, set the specific settings through the Daikin Altherma user interface.

### 13.4.1 Daikin Altherma user interface settings

After you have selected a **Modbus** use case, set the following items in the **Installer settings** to the desired value for your situation:

Menu item (Daikin HomeHub > Modbus)	Value
Connection type	<ul style="list-style-type: none"> <li>▪ In case of RS-485: RTU</li> <li>▪ In case of LAN: TCP/IP</li> </ul>
Smart Grid support	Modbus control
TCP security	<ul style="list-style-type: none"> <li>▪ Not encrypted</li> <li>▪ Encrypted</li> </ul>
Allow electrical heaters	<ul style="list-style-type: none"> <li>▪ No</li> <li>▪ Yes</li> </ul>
Enable room buffering	<ul style="list-style-type: none"> <li>▪ No</li> <li>▪ Yes</li> </ul>

You can also set the **Heating comfort setpoint** and **Cooling comfort setpoint** (Main menu > Room > Room comfort setpoint), but ONLY if [C-07]=2 and room buffering is enabled.

**INFORMATION**

Heating comfort setpoint and Cooling comfort setpoint can ONLY be set if Smart Grid and Room buffering are enabled. You MUST select a use case first before enabling these settings.

Once the Daikin HomeHub is enabled, Smart Grid and Room Buffering settings can be set in the **Daikin HomeHub** menu. No duplication is available elsewhere in the Daikin Altherma user interface settings.

Make sure to set [4-08] Power Consumption Control to **0: No**. See "[Field settings for Daikin Altherma or Multi+\(DHW\) tank](#)" [▶ 58].

## 13.5 Settings for Use case 4

After connecting the Daikin HomeHub, you first need to onboard the Daikin HomeHub in the ONECTA app to be able to configure the settings for this use case.

Select a use case through the ONECTA app or through the local WebUI.

After you have selected the use case, set the specific settings through the ONECTA app.

**INFORMATION**

The Daikin Altherma user interface will display **Other** for the use case 4 and 5.

## 13.6 Settings for Use case 5

After connecting the Daikin HomeHub to the Daikin Altherma, you first need to enable the Daikin HomeHub on the Daikin Altherma user interface. For more details, see "[To enable the Daikin HomeHub](#)" [▶ 57].

Once you have enabled the Daikin HomeHub on the Daikin Altherma user interface, you can proceed with the configuration either through the ONECTA app or through the local WebUI.

Specific settings can be set either through the local WebUI or through the ONECTA app.

**INFORMATION**

The Daikin Altherma user interface will display **Other** for the use case 4 and 5.

**NOTICE**

To be able to activate and correctly use the EEBUS use case, either via the ONECTA app or via the local WebUI, it is required that the EKRHH\* is connected:

- to the unit via P1/P2, and
- to the internet.

### 13.6.1 WebUI settings

For more details about how to reach the interface, see "[13.1.2 WebUI settings](#)" [▶ 56].

After browsing to the local WebUI, you need to select the EEBUS use case and start the pairing process between the Home Energy Manager (HEM) or grid's Control Box (CB). Both parties need to establish trust to enable the EEBUS connection. To

do this, the Daikin HomeHub needs to trust the Home Energy Manager (HEM) or grid's Control Box (CB).

- Under "**Use Case Selection**" (a) > "**Active use case**" (b) select EEBUS from the dropdown menu and click on "**Save changes**" (c).

#### (a) Use Case Selection

#### (b) Active use case

EEBUS

(c) Save changes



#### INFORMATION

It will take up to 1 minute to activate and start-up this use case.

- Refresh the page. There are now two options to start a pairing process:
  - Look for the Home Energy Manager (HEM) or grid's Control Box (CB) under "**Other devices**" (a) and click on "**Trust**" (b). When establishing trust was successful, the device will now appear under "**My Devices**" (c).

#### Other Devices (a)

Brand	Type	Model	(b) Trust
Daikin SKI	Altherma	Altherma	
4E0EE2C98DA2A3629938B98F7ACD4D20E912F3B8			

#### My Devices (c)

Brand	Type	Model	Connected	
Daikin SKI	Altherma	Altherma	No	x
4E0EE2C98DA2A3629938B98F7ACD4D20E912F3B8				

- Manually add the SKI of the Home Energy Manager (HEM) or grid's Control Box (CB) under "**Trust a device**". To retrieve the SKI, you can scan the QR code provided by the Home Energy Manager (HEM) or grid's Control Box (CB).

#### Trust a device

SKI

Trust



**INFORMATION**

The Home Energy Manager (HEM) or grid's Control Box (CB) will also need to establish trust with the Daikin HomeHub to enable the EEBUS connection. This can happen at any time, but only after the EEBUS use case has been selected. The information required from the EKRHH\* to do so is contained in the QR code visualised in the WebUI. In case no QR code is shown, the activation of the EEBUS use case was not successful.

# 14 Troubleshooting

## 14.1 Buttons

Operation	Button	Action	Description
Reset	PB1	Short push	Software reset, no reboot
Restart		Press 10 seconds	Reboots the system
Factory reset	PB1+PB2	<ul style="list-style-type: none"> <li>▪ Push both buttons.</li> <li>▪ While pressing and holding both buttons, power off and on the device.</li> <li>▪ Hold the buttons for about 10 seconds.</li> </ul>	Restores the device to its original out-of-factory state

## 14.2 LED indication

### Daikin HomeHub

The Daikin HomeHub has 2 LEDs that display information.

LED	Colour	Description
LED1	Green	Status LED 1
LED2	Blue	Status LED 2

### Normal operation

Mode	Status	Description
0	<ul style="list-style-type: none"> <li>▪ LED1 (green): OFF</li> <li>▪ LED2 (blue): OFF</li> </ul>	Power off
1	<ul style="list-style-type: none"> <li>▪ LED1 (green): OFF</li> <li>▪ LED2 (blue): Heart beat<sup>(a)</sup></li> </ul>	Operating system running
2	<ul style="list-style-type: none"> <li>▪ LED1 (green): Blinking (5 s interval)</li> <li>▪ LED2 (blue): OFF</li> </ul>	Device updating

<sup>(a)</sup> Variable rate depending on system load

### Troubleshooting states

Mode	Status	Description
0	<ul style="list-style-type: none"> <li>▪ LED1 (green): ON</li> <li>▪ LED2 (blue): OFF</li> </ul>	System boot loading error
1	<ul style="list-style-type: none"> <li>▪ LED1 (green): OFF</li> <li>▪ LED2 (blue): ON</li> </ul>	Linux boot error

Mode	Status	Description
2	<ul style="list-style-type: none"> <li>▪ LED1 (green): ON</li> <li>▪ LED2 (blue): OFF</li> </ul>	Power on – not booted
3	<ul style="list-style-type: none"> <li>▪ LED1 (green): OFF</li> <li>▪ LED2 (blue): ON</li> </ul>	Bootloader loading
4	<ul style="list-style-type: none"> <li>▪ LED1 (green): ON</li> <li>▪ LED2 (blue): Heart beat<sup>(a)</sup></li> </ul>	Operating system / Application loading
5	<ul style="list-style-type: none"> <li>▪ LED1 (green): Blinking (0.2 s interval)</li> <li>▪ LED2 (blue): Heart beat<sup>(a)</sup></li> </ul>	PB1 pushed
6	<ul style="list-style-type: none"> <li>▪ LED1 (green): Blinking (1 s interval)</li> <li>▪ LED2 (blue): Heart beat<sup>(a)</sup></li> </ul>	PB2 pushed

<sup>(a)</sup> Variable rate depending on system load

### Current sensor

The current sensor has 3 LEDs that display information.

#### Normal operation

LED	Colour	Status	Description
PWR	Yellow	OFF	CSP1 device is not powered
		ON	CSP1 device is powered
CS	Green	OFF	No current measured or no current sensor connected
		Blinking (1 second interval)	Cumulated measured current <50 A. The value determines how long the LED is on: 20 msec per cumulated current in ampere.
		ON	Cumulated measured current $\geq 50$ A
P1	Red	OFF	USB/P1 cable not connected or no communication
		Blinking	USB/P1 cable not connected or no communication
		ON	Daikin HomeHub is receiving data through USB/P1 connection

If after installation, the PWR LED does not light up, check the connection with the mains power if you use a power adapter.

#### Troubleshooting states

LED	Status	Solution
PWR	OFF	Check power connections
CS		If power is used, check the clamp connection
P1		Check the USB/P1 cable connection to the Daikin HomeHub

## 14.3 Daikin Altherma user interface indications

Correct mounting and wiring of the clamps to the current sensor can be validated through the user interface of the Daikin Altherma or Multi+(DHW) to which the Daikin HomeHub is connected.

A correct or incorrect P1/P2 connection between the Daikin HomeHub and Daikin Altherma or Multi+(DHW) is indicated on the homescreen (a):

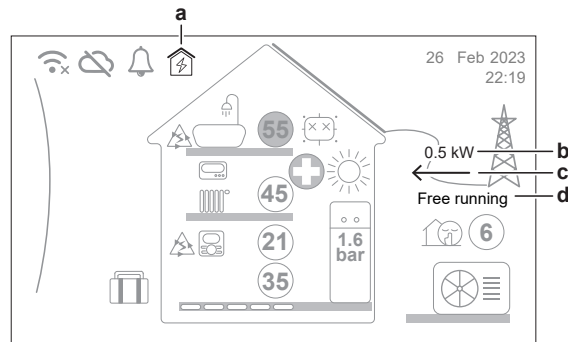

<b>a</b>	Daikin HomeHub connection: <ul style="list-style-type: none"> <li>▪ : Connected</li> <li>▪ : NOT connected</li> <li>▪ : Error (U8-18~20. See "14.4 Error codes: Overview" [▶ 67])</li> </ul>
<b>b</b>	Power flow – value (displayed as 0.1 kW steps)
<b>c</b>	Power flow – direction: <ul style="list-style-type: none"> <li>▪ : Injected into the grid</li> <li>▪ : Taken from the grid</li> </ul>
<b>d</b>	Smart Grid operation mode: <ul style="list-style-type: none"> <li>▪ Free running</li> <li>▪ Forced off</li> <li>▪ Recommended on</li> <li>▪ Forced on</li> </ul>

If the sun isn't shining and the consumption of the house is rather high (for example when the oven is switched on), the power flow (c) should always be taken from the grid (pointing to the left). If this is not the case, the mounting or wiring of the clamps is probably not correct.

## 14.4 Error codes: Overview

Code	Description	Solution
U8-15	Connection with the Daikin HomeHub lost <sup>(a)</sup>	<ul style="list-style-type: none"> <li>▪ Reset and/or reboot</li> <li>▪ Reconnect/replace P1/P2 cable</li> <li>▪ Make sure there are not 2 Daikin HomeHub on the same P1/P2</li> <li>▪ See the manual of the indoor unit</li> </ul>

Code	Description	Solution
U8-18	Daikin HomeHub internal error	<ul style="list-style-type: none"> <li>▪ Reset and/or reboot</li> <li>▪ Factory reset</li> <li>▪ Check Ethernet cable</li> <li>▪ Check RTU/TCP mode</li> <li>▪ Check TCP mode (static or DHCP)</li> <li>▪ Check IP address &amp; port</li> <li>▪ Check if TLS encryption is set properly</li> </ul>
U8-19	Daikin HomeHub PV Solar Smart sensor error	<ul style="list-style-type: none"> <li>▪ Reset and/or reboot</li> <li>▪ Reconnect/replace USB/P1 cable</li> <li>▪ Check the troubleshooting options of the current sensor (see "Current sensor" [▶ 66])</li> </ul>
U8-20	Daikin HomeHub modbus error	<ul style="list-style-type: none"> <li>▪ Reset and/or reboot</li> <li>▪ Check Ethernet cable</li> <li>▪ Check RTU/TCP mode</li> <li>▪ Check TCP mode (static or DHCP)</li> <li>▪ Check IP address &amp; port</li> <li>▪ Check if TLS encryption is set properly</li> </ul>

<sup>(a)</sup> It can take up to 3 minutes to restore connection with the Daikin HomeHub.

## 14.5 Behaviour during a connection loss

### Use case 1, 2 and 3

When the connection between the Daikin HomeHub and the Daikin Altherma system is lost, the Daikin Altherma user interface will show the U8-15 error. The system will then restore its default settings as if the Daikin HomeHub was not connected.

#### Result:

- All requests from the heatpump and the electrical heater will be reset for both the DHW and heating/cooling operation.
- The requested power limit will be reset to 20 kW.

### Use case 4

When the internet connection to the cloud is interrupted, the indoor unit cannot receive any new command and will continue in its last known operation. This operation can be changed by using the remote controller.

When the Modbus connection to the Daikin HomeHub is interrupted, no new input is received by the Daikin HomeHub. The indoor unit will continue in its last known operation. The **Forced off** smart grid operation will be terminated once the 2 h limit expires.

### Use case 5

When the connection between the Daikin HomeHub and the Daikin Altherma is lost (the Daikin Altherma user interface will show the U8-15 error) and/or the Daikin HomeHub experiences an internal error (the Daikin Altherma user interface

will show the U8-18 error), the system will go into a so-called non-controllable state. To ensure compliance with the §14a regulation, even at times when it is not possible to actively control the power consumption of the Daikin Altherma, the Daikin Altherma unit will set the power limit to 0 kW and thus, switch off entirely.

## 15 Hand-over to the user

After having installed and configured the Daikin HomeHub, hand over this installation manual to the user and make him/her aware of the safety precautions.

# 16 Glossary

**BUH = Backup heater**

The backup heater provides extra heating capacity in addition to the heat pump.

**CB = Control Box**

A device that manages and safeguards electrical devices.

**DHW = Domestic hot water**

Hot water used, in any type of building, for domestic purposes.

**DIN rail**

A standardised metal rail used for mounting electrical and industrial control equipment.

**HEM = Home energy management**

A home energy management system is a system of computer-aided tools to monitor, control and optimise the performance of your energy production, storage and consumption at home.

**HTTP = Hypertext Transfer Protocol**

A protocol used to access and exchange data over a network.

**IGMP = Internet Group Management Protocol**

A protocol that allows a group of several devices to share one IP address and receive the same data.

**LAN = Local Area Network**

A network that connects computers and devices within a limited geographical area.

**LPC = Limitation of Power Consumption**

A practice of controlling the amount of used power.

**LWT = Leaving water temperature**

Water temperature at the water outlet of the unit.

**mDNS = Multicast Domain Name System**

A protocol that allows users to connect to different devices in an easier way.

**MPC = Monitoring of Power Consumption**

A practice of monitoring the energy consumption.

**PDU = Protocol data unit**

A single unit of information transmitted among peer entities of a computer network. It can contain control information, address information or data.

**PHE = Plate heat exchanger**

A type of heat exchanger that uses metal plates to transfer heat between 2 fluids.

**PV energy = Photovoltaic energy**

Energy generated by photovoltaic (solar) panels. A photovoltaic system converts sunlight into electricity.

**RTU = Remote Terminal Unit**

A microprocessor-based remote device that monitors and controls devices in the field.

Modbus RTU is a compact, binary version of the Modbus protocol designed for communication over serial lines such as RS-485.

**SG = Smart Grid**

An electricity network to monitor the flow of energy in real time.

**SKI = Subject Key Identifier**

Provides a unique identifier that contains a particular public key.

**SW = Software**

A set of instructions designed to perform specific tasks on a computer.

**TCP/IP = Transmission Control Protocol/Internet Protocol**

A set of protocols that allows data transmission over networks.

Modbus TCP/IP is a variant of the Modbus protocol that uses TCP/IP to communicate over Ethernet networks.

**TLS = Transport Layer Security**

A protocol that ensures privacy, integrity and authenticity of data exchanged between applications over a network.

